

T-1000



(844) 477-4911 | www.ipsiscan.com

Advanced Poly-Bagger™

(Model T-1000-S14)



Operation Manual, Version 9 Revision G

 **Advanced
Poly-Packaging, Inc.**

1331 Emmitt Road • Akron, OH 44306 • 1-800-754-4403 • fax 330-785-4010 • www.advancedpoly.com

Acknowledgments

Written By: David Kolinski-Schultz

Reviewed By: Stuart Baker

Copyright

Nov 2018 (Ver 9G) Apr 2018 (Ver. 9F) Jan 2018 (Ver. 9E) Nov 2017 (Ver. 9D), 2014 (Ver. 8), 2010 (Ver. 7) 2009 (Ver. 6), 2007 (Ver. 5), 2006 (Ver. 4), 2003 (Ver. 3), 2001 (Ver. 2), 1995 (Ver. 1), Advanced Poly-Packaging, Inc. (APPI). All rights reserved.

This manual and the program operating the equipment described in it are copyrighted. You may not copy this manual in whole or part without the consent of Advanced Poly-Packaging, Inc.

All information pertaining to the promotion, sale, distribution, operation and maintenance of the T-1000-S14 ADVANCED POLY-BAGGER including this manual, drawings, schematic, wiring diagrams, VHS video tapes, brochures, specification sheets, figures, charts, or any other information, due to its proprietary design and manufacture remain the property of Advanced Poly Packaging, Inc. Unauthorized duplication, distribution or disclosure to third parties without the express permission of Advanced Poly-Packaging, Inc. is strictly prohibited.

Trademarks

T-1000-S14 is a trademark of Advanced Poly-Packaging, Inc. Advanced Poly-Packaging, Inc. owns also the following trademarks: Advanced Poly-Bags, Advanced Poly-Bagger, Seal-a-Print, Roll-a-Print, Twin-Seal, Advanced Poly-Pack, Advanced Poly-Bag, and Advanced Bag.

Limited Warranty and Disclaimer

Warranty period is 12 months or 1,000,000 cycles whichever comes first. The warranty commences on the date of delivery of the equipment to the Purchaser. APPI warrants to the Purchaser that the equipment is free from defects in workmanship or material under normal use and service. During the warranty period, APPI agrees to repair or replace, at its sole option, without charge to Purchaser, any defective component part of the equipment. To obtain service, Purchaser must return the equipment or component to APPI or an authorized APPI distributor or service representative in an adequate container for shipping. Any shipping charges, insurance, or other fees must be paid by Purchaser and all risk for the equipment shall remain with Purchaser until such time as APPI takes receipt of the equipment. Upon receipt, APPI, the authorized distributor or service representative will promptly repair or replace the defective component and then return the equipment or component to Purchaser, shipping charges, insurance, and additional fees prepaid. APPI may use reconditioned or like new parts or units, at its sole option, when repairing any component or equipment. Repaired products shall carry the same amount of outstanding warranty as from original purchase. Any claim under the warranty must include a dated proof of delivery. In any event, APPI's liability for defective components or equipment is limited to repairing or replacing the components. This warranty is contingent upon proper use of the equipment by Purchaser and does not cover: expendable component part such thermocouple wire, heater cartridge, rollers, bushings, and the like; or if damage is due to accident, unusual physical, electrical or electromechanical stress, neglect, misuse, failure of electric power, water damage (from airlines), improper environmental conditions, transportation, tampering with or altering of the equipment, packaging of corrosive or contaminating products or other products damaging to components, and equipment or components not owned or in the possession of original Purchaser. APPI will not be liable for loss of production, profits, lost savings, special, incidental, consequential, indirect, or other similar damages arising from breach of warranty, breach of contract, negligence, or their legal action even if APPI or its agent has been advised of the possibility of such damages or for any claim brought against the Purchaser by another party. This warranty allocates risks of equipment failure between Purchaser and APPI. APPI's pricing reflects this allocation of risk and the limitations of liability contained in this warranty. The warranty set forth above is in lieu of all other express warranties, whether oral or written. The agents, employees, distributors, and dealers of APPI are not authorized to make modifications to this warranty, or additional warranties binding on APPI. Accordingly, additional statements such as dealer advertising or presentations, whether oral or written, do not constitute warranties by APPI and should not be relied upon. Warranty on equipment is considered void when outstanding balances become delinquent (over 30 days late - 60 days after ship date). Equipment Integration to other Equipment: APPI assumes no responsibility for the integration of its products to other products or within a system unless APPI performs the integration, testing and provides the results of the tests to the purchaser in writing. Furthermore, APPI assumes no responsibility for bag sizing whether suggested or recommended.

Table of Contents

Chapter 1: Introduction	6
1.1 Welcome	7
1.2 Overview	7
1.3 Standard Features	7
1.4 System Integration	8
1.5 Available Options	9
1.6 Using this Manual - Typographical Conventions	11
1.7 Contact Information	11
1.8 Warranty Registration	13
Chapter 2: Safety, Getting Started	14
2.1 Chapter Summary	15
2.2 Safety, Risks	15
2.3 Installation Procedures	16
2.4 Note on Adjustments to the T-1000-S14	17
2.5 Air and Power Requirements	17
2.6 Assembly Instructions	17
2.7 Air and Power Hookup	18
2.8 Main Power	22
2.9 Bag Threading	22
2.10 Cycle Operation of the T-1000-S14	22
2.11 Quick Setup Procedures	23
Chapter 3: Touch Screen Operation	26
3.1 Touch Screen Operation	27
3.2 Touch Screen Specifications / Features	27
3.3 Touch Screen Program, Overview	27
3.4 Introductory Screen	27
3.5 Operation Screen	28
3.6 Main Menu	28
3.7 Settings Screen	28
A. Fill Time	29

B.	Air Pulse.....	29
C.	Seal Point	29
D.	Seal Time	29
E.	Reverse.....	30
F.	Blow Off	30
G.	Index Speed.....	30
H.	Seal Temperature	30
3.8	Options Menu.....	30
3.9	LS-10 Load Shelf.....	31
3.10	FS-10 Flat Seal Assembly.....	31
3.11	FS-30 Heavy-Duty Flat Seal Assembly	31
3.12	CS-10 Compartment Seal	32
3.13	TS-10 Twin Seal Feature	32
3.14	Ti-1000Z Printer	32
3.15	CF-10 Counting Funnel	33
3.16	BO-30 Bag Opening Device	34
3.17	LC-10 Light Curtain	34
3.18	BO-20 Bag Open Detector.....	36
3.19	TIZ RAP / Accumulator.....	36
3.20	AF-10 Accumulating Funnel	36
3.21	US-5000 / US-5500 Semiautomatic Net Weigh Scale	37
3.22	PB-20 Optical Palm Buttons.....	37
3.23	TS-10 Trim Seal Assembly.....	37
3.24	ES-10 E-Stop Circuit	37
3.25	Adjustable Stand Screen	38
3.26	DF-20 Part Diverter (Diverting Funnel)	38
3.27	MV-20 Seal Validation	39
3.28	Medical Flat Seal	40
3.29	BF-10 Bag Deflator.....	40
3.30	UF-5000 Infeed Conveyor Operation Screen	41
3.31	BV-10 Barcode Verification Option.....	41
3.32	Ti-1000 Inline Printer	42
3.33	Counters Screen	42
3.34	Continuous Strip Screen	42

3.35	Temperature Calibration Screen	43
3.36	Technical Assistance & Troubleshooting Screens.....	44
3.37	Bagger Auxiliary Options	44
3.38	Pass Code Setup Screen.....	44
3.39	Bagger Factory Settings.....	45
3.40	Bag Registration.....	47
3.41	Job Save and Recipe Management	48
A.	Internal Memory (PLC)	49
B.	External Memory (USB).....	49
3.42	Memory Files and Data Structures	50
3.43	PLC Info.....	55
3.44	Options Enable Screen.....	55
3.45	License Activation	56
3.46	Production Graph and Temperature Graphs	57
3.47	Operation Mode Timers, Alarms, & Alarm Data	57
3.48	Bagger Machine Info	58
3.49	Warning and Message Screens	58
Chapter 4: Adjustments Maintenance, Troubleshooting		60
4.1	Machine Adjustments	61
4.2	Compression (Nip) Roller Adjustment	61
4.3	Dancer Assembly Adjustments (Roller Shaft).....	64
4.4	Dancer Bar and Brake Strap Adjustment.....	64
4.5	Upper Roller Guides	64
4.6	PTFE Adjustment.....	66
4.7	PTFE Replacement	66
4.8	Pressure Bar Adjustment.....	67
4.9	Sealer Cylinders Adjustment	67
4.10	Pressure Bar (Rubber) Replacement.....	67
4.11	Anti-Jam Adjustment.....	71
4.12	Heater Cartridge Replacement.....	73
4.13	Replace Thermocouple Wire	75
4.14	Preventative Maintenance and Scheduled Maintenance.....	75
4.15	Preventative Maintenance Checklist.....	76
4.16	Scheduled Maintenance Chart	77

4.17	Preventative Maintenance Chart	77
4.18	Spare Parts Kits.....	78
4.19	Troubleshooting Guide	80
4.20	Troubleshooting Checklist.....	80
4.21	PLC IO Listing.....	82
4.22	Schematics	86
A.	Electrical Drawings.....	86
B.	Pneumatic Piping Diagrams.....	99
Chapter 5: Parts and Drawings		108
<hr/>		
5.1	T-1000-S14 Advanced Poly-Bagger.....	109
5.2	Base Assembly.....	111
5.3	Upper Column Assembly.....	112
5.4	Covers and Guarding	113
5.5	Flat Load Shelf Assembly.....	114
5.6	Dancer Assembly	115
5.7	Touch Screen Assembly	118
5.8	Seven Inch Touch Screen.....	119
5.9	Main Frame Assembly.....	121
5.10	Upper Roller Assembly.....	123
5.11	Air Knife Assembly	124
5.12	Sealer Frame Assembly: Drop Frame.....	126
5.13	NBO Wide Seal Frame Assembly.....	129
A.	Pressure Bar Subassembly	132
B.	Heater Bar Subassembly	133
C.	PTFE Guide Subassembly	134
D.	Grooved Roller Mounting Subassembly.....	135
E.	Bag Finger Grounding Subassembly	136
F.	Latch Subassembly	137
G.	Manifold Assembly.....	138
5.14	Electrical Panel	139
5.15	Bag Blow Off (Optional)	141
5.16	Bag Deflator (Optional)	142
5.17	Notes	143

Chapter 1: Introduction

Welcome

Overview

Standard Features

System Integration

Available Options

Using this Manual - Typographical Conventions

Contact Information

Warranty Registration

1.1 Welcome

Now that you have decided to upgrade your packaging facilities with the T-1000-S14 Advanced Poly-Bagger™ from Advanced Poly-Packaging, Inc., we thank you for selecting our equipment, materials, and service. Where labor reduction and fast changeover are important, the T-1000-S14 uses Advanced Poly-Bags (pre-opened bags on rolls) manufactured by Advanced Poly-Packaging, Inc. Extensively equipped with several "built-in," ready-to-use options, the T-1000-S14 can package various industrial, medical, molded and food products. With bag sizes that range from 4" x 3" to 11" x 16" and mil thickness from 1 mil to 4 mils, we hope the T-1000-S14 will meet all your bagging needs. T-1000 Advanced Poly-Bagger™ is a general-purpose bagging system designed for manual or automatic packaging of a variety of products.

1.2 Overview

The T-1000-S14 Advanced Poly-Bagger™ is a general-purpose bagging system designed for manual and automatic packaging of a variety of products. The T-1000-S14 is designed to lower your packaging costs with high speeds, versatility, reliability, and simplicity.

High Speeds: Indexes, opens, seals, and tears off a bag at very high rates of speed. Actual packaging speed depends on the bag size, equipment options, product characteristics and loading method.

Versatility: Mobile on rugged castors for packaging at any production station in your facility. Ideal for numerous short runs with virtually no production loss for job changeovers since all that is required is a roll change and recalling the bag settings from memory.

Reliability: Crafted from the highest quality components and materials to withstand the most rigorous manufacturing environment. Sturdy mounts with castors and a rugged frame guarantee long life and usefulness with minimal maintenance.

Simplicity: A user-friendly, menu-driven touch screen program allows operators to set up the bag, options, and auxiliary equipment, save settings in memory and recall those settings for repeat runs.

1.3 Standard Features

The machine comes standard with the following features:

Anti-Jam Device: Detects rigid objects of at least 3/8" to safeguard the equipment and product. During the loading and sealing operation, this device will automatically reverse the pressure bar and discontinue cycle operation if an obstruction is detected.

Auxiliary Automatic Operation – Integrates automatically to vibratory counters, scales and other in-feed equipment.

Castors Assembly: Rugged castors are standard for plant mobility.

Communications Ports: Provides for auxiliary communications and screen data transfer.

Continuous Strip Option: Leave bags connected in an "endless" strip or a predetermined number of strips of sealed bags.

Counters – Preset, Total and Maintenance counters are provided.

Energy Conservation and Component Saver: To extend its life and conserve energy in your plant, the T-1000-S14 is programmed to sequentially shut down components when not in use for extended periods of time. Electric current to the heater bar will discontinue and place the T-1000-S14 in Stop mode during a preset period of nonuse. Shortly thereafter, air flow will be shut off, preserving compressed air. A screen saver is also provided.

Internal (PLC) and External (USB) Recipe Management System: Stores up to twenty-four recipe settings internally, or hundreds of recipes externally. Optional Ethernet card can allow for remote recipe management.

Maintenance Counter / Chart: Periodically check this counter (total machine cycles) to determine preventative maintenance and component inspection intervals.

Pass Code Protection: Settings screens can be protected from alterations by unauthorized individuals. Once turned on, this function acts as a "screen save" feature. After a preset amount of time, the pass code screen will be displayed from the Bagger Operation screen. Factory settings are protected by a Level 1 pass code and should only be accessed by authorized maintenance personnel.

Predetermining Counter: Preset the T-1000-S14 to stop after a predetermined number of bags have been packaged. Set the quantity of finished bags to complete a work order or fill a shipping container. Once the work order is complete or the container is full, the T-1000-S14 stops to alert the operator to begin the next work order or to push aside the box and begin filling another. Pressing anywhere on the screen resets the counter and starts the bagging operation with minimum delay.

Totalizing Counter: Reset this counter at the beginning of each shift or day to record packaging production over a period of time.

1.4 System Integration

The T-1000-S14 is preprogrammed to integrate automatically with major brand vibratory counters and feeders, weigh scales, volumetric fillers, auger fillers and infeed conveyors. As an OEM for numerous equipment manufacturers of infeed systems, we offer the best available system with the T-1000-S14 Advanced Poly-Bagger as the integral packaging component. However, APPI cannot be responsible for the successful integration of third party equipment, unless approved and integrated by APPI.

FREE CONSULTATION AND PRODUCT EVALUATION: We invite you to call to discuss your packaging requirements and our free product packaging analysis.

1.5 Available Options

Although the T-1000-S14 is equipped with many "built-in" options, various auxiliary options and equipment can easily be added for special purpose packaging. The following options may be purchased from Advanced Poly-Packaging, Inc:

AF-10 Accumulating Funnel: A special purpose funnel that collects and holds product until it is ready to be dropped. A funnel to help contain the product can also be inserted.

Bag Deflator: This option quickly mounts to the sealer bar and squeezes the air from the bag while sealing.

Bag in Bag Option: A conveyor feeds bagged product to a second bagger to be bagged again.

Bag Out Sensor: If the bag material ends, a message will be displayed indicating that the machine is out of bags or that a threading or web breakage issue has occurred.

Base Height Adjustment: An electronic mechanism that raises or lowers the base of the bagger, allowing for more versatility and convenience. Without this option, the operator must raise or lower the bagger manually.

BO-20 Bag Open Detector: This option will detect whether or not a bag is blown open, or whether or not a funnel is inserted into the bag for validation that the bag is ready to receive product.

BO-30 Bag Opening Device: This device enters the bag with one or more "fingers" and pulls the bag open to a stop.

BV-10 Barcode Verifier: Verifies that a barcode is readable. If no barcode is detected, or if a barcode is not correctly formatted (as per software settings in the barcode verifier), then a "No Read" message will be displayed.

CF-10 Counting Funnel: This option automatically cycles the bagger when a preset number of parts have fallen through the funnel.

CS-10 Compartment Seal: Seals the bag twice to create two separate compartments within the same bag.

DF-10 Diverting Funnel: This feature is used to count bags from the bagger and divert them for further packaging operations, including counting into cartons.

Dual Printing: Special programming allows the T-1000-S14 to operate with both the Next Bag Out printer and an offline printer in order to print on both sides of the bag. The offline printer is mounted upside down on the back of the bagger.

E-Stop: This option can be used to stop the cycle operation of the T-1000-S14 and possibly other auxiliary infeed or outfeed equipment purchased with the T-1000-S14.

FS-10 Flat Seal Assembly: Helps decrease/eliminate wrinkles in the seal by pulling the sides of the bag. Increases bag integrity.

FS-30 Heavy Duty Flat Seal Assembly (Drop Frame): Uses two movements to further assist in flattening the film to decrease wrinkles or folds in the seal.

LAN Connection: Provides for Ethernet communication.

LC-10 Light Safety Curtain: If funnels are removed, APPI highly recommends the addition of this option to prevent injuries. This option, when activated, prevents outputs (voltage) to valves that cause the seal bar to activate. Additionally, the stepper motor stops when blocked.

LS-10 Load / Support Shelf: Provides support for heavier packages when dropped into bag. Sizes: 10", 15" or 20" long.

MV-10 Seal Validation: Additional components provide a secondary means of detecting a failure or out of range condition for components that affect seal quality.

NBO Next Bag Out Printer: An inline printer installed within the T-1000-S14 capable of printing the next bag out in the bagging sequence. This feature prevents mislabeling of pharmaceuticals, prescriptions or high cost items and allows part numbers or other printing information to be changed with every bag.

OFS-10 Output Fault Signal with SL-10 Stack Light: For automatic bagging operations with third party or production equipment, this signal provides a fault when the bagger is inoperative (due to out of bag conditions or other faults).

PB-20 Dual Palm Buttons: Decreases the possibility of injury to hands and fingers. The operator must push two buttons simultaneously to actuate the seal bar.

Roll-a-Print 1400 or 2800 Single or Dual Thermal Inline Printer: Prints bar codes and graphics directly to the surface of the front or both the front and back of the bag.

Ti-1000 Thermal Transfer Inline Printer: Prints bar codes, graphics, etc. by downloading pre-formatted labels, generated via label software. (PC or Terminal and software required)

TS-10 Trim Seal Assembly: Trims excess film from the bag above the seal to enhance the appearance of the package. Great for retail products.

Twin-Seal™: Seal the bag a second time, 3/8" from the first seal, for additional bag integrity.

UC-2400 Vibratory Parts Counter: Automatic parts counter feeds fasteners, electronic components, injected molded parts and many other types of product, then drops the final count into the bag, carton, or infeed conveyor.

UF-2000 Takeaway Conveyor: Removes packaged product to a packing station or directly feeds a carton or table, conveying the product from floor level. The conveyor fits perfectly underneath the T-1000-S14 and takes the product away. Small, lightweight, and equipped with castors, use this conveyor anywhere in the plant. Designed for 24 hour / 7 days a week operation.

UF-5000 Infeed Conveyor: Kit packaging infeed conveyor. Instead of loading parts directly into the bag, load parts into compartments on the conveyor. Packaging kits can be loaded into the compartments by hand or automatically with parts or scales.

US-4000 Check Weigh Scales: When you must guarantee the contents of the bags or kits, APPI offers check weigh scales with incredible accuracy, speed, and reliability. A history of weights is standard, along with job/recipe saves.

US-5000 / 7000 / 9000 Semiautomatic (US-5000) or Automatic Scale (US-7000 and US-9000): Feeds a weighed/counted batch of product into bags.

Other options may have been added since the date this list was printed. Please call for additional or custom options pricing.

1.6 Using this Manual - Typographical Conventions

The following manual conventions are frequently used to assist in understanding important information, alerting the operator of potentially dangerous or damaging practices, and the normal functions of the

T-1000 Advanced Poly-Bagger™.

text Normal text

<ENTER> Used to show Touch Screen keys

Italics Used for emphasis

Note: Identifies important information.

CAUTION: Warning messages - To avoid physical harm, damage to equipment or damage to the product. Be sure to read these messages carefully.

1.7 Contact Information

To better serve your bagging needs, call **(330) 785-4000** or toll free **1-(800) 754-4403** for convenient service solutions, Monday through Thursday, 9:00 AM to 5:30 PM EST, or Friday 9:00 AM to 5:00 PM EST. For technical assistance with current machinery, ask for **Service**. To order spare parts for your system, ask for **Parts**. To order auxiliary equipment for your current system, ask for **Machine Sales**. To place an order for bags, ask for **Bag Sales**.

You may also contact any of these departments by email:

Reach Service at Service@advancedpoly.com

Reach Parts at Parts@advancedpoly.com

Reach Machine Sales at MachineSales@advancedpoly.com

Reach Bag Sales at Bagsales@advancedpoly.com

For general inquires: Sales@advancedpoly.com

Or visit us online at www.advancedpoly.com

In order to provide the best service possible, please have model and serial number ready.

1.8 Warranty Registration

This section must be completed and returned to Advanced Poly-Packaging, Inc. to register the T-1000 Bagger for Warranty Protection.

Serial Number:

(Serial Number located on the back panel)

Company Name and Address

Contact Name(s) / Title(s) / Phone Number

<hr/>	<hr/>
<hr/>	<hr/>
<hr/>	<hr/>

Please fax or mail this page to:

Service Manager
Advanced Poly-Packaging, Inc.
1331 Emmitt Road
Akron, OH 44306
USA

Fax # (USA) 330-785-4010

Or email the information above to: service@advancedpoly.com

Chapter 2: Safety, Getting Started

Chapter Summary

Safety, Risks

Installation Procedures

Note on Adjustments to the T-1000-S14

Air and Power Requirements

Assembly Instructions

Air and Power Hookup

Main Power

Bag Threading

Cycle Operation of the T-1000-S14

Quick Setup Procedures

2.1 Chapter Summary

This chapter describes procedures to receive and set up the T-1000-S14, including uncrating instructions, environmental, air and power requirements, risks, required safety precautions, quick start procedures assembly instructions and height adjustments. Additionally, this chapter describes safety precautions, how to power on the T-1000-S14 and how to properly thread bags through the machine.

2.2 Safety, Risks

The equipment has been designed with features to reduce the possibility of injury. Despite safety precautions, operators may receive lacerations, minor burns or crushed or broken bone injuries if coming in contact with the heater bar or other moving components. Please carefully read the following precautions to operate the equipment properly and avoid injury.

Although no special personal protective equipment is required to operate the equipment, eye protection, gloves or other protection should be worn depending on the characteristics of product being packaged or the method of loading the product.

Please carefully read the following precautions to operate the equipment properly and avoid injury:

CAUTION: Initial Setup of the machine must be performed by Specialized Personnel. Qualified Service Engineers should uncrate, assemble (if required), test and connect power sources, test the equipment for proper operation and otherwise setup the equipment for use.

CAUTION: Maintenance must be performed by Specialized Personnel. Qualified Service Engineers must remove guards or covers to gain access to electrical or mechanical areas.

CAUTION: To avoid injury do not reach under the equipment or guards. Do not place hands or fingers in the seal area, near the seal or heater bar, load shelf, or other moving components.

CAUTION: To avoid injury, do not operate the equipment if funnels, guards, or covers or other access panels have been removed. If any of these safety measures have been removed or modified or if any openings have been increased, the operator will have access to moving components and extreme temperature areas that can cause crush, cut, or burn injuries to hands or fingers.

CAUTION: To avoid injury, do not reach under guards or elsewhere under the machine.

CAUTION: Do not remove or loosen fasteners on the frame. If loosened the equipment may drop suddenly causing injury or damage to the machine.

CAUTION: Do not attempt to adjust the height without assistance and without supporting the weight of the machine. Attempting to make a height adjustment without assistance could cause the machine to drop suddenly, causing severe injury. APPI offers several optional accessories that can reduce the risk of injury during height adjustments. These accessories include carts, motorized height adjustment components and stabilizing bars.

CAUTION: *Ensure that any height adjustments allow for sufficient movement of the operator. Improper height adjustments could negatively affect operator movement, causing strain, added stress, discomfort, and fatigue.*

CAUTION: *Be careful when opening the seal frame as it may drop suddenly causing injury or damage to the equipment.*

CAUTION: *To avoid injury, avoid coming in contact with pinch points including rollers, automatic funnel doors or other moving components.*

CAUTION: *To avoid injury, avoid contact with Roller "Fingers" as they may be sharp.*

CAUTION: *Exercise care when adjusting or relocating the touch screen. Movement of the touch screen could cause unexpected movement of the machine and injury to the operator.*

CAUTION: *If control or air pressure settings are set too high, higher noise levels may result from increased part on part contact or part on machinery contact. Limit these settings and add guards or covers to reduce airborne noise.*

CAUTION: *Exercise extreme care when clearing jams, replacing materials, changing controls or mechanical settings, and cleaning internal parts. Be sure to de-energize energy sources prior to removing guarding. Failure to do so may result in unexpected movement or flying objects, which could cause crush, cut, or eye injuries.*

CAUTION: *Maintenance must be performed by specialized personnel. Qualified service engineers must remove guards or covers to gain access to electrical or mechanical areas.*

CAUTION: *Maintenance must be performed regularly to ensure that the machine is operating properly and to protect against injury. Routine maintenance includes: periodic inspections, the replacement of worn or damaged components, the tightening of loose bolts or components, and regular cleaning and adjustments. Contact APPI and/or service centers for service support if there is not sufficient maintenance staff at your facility to perform regular maintenance.*

2.3 Installation Procedures

The T-1000-S14 is transported as a single unit in a custom crate designed to protect the machine during shipment. It is shipped completely assembled except for a few items that are easily attached during installation. A final adjustment is also necessary to ensure proper placement of the touch screen, dancer assembly, foot switch, funnel, and guards.

Unpacking: After removing the stretch wrapping, remove the outer crate from the skid that contains the T-1000-S14. Unfasten the base support brace from the skid. Carefully lower the T-1000-S14 from the skid. Transport the T-1000-S14 to the operating location prior to placing the touch screen in position and unfastening the dancer assembly.

Operating Environment: The T-1000-S14 should be placed in an area free of excessive heat, moisture, dirt, and dust. Operating room temperature should range from 50°F to 100°F (10°C to 37.77°C).

2.4 Note on Adjustments to the T-1000-S14

Upon receipt, it is not unusual for the T-1000-S14 to be out of alignment due to shipping and excessive handling. Unless physically damaged, the T-1000-S14 will function properly after minor adjustments are made. Refer to Chapter 4 for information on adjustments to the T-1000-S14.

2.5 Air and Power Requirements

Power Requirements: Provisions must be made for 115 VAC, 50/60 Hz line current with ground. The full load current for the T-1000-S14 is 12 Amps. APPI recommends a dedicated 20 Amp circuit for the T-1000-S14.

Note: A qualified electrician should ensure that voltages are as required, amperage is sufficient, power outlets are the required 115 VAC and power outlets are properly grounded before hooking up the power. If the unit is not properly grounded, it will produce a shock and will not function properly.

Air Requirements: At least 2 CFM free air is required, regulated to 60 PSI (413.68 kPa). Air should be dry and oil-free.

Note: Running the T-1000-S14 at a higher PSI setting than 60 PSI (413.68 kPa) will cause excessive wear and may cause damage to components on the machine or parts being packaged. The anti-jam function may also be adversely affected.

2.6 Assembly Instructions

Choose an operating location considering traffic flow, availability of bag supplies, supply of product to be packaged, takeaway of finished packages, placement of auxiliary infeed equipment and placement of takeaway conveyor(s). At the operating location, the first step is to remove any inner packaging, banding, or wires.

Touch Screen Assembly / Position: The touch screen has been secured for transportation in a "face-in" position with protective wrapping. Holding the touch screen to prevent it from falling, loosen the set screw located in the clamp collar at the top of the upper "T" column. Pull the shaft from the clamp collar approximately 6" (15.24 cm) and tighten the collar. Holding the touch screen module, loosen the "ball" clamp lever and position the touch screen. See Figure 2-1.

CAUTION: *To avoid damage to the touch screen module, hold the screen until it is in the desired position and then be sure the screws and ball clamp lever are securely tightened.*

Dancer Assembly: The dancer assembly, located on the stand at the rear of the T-1000-S14, is secured with tape strapping during shipment. After the removal of the strapping, the dancer should be checked to ensure it will rotate freely in a semicircular path. The shaft assembly may then be inserted into the dancer frame brackets so it is over the brake stop for tension.

CAUTION: *The seal bar should not come in contact with the funnel during sealing. Raise the funnel to avoid contact.*

CAUTION: *To avoid injury, do not operate the T-1000-S14 without a funnel, guard or covers properly positioned. APPI offers a variety of funnels and chutes. Guarding may need to be added to prevent operators from reaching in, around or under the guard or funnels.*

CAUTION: *To avoid injury, do not reach underneath guards while the machine is plugged in.*

Machine Height Adjustment: The height of the T-1000-S14 is adjustable. To change the height of the machine, three people are required; two people holding the weight of the machine, and one person loosening the two bolts located on the leg and clamping the outer leg to the inner leg. See Figure 2-2. Raise or lower the T-1000-S14 to the desired height and tighten the two bolts.

CAUTION: *Unless properly supported, the T-1000-S14 will drop suddenly when loosening the height adjustment bolts. This may cause damage to the machine or injury to individuals.*

CAUTION: *Do not attempt to adjust the height without the assistance of at least two other people supporting the weight.*

2.7 Air and Power Hookup

This section describes how to hook up air and power and the air and power requirements.

Note: *A qualified electrician should ensure power outlets are the required 115 VAC and properly grounded before hooking up power. If the unit is not properly grounded, it will produce a shock and the machine will not work properly.*

The air supply should be fed to the T-1000-S14 with 3/8 ID flexible tubing. This tubing affixes to the coupler adapter (quick disconnect not provided). Connect the air to the regulator by holding the regulator firmly in one hand and pushing the airline connector on the male regulator connector. After connecting air, the regulator should be adjusted so the gauge reads 60 PSI (413.68 kPa). Insert the T-1000-S14 power cord into a 115 VAC, 60 Hz, grounded power outlet.

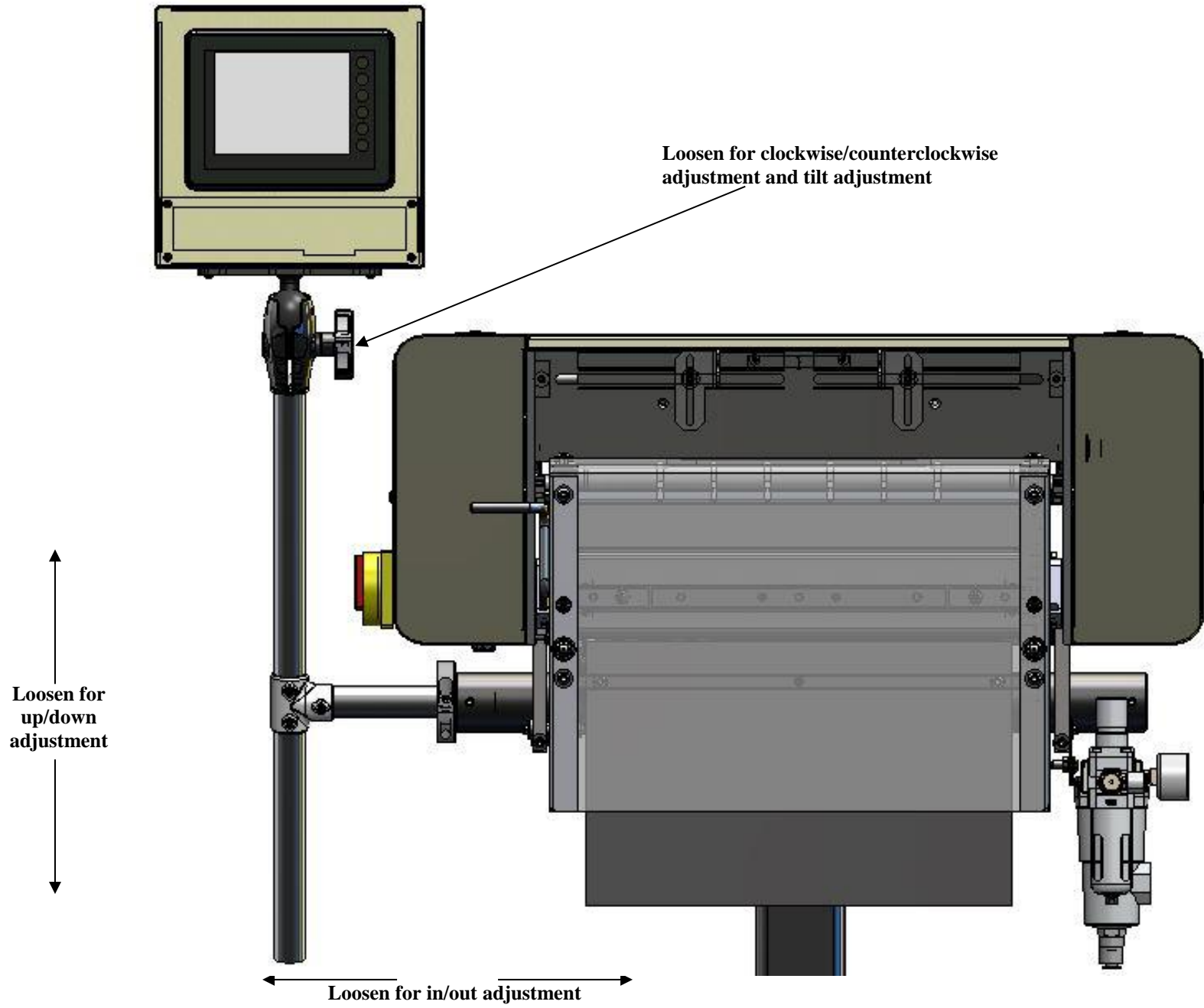

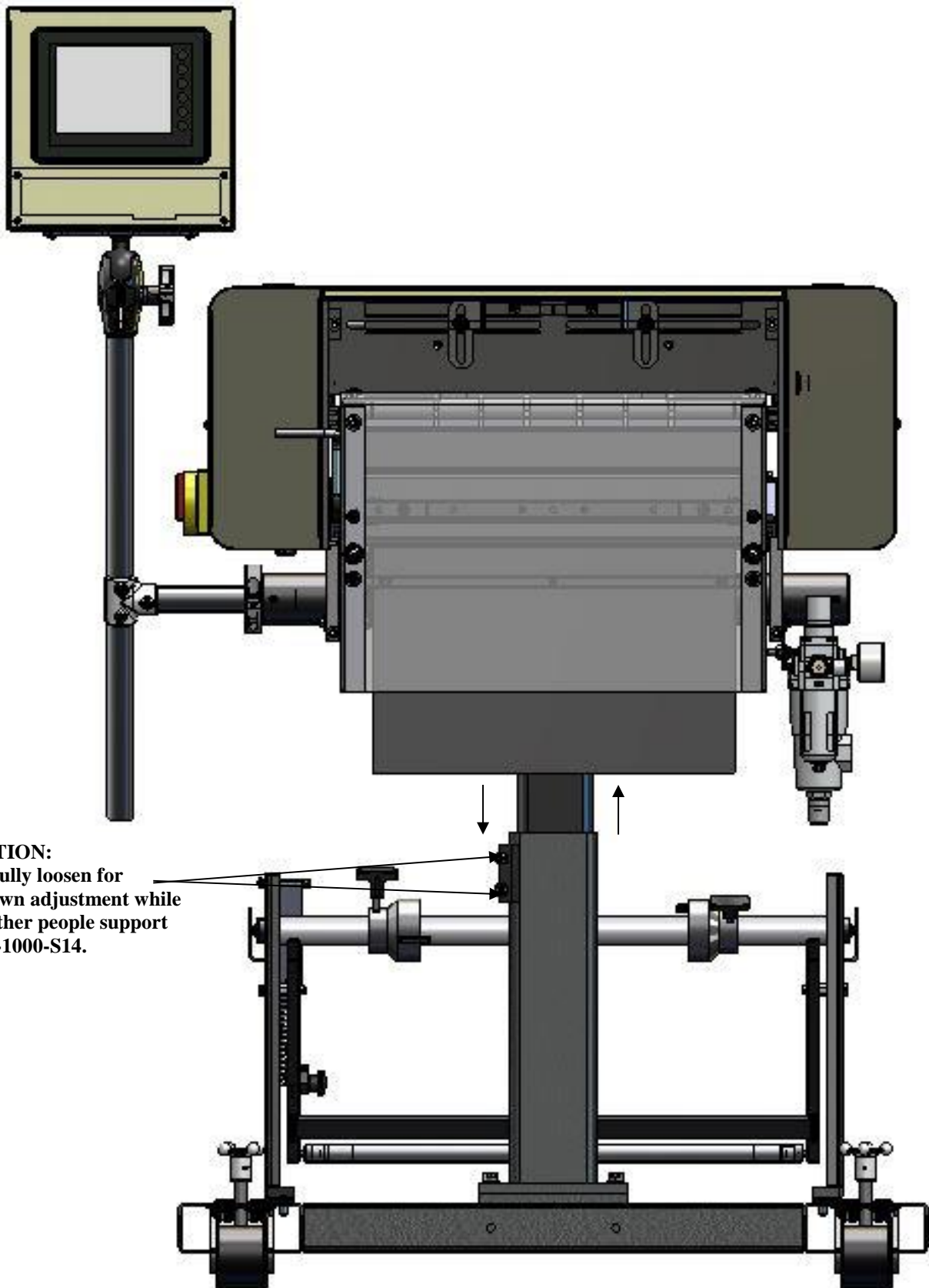

CAUTION:
Carefully loosen for
up/down adjustment while
two other people support
the T-1000-S14.

CAUTION:
If the bagger is not held in position by two people, the
weight of the machine may cause it to drop suddenly,
causing severe injury.

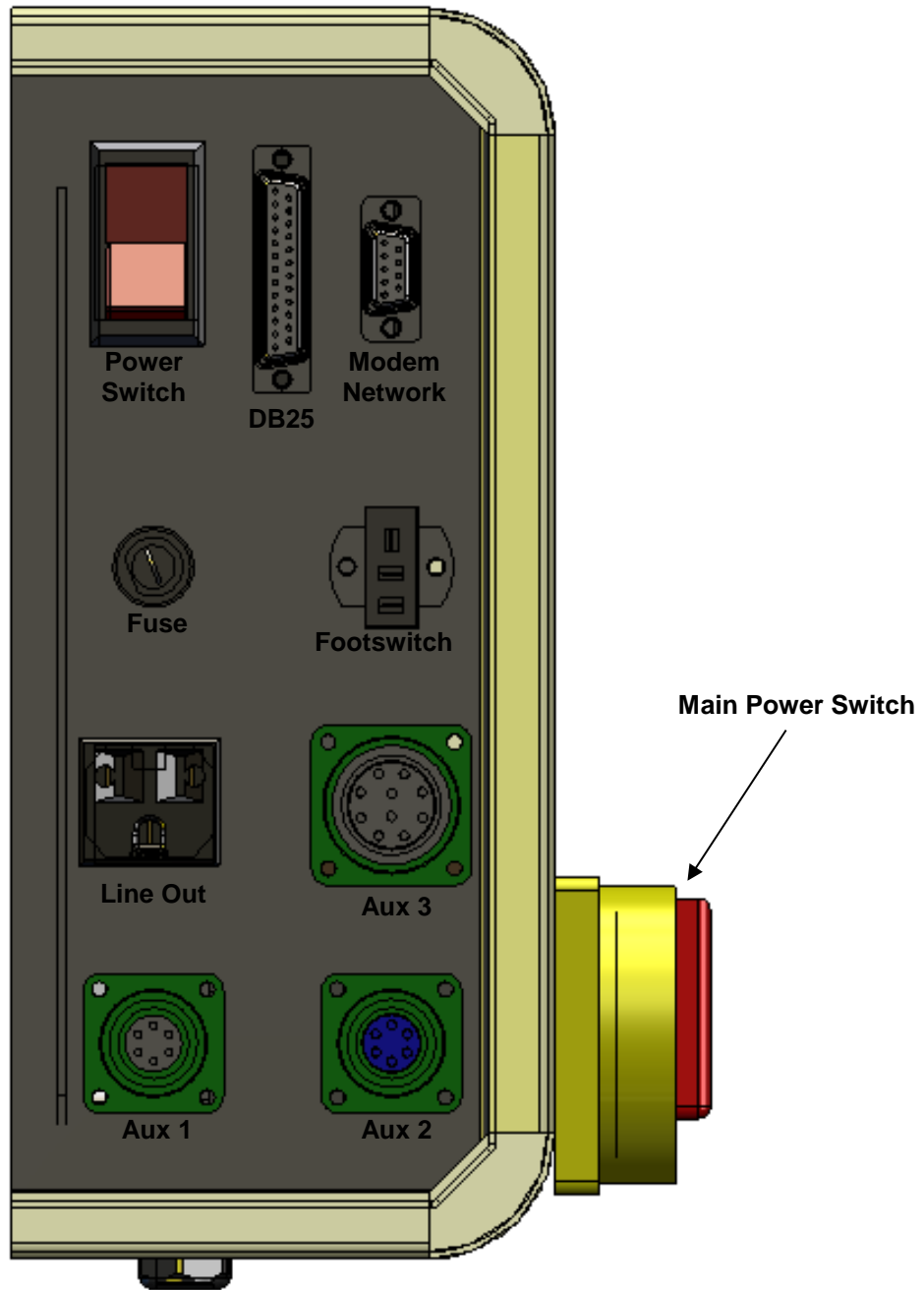

2.8 Main Power

The main power switch is located on the side cover of the machine. See Figure 2-3. To turn the T-1000-S14 on, turn the switch counterclockwise from its vertical OFF position to its horizontal ON position. The green Power light on the touch screen will illuminate and the Introduction screen will be displayed. The program version will also be identified. The Introduction screen will only appear for a few seconds until automatically changing to the Bagger Operation screen or Main Menu.

Note: *If the touch screen does not power up to the Introduction screen, see Chapter 4 for Troubleshooting Checklist.*

2.9 Bag Threading

The first step to threading the machine is to place a roll of bags on the shaft. Remove one of the chucks from the shaft by loosening the chuck knob and sliding the roll of bags over the shaft, locking the chuck pin in the small hole in the core plug. Tighten the knob. Replace the second chuck, also locking the chuck pin to the core plug. Remove the tape from the bags so that the bags fall freely and hang down from the top of the roll towards the back of the machine. Insert the right side of the roll shaft in the right side of the shaft holder (circular holder). Then drop the roll shaft in the slot located on the left side of the dancer assembly.

Center the bags on the shaft by loosening the chuck knobs and sliding the roll of bags, along with the chucks, to the desired location. Ensure the chuck pins remain in the core plug holes when sliding left or right. Pull the bags over the roller immediately above the dancer assembly, then down between the roll of bags and the outer dancer roller. Pull the bags around the outer dancer roller, over the rear "guide" roller and into the back of the T-1000-S14. Push the bags at least halfway through the machine.

From the front of the T-1000-S14, lower the frame by slowly pulling the frame handle forward and downward while holding the guard assembly, supporting the weight of the seal frame assembly.

CAUTION: *You must support the weight of seal assembly while lowering it with the handle. Otherwise, you may drop the seal assembly, possibly causing personal injury or damage to the equipment.*

Carefully reach inside and pull the bags through the front of the T-1000-S14 so that one bag is centered on the roller. Ensure only one bag extends through the front of the machine. Slowly raise the frame by pulling forward and upward on the handle while holding the bag in position. Holding the guide roller shaft, slide the roller guides approximately 1/8" (0.31 cm) from the sides of the bag to assist the tracking of the web of bags.

CAUTION: *Roller "fingers" may be sharp. To avoid injury when reaching into the T-1000-S14, ensure that you do not come in contact with the roller fingers.*

Note: *The roller guides are for fine adjustments only, after proper tracking has been achieved. If the web of bags is not properly tracking, make proper adjustments. If not tracking properly, the web of bags may "ride" up the side of the guides, causing the bags to fold over.*

Two Threading Diagrams are available based on the design of the machine, with or without a printer. See Figure 2-4 and Figure 2-5. If your machine has special features or other equipment that changes the function of the bagger, the specific threading diagram will be included with that particular manual or addendum. If you need further assistance with bag threading, please contact APPI Technical Support.

2.10 Cycle Operation of the T-1000-S14

If all prior installation procedures have been performed properly, the T-1000-S14 should be in its operating location with air and power connected. All guards, funnels and covers should be in position and securely fastened.

Locate the foot switch and plug it into the rear foot switch connector. See Figure 2-3. Press the foot switch to index one bag through the “nip” rollers. If a foot switch is not being used, press the **Manual Cycle** button. One bag should index, blow open and stop between the pressure bar and the heater bar. If the T-1000-S14 is not up to temperature, the machine will not cycle unless the **RUN / SETUP** button is toggled to **SETUP**.

If the web of bags breaks prematurely, further adjustments will be required. See Chapter 4 for troubleshooting. If one bag indexed through the machine, press the foot switch a few more times. Each previously indexed bag should detach completely from the web of bags. If the bag is not indexing and/or stopping or not tearing off properly, see Chapter 4 for troubleshooting.

Note: The web of bags may track right or left for a few feet until “settled” on the web path. The roll of bags or the roller guide may require readjustments or realignment after the first few feet of bags are indexed.

Note: If bags were delivered with the T-1000-S14 or the bag size was known to APPI, the T-1000-S14 may be ready to run. Therefore, very few changes to the Bagger Settings screen will be required.

2.11 Quick Setup Procedures

(Perform prior to operating the machine on a daily basis)

Considering that the machine has been setup by Maintenance Personnel, the following quick start procedures should be followed before daily operation of the equipment.

Power off tasks (perform these tasks prior to turning on the power):

Clean the blue rubber roller, print rollers, perforation sensor, idler rollers and product contact surfaces with a clean cotton cloth and alcohol.

Inspect the machine to ensure all guards, covers and funnels are in position.

Inspect the machine for maintenance issues and report issues such as loose or broken components, frayed wires, etc. to maintenance personnel.

Check that the air pressure is set to 60 psi (413.68 kPa).

Power on tasks (perform these tasks after cleaning and inspecting the machine)

Threading: A threading diagram has been provided to illustrate the proper bag path through the machine. It is recommended that the appropriate diagram be copied and mounted to the side cover of the machine.

Setup Cycle Operation: Prior to loading parts, place the bagger in the Start / Manual / Setup mode and press the footswitch or touch the <Manl Cycle> button. Test the bag seals, seal location or other inspection requirements.

Manual Cycle Operation (if applicable): If manually loading parts, load parts into the bag ensuring all parts are going into the bag. Toggle the machine from Setup mode to Manl mode. Press the <Manl Cycle> button on the screen. Inspect the bag seals, seal location or appearance and continue the bagging operation.

Automatic Cycle Operation (if applicable): If loading automatically with a conveyor, counter, or scale infeed system, ensure auxiliary equipment is turned on and press the <Manl Cycle> button to start the system. If all equipment in the system is operating properly, toggle the machine from the Manl mode to the Auto mode.

Figure 2-4

**T-1000-S14 THREADING DIAGRAM
METHOD 1: SINGLE DANCER**

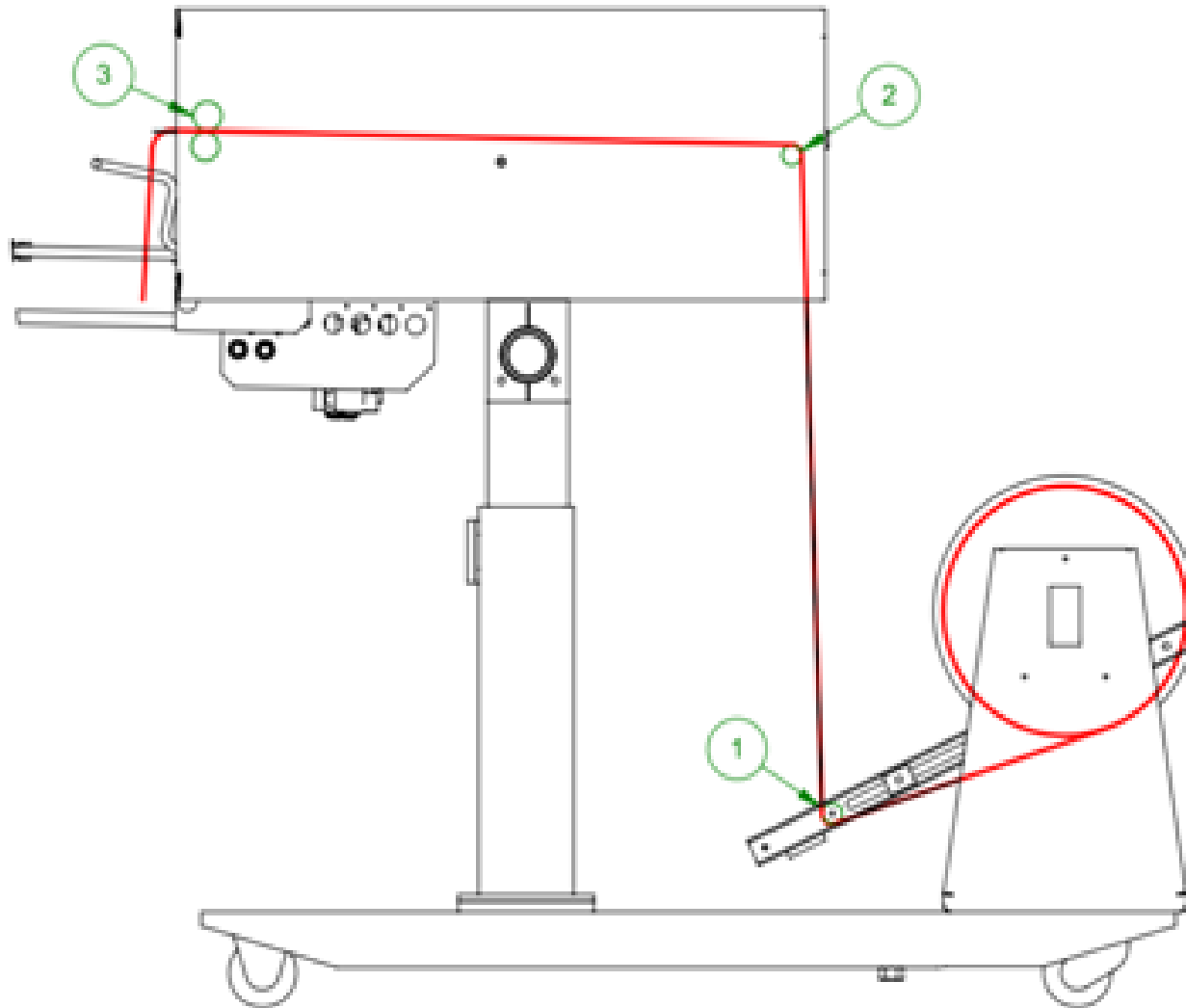
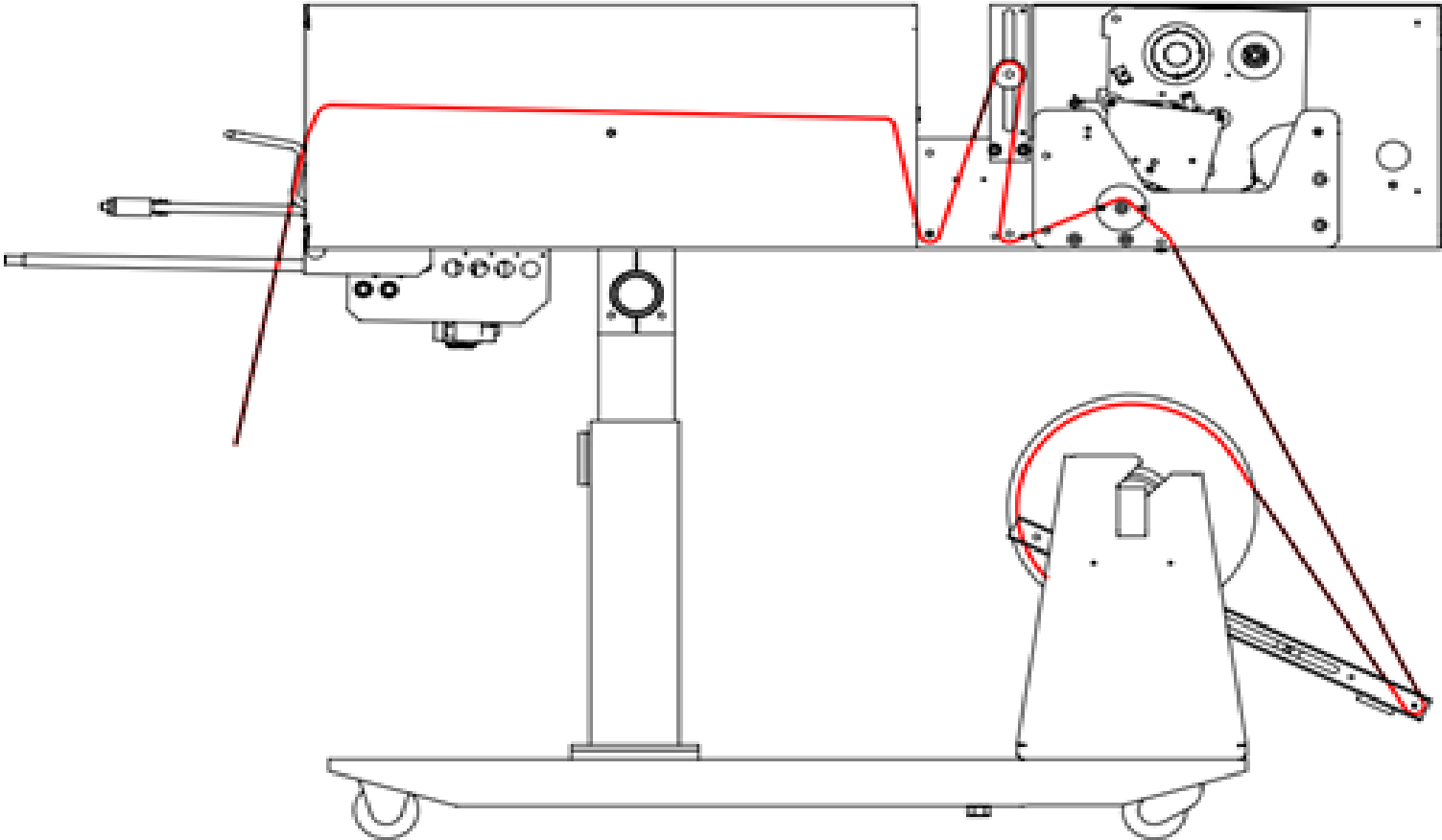

Figure 2-5

**T-1000-S14 THREADING DIAGRAM
METHOD 4: SINGLE DANCER WITH TI-1000Z PRINTER.**



Chapter 3: Touch Screen Operation

Touch Screen Operation
Touch Screen Specifications / Features
Touch Screen Program, Overview
Introductory Screen
Operation Screen
Main Menu
Settings Screen
Options Menu
Ti-1000 Inline Printer
Counters Screen
Continuous Strip Screen
Technical Assistance & Troubleshooting Screens
Bagger Auxiliary Options
Pass Code Setup Screen
Bagger Factory Settings
Bag Registration
Job Save and Recipe Management
PLC Info
Options Enable Screen
License Activation
Production Graph and Temperature Graph
Operation Mode Timers, Alarms, & Alarm Data
Bagger Machine Info
Warning and Message Screens

3.1 Touch Screen Operation

This section describes in detail, the identification, operation, and adjustments of the Touch Screen Program.

3.2 Touch Screen Specifications / Features

Screen, Resolution	7", 800 x 480 pixels, 65,536 TFT Colors
Features	Real time clock, recipes, USB
LCD	65,536 colors, TFT
Memory	11.6 MB
Communication	RS232C
Touch Key Resolution	Free, Analog
Languages	English, Spanish, French, German, Italian, Japanese, Chinese, Korean
Dimension	215 x 156 x 42 mm
Back Light	White LEDs (No maintenance)
Power Supply	24V DC, 0.2A
Protection (Front)	IP65
Conforming	CE, UL, cUL

CAUTION: Do not attempt to reprogram the PLC or touch screen. Doing so may cause an unsafe operating condition. Doing so will also void the warranty. Additionally, do not change the DIP switch settings.

3.3 Touch Screen Program, Overview

The Touch Screen Program is a "user-friendly" menu-driven setup and operation program. Pop-up windows are incorporated for quick and easy setting adjustments. Each time a setting is changed, the settings are saved so that if power is lost, the "job" will be recalled automatically without the need for reprogramming.

A general color scheme has been used to identify functions:

Blue: Background color. Blue is used as a background or text-only color, which when pressed typically does nothing.

Yellow: Menu buttons which will take you to other areas in the program.

Green: Setting buttons used to change settings or mode of operation.

Red: Stop, off functions or warning messages.



Figure 3 - 1

3.4 Introductory Screen

When the T-1000 is turned on, an Introductory Screen is displayed. See Figure 3 - 1. The Introduction screen is a welcome screen, and it contains a button that will take the operator to the Operation screen. When turned on, the machine will be in Stop mode.

3.5 Operation Screen

Operation Screen is provided to function with Pass Code Protection function of the machine. If the pass code function is enabled in the Technical Assistance Screen, the touch screen will default to the Operation Screen after a preset time has elapsed. This function prevents unauthorized operators from making setting changes that could affect the operation or performance of the unit. Since no settings are displayed on the Operations Screen, the operator cannot change settings unless a pass code is enabled. See Figure 3 - 2. There are several Operations Screens, which are selected based on the Operation, Auxiliary and Options installed. Figure 3 - 2 is the most basic operation screen sample.



Figure 3 - 2

3.6 Main Menu

Main Menu screen allows the operator to quickly navigate to other areas. See Figure 3 - 3.

Mode toggle buttons are located at the top of many screens:

<Start> / <Stop> toggle button controls operation mode, the mode which enables the equipment to cycle.

<Manl>/ <Auto> toggle button activates the Automatic (paced rate) or Auxiliary Cycle mode.

<Run> / <Setup> toggle button deactivates functions and allows cycling when not at temperature.

Setup mode stops counters, production timers and auxiliary signals so that the equipment can be operated independently in a setup mode.

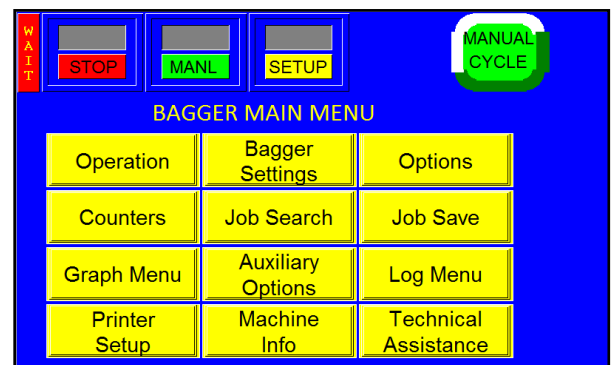

Figure 3 - 3

Ready/Waiting LED (top left corner) displays “Ready” when the heater bar temperature is in the range of acceptance. “Waiting” flashes when the machine is not at temperature. Waiting pauses the operation unless in the setup mode.

3.7 Settings Screen

Bagger Settings Screen provides access to the basic machine settings. Bag size, thickness and product characteristics affect settings required for the proper operation of the machine. See Figure 3 - 4.

All settings will be entered numerically on a keypad. To adjust any value, press the green button of the setting which you would like to change, then enter the value on the number keypad followed by the <Enter> button.

The Settings Menu is where most entries and machine operation settings will occur to setup a new bag size or to run a new product.

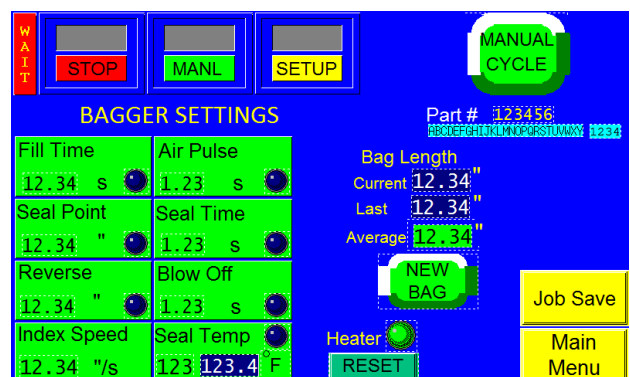

Figure 3 - 4

A. Fill Time

The <Fill Time> button functions differently dependent upon the MODE in which the T-1000 is operating: MANUAL, AUTOMATIC (**AUTO**) mode or AUXILIARY mode.

In the Manual mode with NO accumulating funnel, Fill Time will delay the operation from starting until this time has passed. When equipped with an accumulating funnel, Fill Time will affect the delay time before sealing, after the accumulating funnel door has closed.

In the AUTO cycle mode with no auxiliary in-feed equipment, Fill Time affects the paced rate operation. The bagger will automatically cycle with the Fill Time delaying the seal bar after the bag has been blown open. In the AUTO mode a footswitch is not required.

CAUTION: To avoid physical harm, DO NOT cycle the equipment in the AUTO mode if the funnel, guards, or covers are removed. Since the seal bar actuates automatically, operators must keep fingers, hands, and other parts of the body away from the sealing mechanism and all other moving parts.

AUXILIARY cycle mode, FILL TIME displays the time which a product, automatically filled by auxiliary equipment, must be completely settled in the bag before the seal bar is actuated.

Typical setting for manual loading with a footswitch is 0.0 seconds. Typical setting for auxiliary equipment / automatic loading is 0.5 seconds. The lower the setting, the faster the operation. However, too low of a setting could cause the seal bar to contact the product, possibly damaging the product or seal components.

B. Air Pulse

The amount of time that a burst of air will *initially* blow the bag open. Wider bags and heavier gauge bags require a longer burst of air. Additionally, to increase the *volume* of air from the air pulse tubes, turn the Air Pulse valve counter-clockwise. Flow control valves are located on the right lower side of the seal frame assembly to increase or decrease air through the air pulse tube or blower.

Typical setting for Air Pulse is 0.2 seconds for smaller bags and 0.4 seconds for larger bags. If the index speed is lower (6-15"/Sec), the Air Pulse may need to be longer.

C. Seal Point

Seal point is measured from the top of the bag and can be set to the desired or required location.

The proper positioning of the seal on the bag varies due to bag size and product characteristics. Wider bags or bulky products require greater sealing area. Typical settings for Seal Point: 0.8 inches for narrower bags, 1.2" mid-size widths and 1.5" for wide bags.

New Bag button is used to start an internal program which calculates an average bag length. The perf is used for registration. If a perforation is not detected, the bag will stop in the correct seal position based on the average bag length measurement. A Feed Error message will be displayed if the perf is not detected within a range of acceptance of bag length.

D. Seal Time

Seal Time is the time the heater bar comes in contact with the rubber strip, which is mounted on the pressure bar. Seal time is one of three critical components to obtain a good quality seal. Other critical factors include seal temperature and seal pressure. After adjusting Seal Time, test for good seals and adjust if necessary. Typical settings for Seal Time with temperature set to 400°F is 0.3 seconds for thinner bags (1.5 mil), 0.4 seconds for medium thicknesses (2 to 3 mil) and 0.7 for heavier thicknesses (4 mil). However, the set temperature will

affect the required seal time. If adjusting pressure or temperature, test various seal times until satisfied with the seal quality.

E. Reverse

The distance the bag reverses can be set to cause the perforation to break between the bags. For wider bags, the reverse distance may need to be increased. A typical setting is 1”.

F. Blow Off

A blow off tube is provided to decrease the possibility of bags sticking to the PTFE. Increase the blow off time if bags are not falling from the machine. Typically, the blow off time is set to .15 to .25 seconds.

G. Index Speed

Bag feeding (index) speed can be set to improve production. If bags are prematurely breaking at the perforation, reduce the index speed. For shorter bags, the speed can be significantly decreased (to 10"/Sec, for instance). The typical setting is between 15 and 25" per second.

H. Seal Temperature

Electrical current is pulsed to the heater element to maintain a constant temperature. Waiting LED is displayed if the temperature is not within the set range. The typical temperature setting is between 360°F and 440°F (182°C to 226°C) depending on film thickness.

3.8 Options Menu

Options that have been added to the T-1000 at the factory can be setup from the Options Screen. If options were not installed at the factory, then N/A (Not available) will be displayed to the left of each options button. Otherwise, the button will display ON or OFF. See Figure 3 - 5 and Figure 3 - 6.

Note: If options are added in the field, a pass code is required to enable use of the option. Contact APPI for pass codes. Options which have been purchased separately must be installed by Specialized Maintenance Personnel.

Note: Valve # X indicates the Valve Station number assigned to this option. Valve #0 indicates that no valve is assigned to this option. The option will not operate unless a Valve Station number is assigned, greater than 0.

The following sections describe the settings for optional equipment. If your T-1000 is not equipped with these options, please disregard these sections. Most of the listed options are not standard and must be purchased separately. Setting changes require testing prior to beginning production.

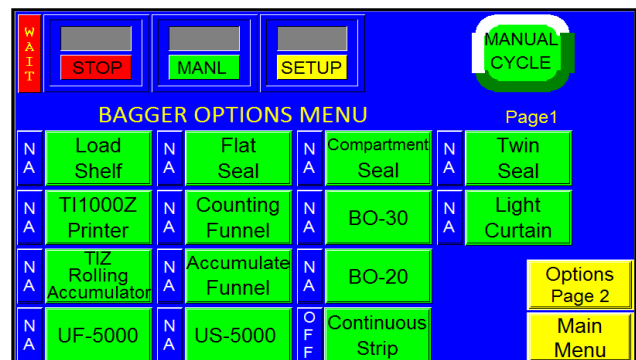

Figure 3 - 5

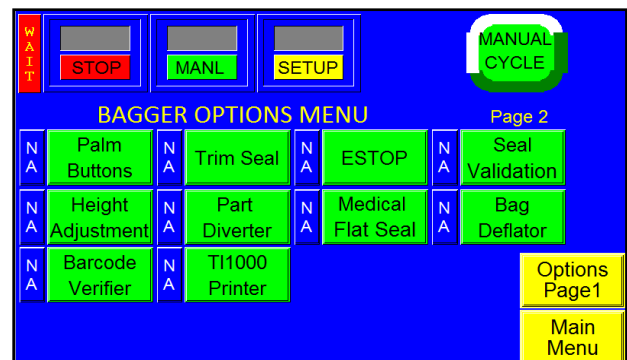

Figure 3 - 6

Due to specialized nature of some options or if your machine has custom programming, settings descriptions may not be included in this manual. Please contact Advanced Poly for special instructions.

3.9 LS-10 Load Shelf

This option is used as a support shelf for the product to avoid the bag from prematurely tearing off at the perforation when the product is inserted in the bag. The Load Shelf allows the product to drop onto the shelf relieving the pressure on the bottom of the bag. See Figure 3 - 7.

To turn ON the load shelf, press the <Load Shelf> menu option and press the <ON> button. The Load Shelf down time is the length of time the shelf is in the down position.

Note: Increase time for longer bags.

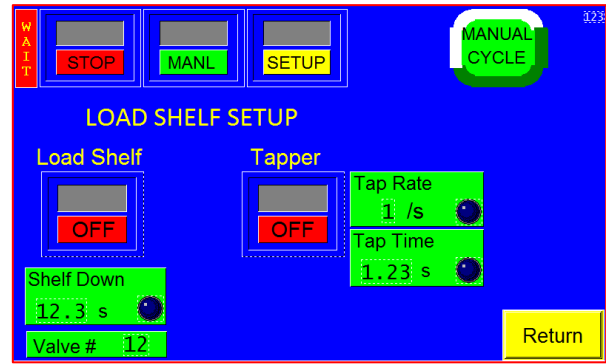

Figure 3 - 7

3.10 FS-10 Flat Seal Assembly

Fingers enter the bag immediately before sealing to pull the front/back layer of bag together, decreasing wrinkles or folds. Figure 3 - 8.

To turn the Flat Seal Assembly ON, press the <Flat Seal> button on the Options menu and toggle ON the ON/OFF button. Use the <Setup> button to make it easier to mechanically adjust the fingers along the front plate slots on the T-1000. Once the mechanical adjustment is complete, press <ON> and <AUTO> for normal operation of the flat seal assembly. In the Auto mode, the option will operate automatically.

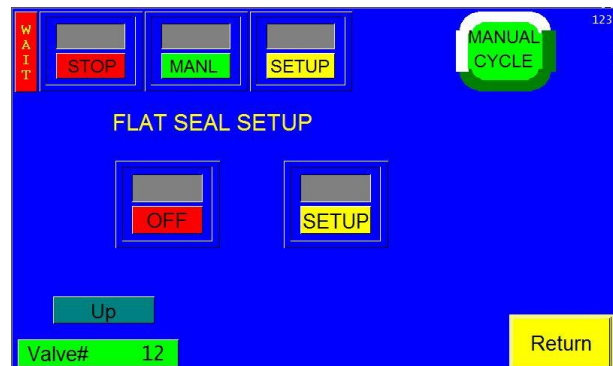

Figure 3 - 8

3.11 FS-30 Heavy-Duty Flat Seal Assembly

There are two separate motions:

1. Fingers enter the bag and start to pull the sides of the bag outward
2. Both fingers extend sideways with regulated pressure to pull the sides outward, further decreasing the opportunity for folds or wrinkles in the seal area.

In Setup Mode, the button operations are:

- <OFF> Position: Fingers Up and Out
- <SETUP> Position: Fingers Down and Out
- <HOME> Position: Fingers Down and In

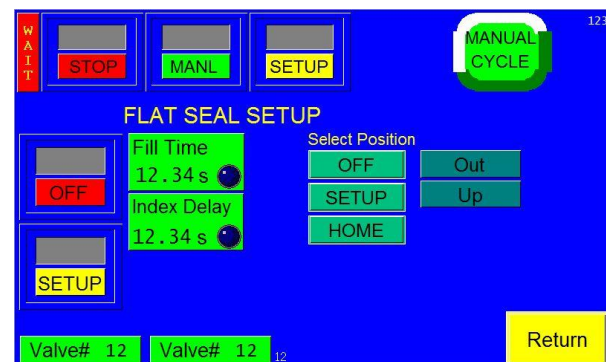

Figure 3 - 9

During Seal Cycle, fingers go to the “OFF” position when Seal Time starts, and before Index. This is to prevent fingers from interfering with next bag moving forward. See Figure 3 - 9.

3.12 CS-10 Compartment Seal

Seal the bag a second time to create a separate compartment in the bag. This option is useful to segregate different parts or protect damage caused from part contact. See Figure 3 - 10.

To start, set the First Seal Point by pressing the <Seal Point> button and typing in the value on the number keypad. Adjust the first seal point until the desired location is achieved. Next, turn the option ON by toggling ON the <ON> / <OFF> button. Then, adjust the second seal point by pressing <2nd Seal> and entering a value in the number keypad. Adjust the value of the second seal point until the desired position is achieved. Larger parts should be loaded first, in the larger, lower compartment.

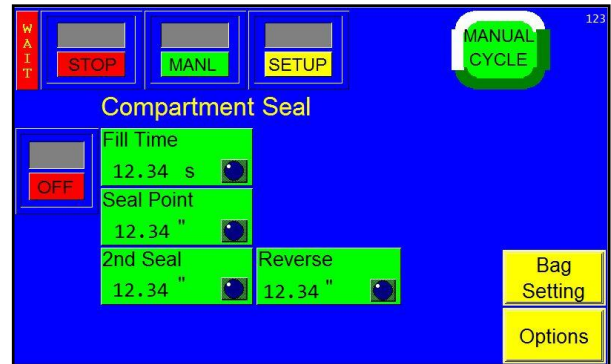

Figure 3 - 10

3.13 TS-10 Twin Seal Feature

Special programming is available to seal the bag twice, which increases the integrity of the bag. The Twin Seal setting can be adjusted on the Bagger Factory Settings screen. To turn on the Twin Seal option, press the <Twin Seal> menu option and press <Activate Option>, see Figure 3 - 11. The second seal should be very close to the first. If your machine does not include this feature, contact APPI for purchasing information.

Note: *The Seal Point value on the Bagger Settings Screen may need decreased to allow space for two seals on the same bag.*

Note: *Weight of the product, special load shelves or other options, funneling and bag size will affect the operation of this option. Contact APPI Sales Support for more information.*

3.14 Ti-1000Z Printer

To enable Printer operation on the Zebra Printer, press the <Activate Option> button, See Figure 3 - 12. If your bagger includes a printer, refer to the Ti-1000Z / Ti-1000ZRAP / T-1000-S14NB Printer Manual for further information regarding the operation of this option.

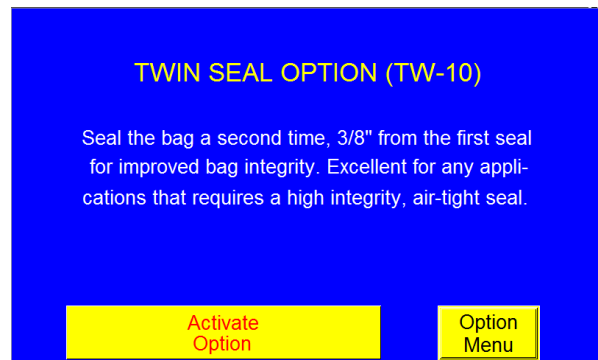

Figure 3 - 11

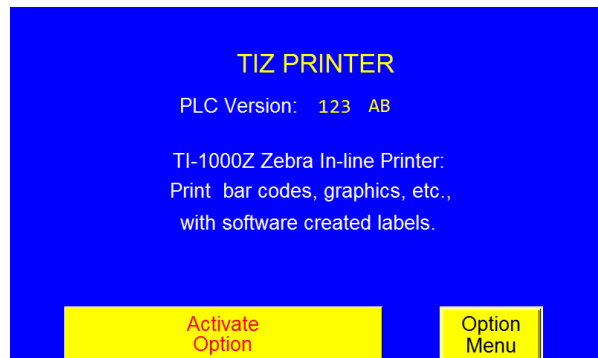

Figure 3 - 12

3.15 CF-10 Counting Funnel

This option is useful to automatically cycle the bagger when a preset number of parts have fallen through the funnel. See Figure 3 - 13. To turn ON the option, press the toggle button to ON. Press the <Reset> button to reset the count to the pre-set value.

Parts must have separation to be counted accurately through the eye. If two parts fall at the same time, they may be counted as one.

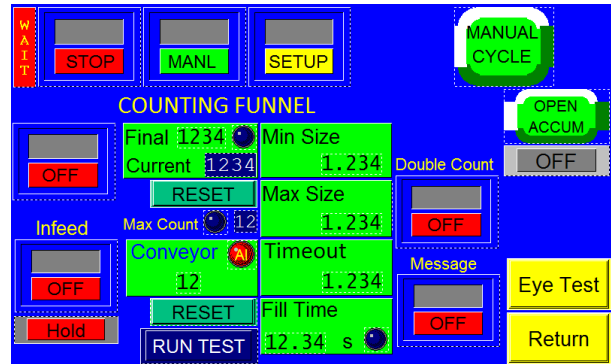

Figure 3 - 13

DOUBLE COUNT

Turning the Double Count feature **ON** will provide a more accurate count if two parts fall through the eye at the same time. The sensor will add a count if the maximum size is exceeded. Turning the Double Count **OFF**, the maximum setting is always zero. Turning **OFF** the Double Count feature may cause an over count of bagged product.

EYE TEST

Parts length test: (Eye Test) with the option ON, go to the Eye Test Screen and press the <Reset> button.

Press the <Stop> top mode button. Then, drop parts (samples) individually through the photo sensor / funnel. The Min and Max values will change as you drop parts through the eye. If parts will be fed automatically, parts should pass through the eye as they would if feeding automatically. See Figure 3 - 14.

Min and Max Settings and Time Out setting: These settings will be set automatically based on the “sample” parts values. Settings can be fine-tuned by manually entering the settings on the **Setup** screen.

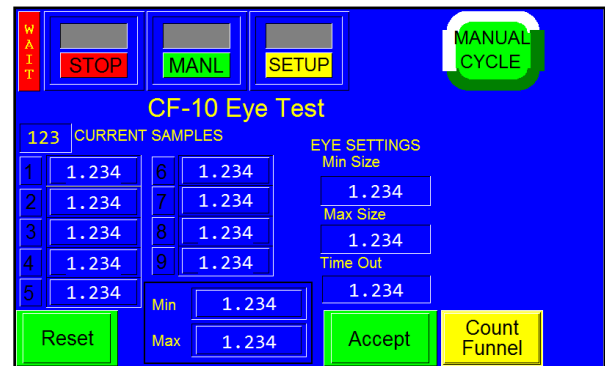

Figure 3 - 14

Press the <Accept> button after dropping many “sample” parts. If the Min / Max values continue to change, continue dropping samples until the values do not change. Then press the “Accept” button and return to the Counting Funnel screen.

Test by dropping one part at a time ensuring that the count increments by a value of one. If not counting correctly, return to the Eye Test screen, or change the Min / Max settings manually.

If the eye is blocked for an extended period of time (parts jam), the machine will stop and a message will be displayed.

3.16 BO-30 Bag Opening Device

This device enters the bag with one or more “fingers” and then pulls and holds the bag open. Air can also be shut off at this point. See Figure 3 - 15.

To turn ON this option, press the Toggle button to <ON>.

Down Delay is a delay time before the finger will attempt to enter the bag, after it is initially blown open. A typical value is 0.7 seconds.

Close Delay is the amount of time, in seconds, after the fingers have entered the bag before the fingers will pull the bag to the gripper point. A typical value is 0.5 seconds.

Ready Delay The amount of time, in seconds, it takes the fingers to cycle before the machine looks for an error.

Note: It is very important that Ready Delay is set correctly, as the entire operation of the machine is affected by this setting. If Ready Delay is too short, the machine could drop the product before it confirms the bag opening. The bag will not be ready and an error will occur. If Ready Delay is too long, the machine will cycle slower and there will be a loss of production.

Fill Time is the amount of time, in seconds, that an output will be sent to an auxiliary piece of equipment, after the bag has been opened and the opening validated. A typical value is 0.5 seconds.

Next Bag toggle button can be turned on to automatically reject an empty bag after failed attempts to open the bag. Bag will not be sealed if rejected by the bag open validation.

Blower During Loading toggle button turns off air if set to “OFF”.

BO Cycle button allows you to test cycle the Bag Opening Device alone, without initiating other equipment or the T-1000 seal operation.

3.17 LC-10 Light Curtain

This option is used as a safety device to disable air power when the active area is obstructed. See Figure 3 - 16 and Figure 3 - 17.

CAUTION: To avoid injury, do not reach under guards. This may defeat the safety feature of the LC-10 Light Curtain option.

As an additional safety function, the Automatic cycle mode is disabled when the Light Curtain option is turned ON.

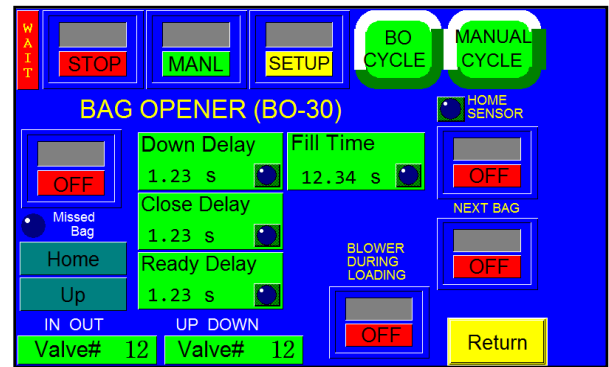

Figure 3 - 15

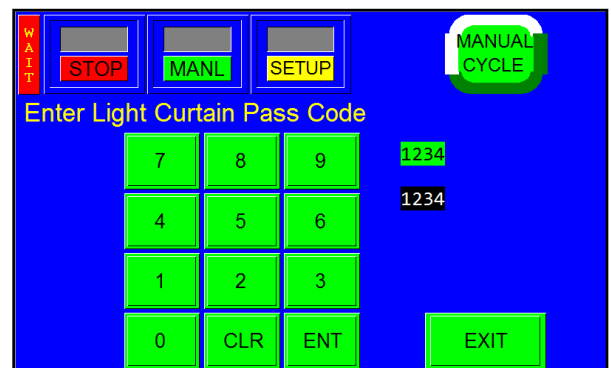

Figure 3 - 16

To enable the Light Curtain option, press the button labeled <Press to Enable>. Once enabled, you will not be able to disable the option without knowing the correct pass code. This prevents unauthorized personnel from enabling / disabling the option. Please refer to **3.38 Pass Code Setup Screen** for more information.

The Light Curtain option can be used as a means of initiating the cycle operation of the T-1000. To cycle the bagger automatically after the light curtain sensing area is cleared, press the <Mode> toggle button to change from Safe to Auto.

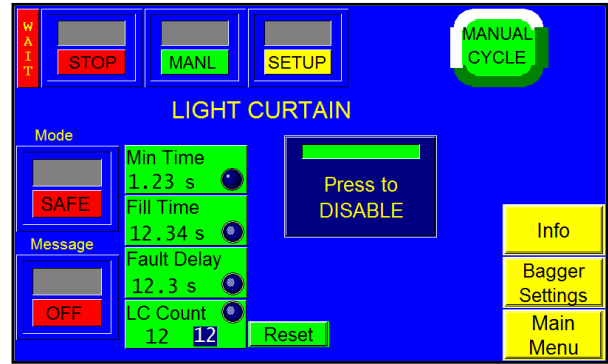

Figure 3 - 17

Message ON / OFF button: If this button is toggled to ON, a message is displayed every time the Light Curtain area is blocked. The message tells operators to check for an obstruction. See Figure 3 - 18. Remove the obstruction to continue operation. If this button is toggled to OFF, a message will not be displayed when the Light Curtain area is blocked.

Once in the Auto mode, the **Min Time** can be set to prevent starting a cycle until the light curtain area is obstructed for a longer period of time. A typical setting for Min Time is 0.5 seconds.

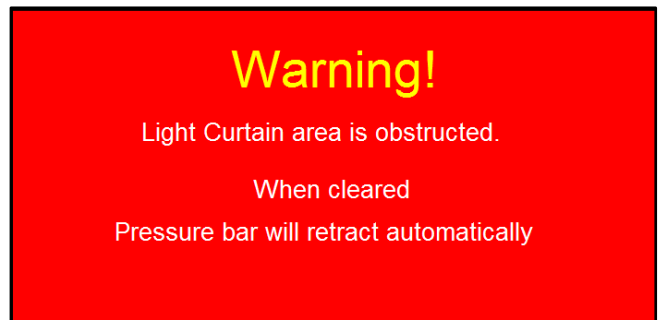

Figure 3 - 18

Fill Time: In Automatic mode, Fill Time is the amount of time, in seconds, before the machine cycles after the detection area is clear. For example, if the mode is set to Automatic and the Fill Time is set to one second, the machine will cycle only after the operator has removed his or her hands and after one second has elapsed. To set Fill Time, press the **Fill Time** button, enter a value using the numeric keypad and then press the **ENT** button.

Fault Delay: The amount of time, in seconds, the Light Curtain can be blocked before a warning message is displayed and machine operation is stopped. For operation to continue after a blockage occurs, the Light Curtain must either be unblocked or deactivated. To set Fault Delay, press the **Fault Delay** button, enter a value using the numeric keypad and then press the **ENT** button.

LC Count: a function that counts how many times the Light Curtain beam has been broken before the bagger will cycle. For example, if there are three parts that need to be entered into the bag individually, set the **LC Count** to 3. The bagger will cycle once the beam has been broken for the third time.

To deactivate the light curtain to install a funnel, press the button labeled <Press to Disable>. A keypad will be displayed which will require a special code. Unless you know this code, you cannot deactivate the light curtain option. Contact APPI Service Dept. for the pass code to disable the option.

3.18 BO-20 Bag Open Detector

This photo optic, closed contact sensor detects the opening or presence of bag material. This option will detect whether or not a bag is blown open or whether or not a funnel is inserted into the bag for validation that the bag is ready to receive product. The Bag Open Detector is valuable for an automatic operation to decrease the chance of product falling on the floor. To turn this option on, toggle the **ON / OFF** button to ON. See Figure 3 - 19.

The Bag Open Detector screen features two LEDs:

- **Blocked:** Illuminates when the sensor detects a blockage.
- **Latched:** Illuminates to indicate the sensor detected the bagger is latched.

Detect Time: The time allotted for the sensor to detect the bag before stopping the machine.

Min Time: The minimum amount of time, in seconds, the sensor has to detect the bag. A message will be displayed if the bag fails to open.

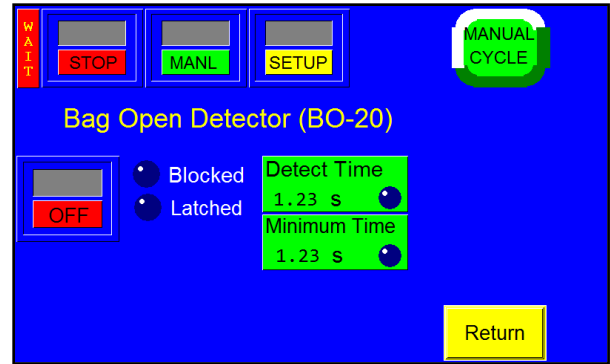

Figure 3 - 19

3.19 TIZ RAP / Accumulator

This hang-behind printer option is equipped with a festoon to collect bags that have already been printed on as they wait to go through the bagger. If this option is included on your machine, please refer to the Ti-1000Z / Ti-1000RAP / T-1000-S14NBO Printer Manual for more details.

3.20 AF-10 Accumulating Funnel

This special purpose funnel has several functions: 1) to accumulate a product before dropping the full contents of the Accumulator into the bag, 2) to contain a product while the equipment is sealing, 3) to insert the funnel into the bag and keep the product away from the sealing portion of the bag, and 4) to physically open the bag with a gate that enters into the bag while the product exits the funnel. See Figure 3 - 20 and Figure 3 - 21.

The funnel can be operated in an "Open Accumulator" mode or a "Closed Accumulator" mode. In an Open Accumulator mode, the door is closed only during the sealing operation. The door opens when the bag is in position and will remain open until the bag has been filled. The door will then close only until the next bag is in position.

In the Closed Accumulator mode, the door remains closed until the full batch is in the funnel. Then the funnel door will open until all product drops from the funnel.

Settings are provided to delay opening or maintain the opening until product has passed through.

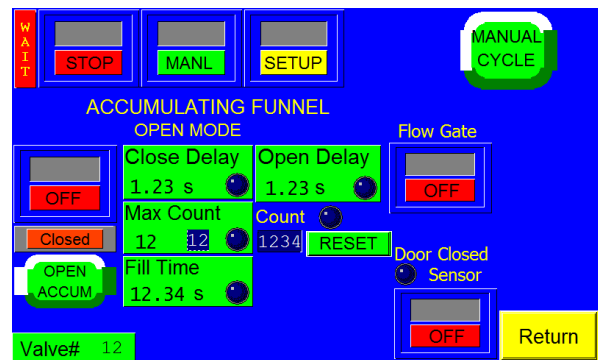

Figure 3 - 20

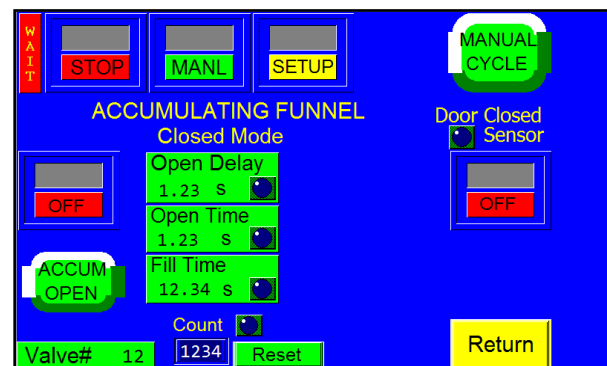

Figure 3 - 21

3.21 US-5000 / US-5500 Semiautomatic Net Weigh Scale

The US-5000 and US-5500 Net Weigh systems are versatile semiautomatic bagging systems which provides for fast bagging of kits or one type of part per bag, in counts up to 10,000 pieces.

If your company bags a wide variety of parts with multiple parts of various counts in bags, the US-5000 and US-5500 Kit Packaging systems are an excellent solution.

This option is accessed through the **Options** screen. A separate manual is provided if this option is purchased or is available upon request.

3.22 PB-20 Optical Palm Buttons

Palm Buttons can be used to cycle the machine instead of a foot switch. Two buttons, positioned on opposite sides on the machine must be *touched* simultaneously to cycle the bagger. If both buttons are not touched at the same time, or if one of the buttons is held while the other button is touched, the machine will not cycle. As an additional safety function, the Automatic cycle mode is disabled when the Palm Button option is turned ON. The foot switch input is also disabled when the Palm Button option is turned ON. See Figure 3 - 22.

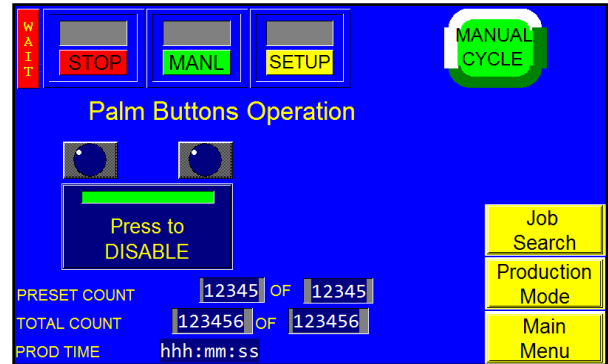

Figure 3 - 22

3.23 TS-10 Trim Seal Assembly

Trim Seal option removes excess film from the bag above the seal. See Figure 3 - 23.

Note: *To properly "trim-off" excess film, the bag length may have to be increased to provide the required finished bag size. We recommend trimming at least 1.25" of film from the bag.*

Press the <ON/OFF> toggle button to enable and disable the operation of the Trim Seal option. Seal Time, Seal Temp, Cool Time, Trim Del and Trim Time settings affect the operation of this option. Adjust the settings until bags are trimming consistently.

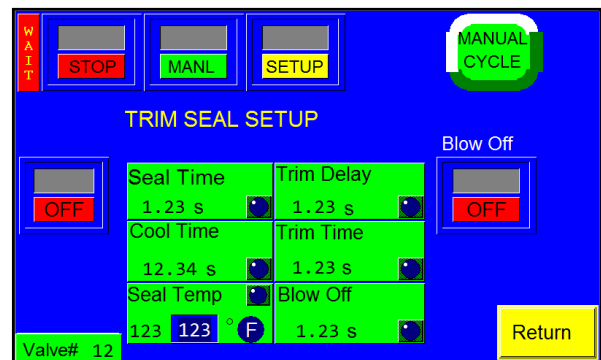

Figure 3 - 23

<Blow-Off > indicates the time which a blower will remove the excess film from the bag.

3.24 ES-10 E-Stop Circuit

This option can be used to stop the cycle operation of the T-1000 and possibly other auxiliary infeed or out-feed equipment. One or more Estop buttons may be equipped.

If depressed, the Estop button will cut power to the drive motors, turn off air pressure or otherwise halt moving components within the system. However, due to the wide range of equipment options, E-stops may function differently from one system to another depending on the components and safety requirements requested. When the Estop is pressed, a message screen will be displayed.

3.25 Adjustable Stand Screen

Operating height can be adjusted through the touch screen controlling a telescopic lift screw mechanism. To adjust the height, toggle the Option ON and press the UP Arrow or the DOWN Arrow. See Figure 3 - 24.

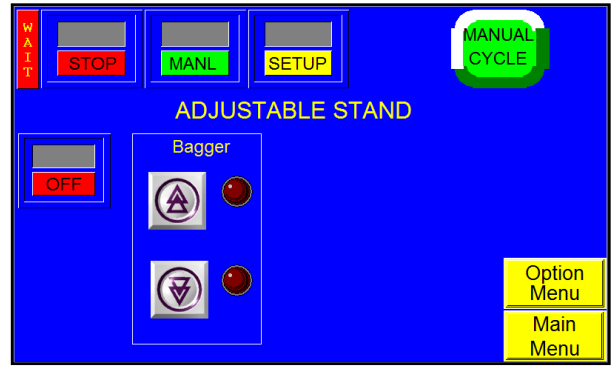

Figure 3 - 24

3.26 DF-20 Part Diverter (Diverting Funnel)

This feature is used to count bags and divert them from the bagger for further packaging operations. See Figure 3 - 25.

Final / Current: Final displays the total, preset count. Current displays the count the machine is processing. Press the green <Final / Current> button, enter a value on the numeric keypad and press the <ENT> button to adjust the final count. The Final LED will illuminate when the final count is reached. Press the <Reset> button to reset the Final Count.

Flip Delay: The amount of time, in seconds, before the part diverter will flip after receiving a signal from the sensor.

Note: Valve # X indicates the Valve Station number assigned to this option. Valve #0 indicates that no valve is assigned to this option. The option will not operate unless a Valve Station number greater than zero is assigned.

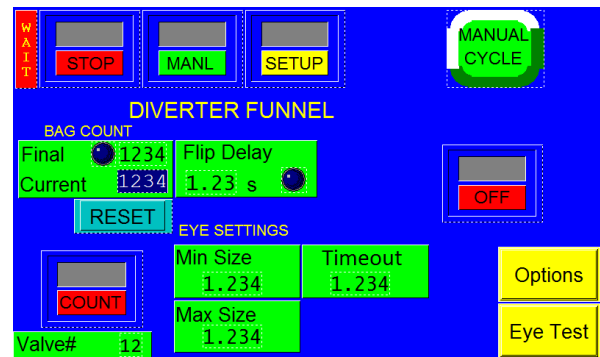

Figure 3 - 25

Min Size: This setting affects how parts are counted and is used to filter scrap. Min Size can either be manually set by the operator or automatically set after an eye test is performed. If manually set, Min Size should be set to reflect the minimum size that can be counted as one part. For example, if the Min Size is set to 0.4, a part measured at 0.3 would not be counted, while a part measured at 0.5 would be counted as one part (assuming 0.5 falls below the Max Size setting). If automatically calculated, Min Size is 80% of the Min measurement. To adjust Min Size manually, press the <Min Size> button, enter a value on the numeric keypad and press the <ENT> button.

Max Size: This setting affects how parts are counted and is used to count connected parts or parts falling through the eye together as two parts. Max Size can either be manually set by the operator or automatically set after an eye test is performed. If manually set, Max Size should be set to reflect the maximum size that can be counted as one part. For example, if the Max Size is set to 0.8, a part measured at 0.6 would be counted as one part (assuming 0.6 is above the Min Size setting), while a part measured at 0.9 would be counted as two parts. If automatically calculated, Max Size is 160% of the max measurement. To adjust Max Size manually, press the <Max Size> button, enter a value on the numeric keypad and press the <ENT> button.

Note: If Min Size is set too close to the actual minimum test value, some parts may not be counted, causing overcounts. If Max Size is set too close to actual maximum test value, one part may be counted as two, causing undercounts.

Timeout: The length of the time (time-out time) the eye does not take a measurement while reading a part. Press the <Timeout> button, enter a value on the numeric keypad, and press the <ENT> button to adjust the value.

Eye / Count Toggle button: When toggled to COUNT, the diverter flips to divert bags after a preset quantity have been cycled. When toggled to EYE, the diverter flips and diverts every bag.

To ensure the accuracy of the count, an eye test must be performed. Press the <Eye Test> button to display the DF-20 Eye Test screen and perform an eye test.

Parts Length Test (Eye Test): With the Part Diverter option turned on, press the **Reset** button on the Eye Test screen, See Figure 3 - 26. Toggle the <START / STOP> toggle button to <STOP>. Then, drop parts (samples) individually through the photo sensor / funnel. The Min and Max values at the bottom of the screen will change as parts are dropped through the eye. If parts will be fed automatically, parts should pass through the eye as they would if feeding automatically.

Note: While the Eye Test screen only displays the last nine-part readings, there is no limit to the number of parts that can be used during an eye test.

Min: The smallest size recorded during a test.

Max: The largest size recorded during a test.

Time Out: This setting is automatically calculated based on the “sample” parts values and the eye test results. Time Out displays the period of time the eye does not take a measurement while reading a part.

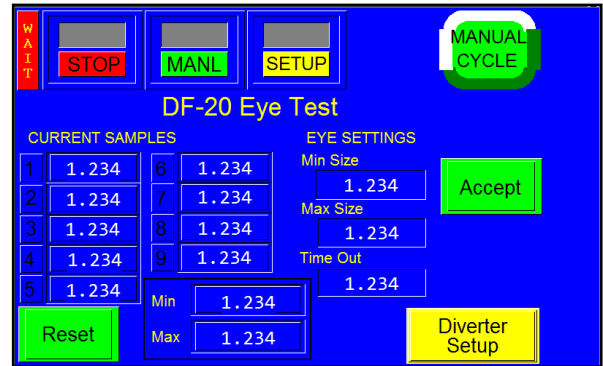

Figure 3 - 26

Press the <Accept> button if the Min / Max values do not change after dropping many sample parts. If the Min / Max values continue to change, continue dropping samples until the values do not change. Once the values remain consistent, press the <Accept> button and return to the Counting Funnel screen.

Test the settings by dropping one part at a time, ensuring that each count is a value of one. If not counting correctly, return to the Eye Test screen or change the Min / Max settings manually. If the eye is blocked for an extended period of time (parts jam), the machine will stop and a message will be displayed.

3.27 MV-20 Seal Validation

The Seal Validation option is not included in the standard T-1000 package and must be purchased separately. APPI provided additional components to provide a secondary means detecting a failure or out of range condition for components that affect seal quality. See Figure 3 - 27.

To cause a good seal and to confirm that each component required to obtain the seal is in range, we have added three validations to the T-1000:

1. Seal Temperature: a secondary controller was added with an alarm output that alarms when the temperature falls out of the set range in the temperature controller.

2. Seal Time: sensors on the seal bar measure how long the seal bar is engaged to validate that the heater bar is extended within an acceptable time compared to the set seal time. Seal Time is measured by the PLC for how long the 'Seal Bar In' sensor is activated. Cool Time is when the Pressure bar holds the bag in place without the Heater

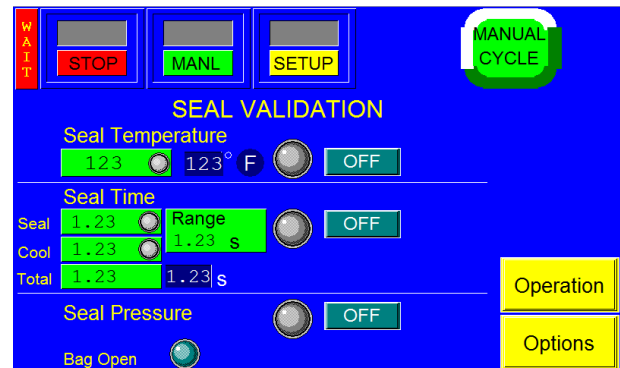

Figure 3 - 27

Bar applying heat. If 'Cool Time' is used, Total Time is 'Seal Time' plus 'Cool Time'. Add 'Total Time' on 'Seal Validation' screen and use it for validation.

Range: When the range is set, it allows a variance (+/- seconds) from the set seal time.

3. Seal Pressure: a pressure sensor was added with an alarm output that alarms when the pressure falls out of the set range in the pressure sensor.

Typically, medical companies require seal validation as a secondary means to detect out of range conditions are to stop the operation when the condition exists. A Message will be displayed if any of the three validation components are out of range. The Pressure Sensor may also be added to the T-1000 to validate only pressure, without adding the other two components. For application requiring this validation only, the bagger will not operate unless the sensor provides an output indicated that the pressure is above a minimum allowable setting.

3.28 Medical Flat Seal

This flat seal option has added Fill Time and Seal Delay functions to adhere to medical specifications. See Figure 3 - 28.

On / Off turns the feature on or off.

<In / Up> changes to <Out / Down> depending on the position of the fingers.

Fill Time: The amount of time, in seconds, before the bagger begins to seal the bag after the accumulating funnel door has closed.

Seal Delay: The amount of time, in seconds, before the seal operation begins after the air is turned off. This delay setting allows air to escape the bag. To change this setting, press the <Seal Delay> button, enter a value on the numeric keypad and press the <ENT> button.

FSEAL CYCLE: Cycles the flat seal fingers.

Cancel: Pressing <Cancel> will reset the cycle.

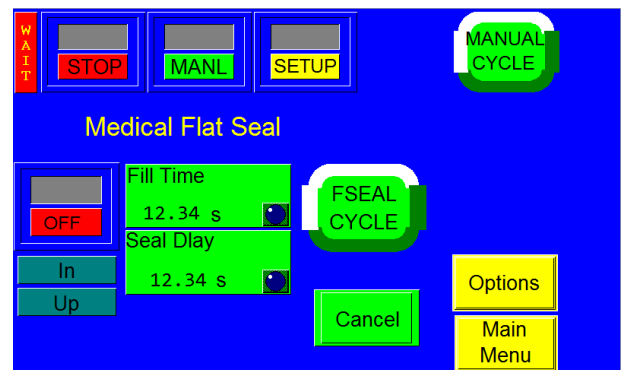

Figure 3 - 28

3.29 BF-10 Bag Deflator

To press the air from the bag, a pneumatic bag deflator can be fitted. Several timers are provided to change the sequence of operation. Toggle the option ON and adjust the Seal Delay settings to cause the bag deflator to cycle prior to the seal bar. See Figure 3 - 29.

Fill Time: The amount of time, in seconds, before the bagger begins to seal the bag after the accumulating funnel door has closed.

Seal Delay: The amount of time, in seconds, before the seal operation begins after the air is turned off. This delay setting allows air to escape the bag. To change this setting, press the <Seal Delay> button, enter a value on the numeric keypad and press the <ENT> button.

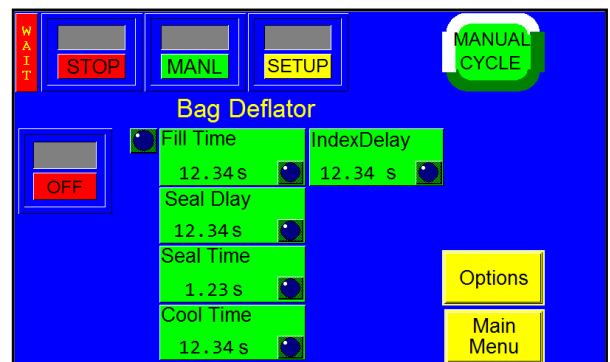

Figure 3 - 29

Seal Time: The amount of time, in seconds, the heater bar will remain touching the surface of the bag for proper sealing. To adjust this setting, press the <Seal Time> button, enter a value on the numeric keypad and then press the <ENT> button.

Cool Time: The amount of time, in seconds, the pressure bar is released to ensure the seal is cool enough to be torn off after the pressure bar and heater bar have come in contact with the bag. To adjust this setting, press the <Cool Time> button, enter a value on the numeric keypad and then press the <ENT> button.

Note: The Seal Time and Cool Time work in conjunction with one another. The Cool Time cannot be set lower than the Seal Time. For Example, if the Seal Time is set for 0.5, the Cool Time cannot be set lower than 0.5.

Index Delay: The amount of time, in seconds, the previous bag has to exit the seal area after it is released and the next bag is fed into place. This delay prevents the next bag from feeding and prevents the seal bar from coming into contact with the previous bag and causing a bag jam. To change this setting, press the <Index Delay> button, enter a value on the numeric keypad and press the <ENT> button.

3.30 UF-5000 Infeed Conveyor Operation Screen

The UF-5000 is an optional conveyor available for purchase. If your machine or system includes a conveyor please refer to the UF-5000 manual for further information.

3.31 BV-10 Barcode Verification Option

This option is purchased to validate that a barcode is present and readable. See Figure 3 - 30.

Press the <ON> toggle button. For each barcode successfully read, the status box will provide a “GOOD” message. If a “NO READ” or “QUALITY” error occurs, a message will be displayed. To reduce these error messages, APPI recommends scanning the barcode before the bag is blown open when the film is flat and under tension (not past the feed rollers.)

TEST: The Test button will test read a printed label. Testing the printed label will ensure the bagger and Barcode Verifier are calibrated correctly.

Reprint: The Reprint Toggle button can be used to reprint the previous label if the Barcode Verifier did not read. If Reprint is turned **ON**, and the verifier records a “NO READ” error, the barcode verifier will automatically rescan the label. If the bagger records “NO READ” after the rescan, the next bag is indexed with the same label printed a second time. If the T-1000-S14 is running in Manual Mode, a warning screen will be displayed, and the operator will have the option to reprint the label from that screen.

Quality Error: A STOP/CONTINUE toggle button to manage a “POOR QUALITY” read. When <CONTINUE> is toggled, the “POOR QUALITY” reading will be ignored. When <STOP> is selected, the same sequence for the Next Bag Reprint will be enabled.

Blower: Turns off the blower while setting up the Barcode Verifier.

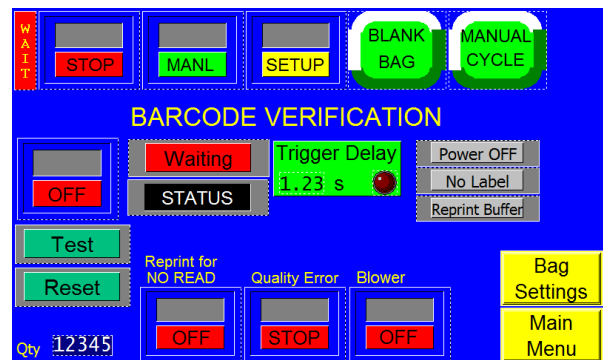

Figure 3 - 30

3.32 Ti-1000 Inline Printer

The Thermal Inline Transfer Printer - prints text, graphics and bar codes, formatted in a separate software program. The label formats are "downloaded" to the printer from a PC.

To enable Printer operation on the Thermal Transfer (TT) Printer, press the highlighted <Printer Ti-1000> button.

Toggle <ON> to enable operation of the printer. See Figure 3 - 31.

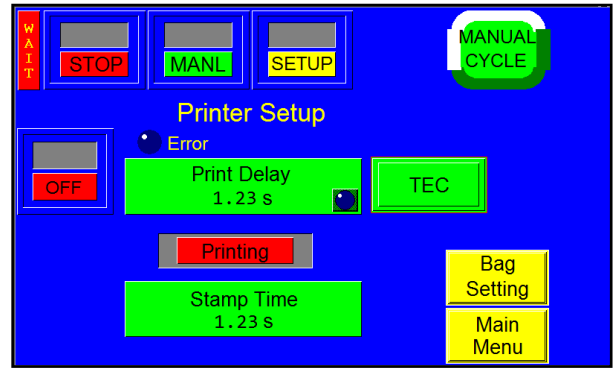

Figure 3 - 31

3.33 Counters Screen

Two internal counters are provided as a standard feature. To access the counter screen, press the <Counter> button from the Main Menu. See Figure 3 - 32.

Totalizing Counter: To track production, use the Totalizing Counter to count cycle operations of the machine. Press the <Reset> button to reset the counter to zero. This counter value is also displayed on the Operation Screen.

Preset Counter: To halt production after a preset number of cycle operations, use the Predetermining Counter. When the final count has been reached, a message screen will be displayed.

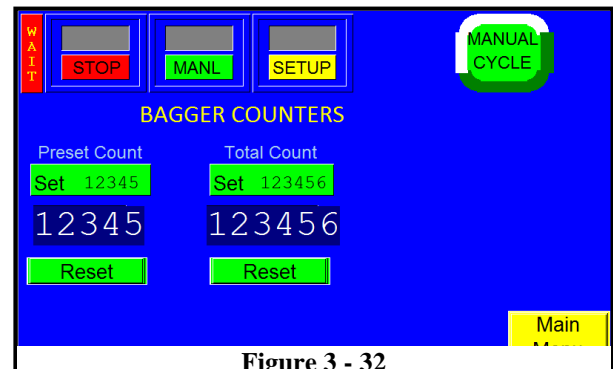

Figure 3 - 32

Set the value by pressing the <Set> button and then type the value on the number keypad followed by the <Enter> button. To disable the Predetermining Counter set the value to "0".

3.34 Continuous Strip Screen

Continuous Strip Counter: This option allows you to seal bags in a strip, without separating them at the perforation. If you set this counter value to 10, for instance, you will have a strip of 10 bags connected. The bagger will then reverse to separate the 11th bag. See Figure 3 - 33.

Press the <Reset> button to reset the counter to the set value. To disable the option, set the value to zero.

Note: If you don't want the bags separated ever, you can either set the counter value to very large number or simply change the Reverse setting to zero in the Bag Setup Menu.

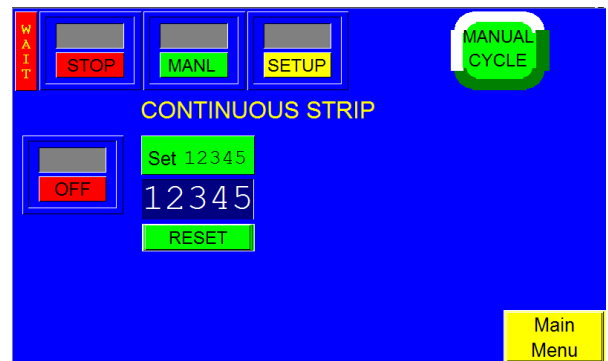

Figure 3 - 33

3.35 Temperature Calibration Screen

This calibrated temperature screen will allow for temperature calibration of the heater bar. A typical temperature setting is 400°F or 204°C. The maximum temperature setting is 600°F or 260°C. The operator will have the option of choosing between two thermocouples (TC 1 and TC 2). Since variables such as position and age of the thermocouples may affect the actual reading, a calibrated readout will provide for more consistency in sealing. See Figure 3 - 34.

To access the **Temperature Calibration** Screen, from the **Main Menu** press **Technical Assistance** (this requires a level 1 Passcode), press **Bagger Factory** and press the yellow **Temperature Calibration** button along the right side of the screen (See Figure 3 - 40).

Measured Temperature: Displays the current temperature of both thermocouples, for example, 400°F (or C equivalent).

Adjustment: An entry field to enter an adjusted temperature. If there is an outside source to read the temperature of the heater bar and there is a variance between the bagger and the outside source temperature gauge, the <Adjustment> button allows for that variance to be accounted for. For example, if the outside calibration equipment reads 403°F and the bagger shows 400°F, a value of -3° can be entered into Adjustment, allowing the variation to be known. By pressing the green button, a numeric keypad is accessed where two digits, negative or positive can be entered into this field.

Read Out: Combines the Current Temperature and Adjustment then displays the calculated adjusted temperature, in the case of the above example, 397°F.

Control Mode (Read): Standard temperature control by a single thermocouple.

Control Mode (Compare): Dual Temperature control, both readings have to be within the Compare Range, set on the screen by the operator. If either thermocouple exceeds the Compare Range, an alarm is displayed and the Heater Bar shuts down.

Heater LED: Duplicates the indicator on the **Bagger Settings Screen** (See Settings Screen 3.7), and shows the status of the Heater:

- Green indicates Heater is functioning correctly.
- Red indicates a fault condition.

The Heater status is monitored for two conditions:

- Fast Heating – Temperature must increase by 10° F over threshold within 60 seconds
- Temperature Maintenance – Temperature is monitored every 10 seconds for sudden variations over a 30 second interval.

If either of these conditions occur, a fault condition is triggered, and the Heater will be disabled until the <Reset> button is pressed.

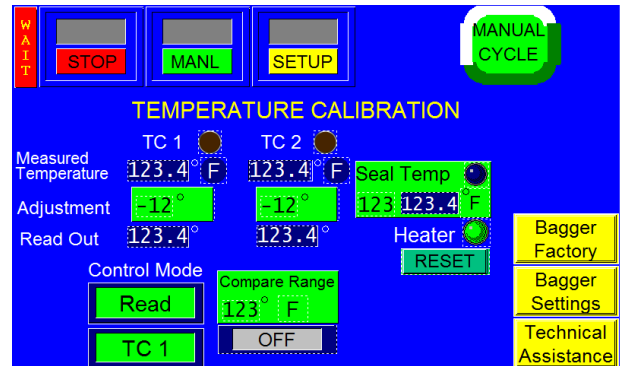

Figure 3 - 34

3.36 Technical Assistance & Troubleshooting Screens

Technical assistance sections of the Touch Screen program should be accessed by Specialized Personnel only and are provided for troubleshooting and advanced setup by Qualified Service Engineers.

The Technical Assistance screen provides manufacturer information, factory settings adjustments and functions testing and troubleshooting. It also displays program version for PLC controller and touch screen. See Figure 3 - 35.



Figure 3 - 35

The screen is protected from access with a Level 1 pass code. The pass code is set by default (from the factory) to 1001. See Figure 3 - 37. This code can and should be changed when the system is put into operation. See section 3.37 for “Pass Code Setup”.

Several menu options are available from the Tech Assist. Menu which will assist with troubleshooting the T-1000-S14 and change settings that affect the operation of the equipment.

3.37 Bagger Auxiliary Options

Auxiliary communication is provided by closed contact signaling. Additional cabling may be required which will transfer the signals between the machines in the system. See Figure 3 - 36.

Auxiliary settings are displayed on this screen but must be change in the Technical Assistance / Aux Setup screen.

The auxiliary signal mode will depend on the type of equipment connected.

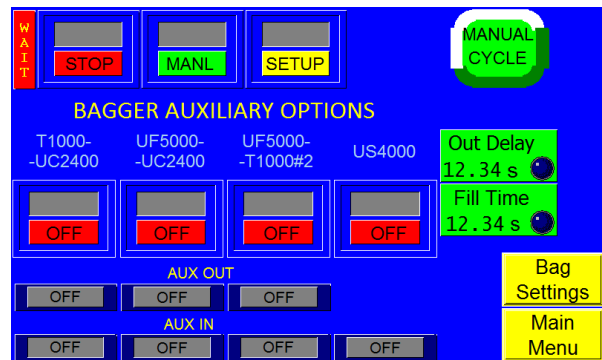

Figure 3 - 36

3.38 Pass Code Setup Screen

Advanced Poly-Packaging, Inc. (APPI) has included a pass code function in all touch screen equipment to prevent operators from changing settings.

There are two pass code levels described as follows:

1. Level 1: This is the highest-level pass code which prevents operators from accessing the Technical Assistance functions of the machine. The default pass code, when shipped from the factory, is 1001. See Figure 3 - 37.

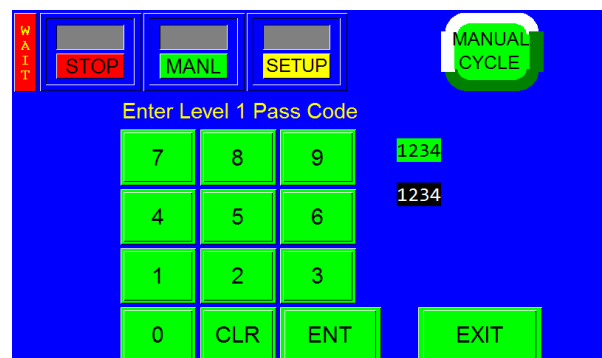

Figure 3 - 37

- Level 2: This level pass code, when the pass code function is enabled, prevents the operator from accessing settings screens that affect the operation of the equipment. See Figure 3 - 38.

Pass codes prevent unauthorized individuals from tampering with settings. When equipment is shipped, APPI uses the following codes which should be changed prior to putting the T-1000 into operation. Factory Set Pass Codes:

- Level 1 pass code: 1001
- Level 2 pass code: 1002

To enable the pass code function, press the <Tech Assist> button from the Main Menu. Type in the Level 1 pass code (1001 by default from APPI). Press <Bagger PassCode> from the **Tech Assist** screen, then press <ON> to toggle the pass code function ON. See Figure 3 - 39. Once the pass code function is enabled, the operator will have a programmed amount of time (time-out time) to make changes. Once this time has elapsed, the Operation Screen will automatically be displayed. This time can be changed by accessing the Bagger Password Setup Screen, pressing <PW Timeout> and entering the new value on the green numeric keypad. Press <Enter> to confirm, <CLR> to clear the value and <Exit> to cancel. To Change the password Press either <Level 1 PW> or <Level 2 PW> depending on which code you would like to change. This will access a green numeric keypad where the current pass code will be displayed in the box to the right. Type in the new pass code and press <ENT> to confirm.

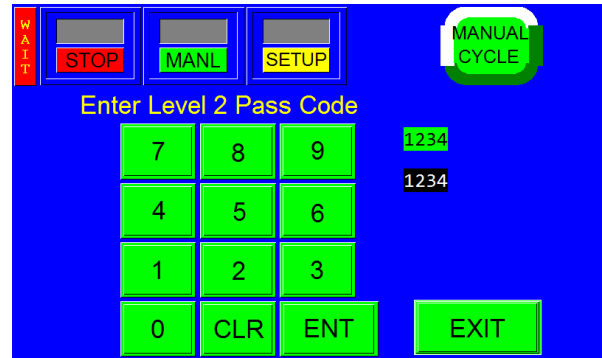

Figure 3 - 38

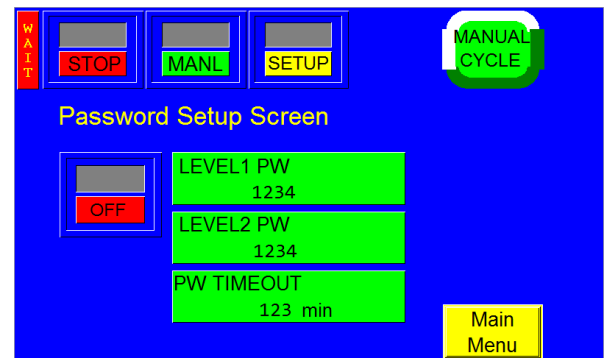

Figure 3 - 39

Note: If you change the pass codes, ensure that these codes are written down.

If you misplace or forget the pass codes, contact APPI Service Dept. for assistance. APPI will provide a “factory code” so that the current pass codes can be displayed. Once you receive the factory code, put the bagger in ‘STOP’ mode, press 'MANUAL CYCLE' three times to open 'Password Setup' screen. From there, enter the factory code and your current pass codes will be displayed.

3.39 Bagger Factory Settings

This screen can be accessed through the **Tech Assist** screen and contains additional bagger settings, including Brightness Control, that should only be set by qualified technicians or by the factory. See Figure 3 - 40.

Heat Off: The amount of time, in minutes, the machine can remain inactive before the heater bar will automatically turn off. The machine will remain on even if the heat is off. To adjust this setting, press the **Heat Off** button on the Bagger Factory Settings screen, enter a value on the numeric keypad, and press the <ENT> button.

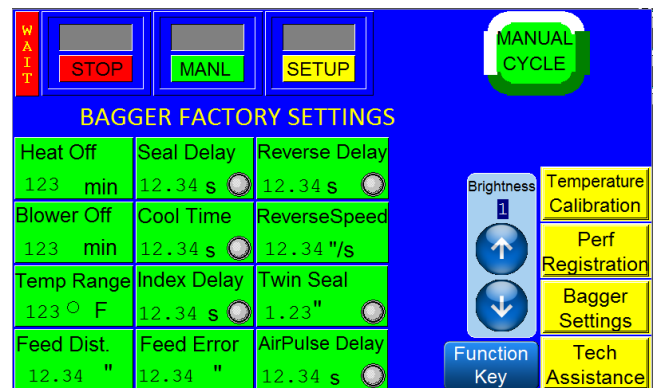

Figure 3 - 40

Blower OFF: To preserve compressed air, the blower (air knife) will turn off after this preset amount of time has passed. The value is set in minutes and fractions of a minute. For instance, a setting of 5.1 would turn the air off if the machine is not in use for a period of five minutes and six seconds. A typical value is between three and five minutes.

TempRange: The temperature range above and below the Seal Temperature set point the heater bar must reach for the T-1000-S14 to operate fully. For example, if the Seal Temperature is set to 360°F(182.2°C) and the Temp Range is set to 10° , the temperature would be within the acceptable range if the heater bar temperature was between 350°F and 370°F (176.6°C and 187.7°C). If the temperature is within the acceptable range, the bagger will display “Ready” and the T-1000-S14 can begin normal operation. If the temperature is out of this range, the bagger will display “Waiting” and the T-1000-S14 will only be able to cycle in Setup mode. To change this setting, press the <Temp Range> button, enter a value on the numeric keypad and press the <ENT> button. A suggested setting for Temperature Range is 20°.

Feed Dist: The bag length distance, in inches, the perforation sensor does not look for a perforation in the bag when the machine is indexing the bag. To change this setting, press the <Feed Dist> button, enter a value on the numeric keypad and press the <ENT> button.

Seal Delay: The amount of time, in seconds, before the seal operation begins after the air is turned off. This delay setting allows air to escape the bag. To change this setting, press the <Seal Delay> button, enter a value on the numeric keypad and press the <ENT> button.

Cool Time: The amount of time, in seconds, the pressure bar is released to ensure the seal is cool enough to be torn off after the pressure bar and heater bar have come in contact with the bag. To adjust this setting, press the <Cool Time> button, enter a value on the numeric keypad and then press the <ENT> button.

IndexDelay: The amount of time, in seconds, the previous bag has to exit the seal area after it is released and the next bag is fed into place. This delay prevents the next bag from feeding and prevents the seal bar from coming into contact with the previous bag and causing a bag jam. To change this setting, press the <Index Delay> button, enter a value on the numeric keypad and press the <ENT> button.

Feed Error: The amount of acceptable variation, in inches, from the set bag length. For example, if the bag length is 15" and the Feed Error is set to 3", bags with 12-18" lengths would be accepted, but bags with a length of 19" would cause operation to stop and an error message would be displayed. To change this setting, press the <Feed Error> button, enter a value on the numeric keypad and press the <ENT> button.

Reverse Delay: The amount of time, in seconds, after the bag has been filled and sealed before the bag is reversed. To change this setting, press the <Rev. Delay> button, enter a value on the numeric keypad and press the <ENT> button.

Reverse Speed: The speed, in inches per second, at which the bagger reverses to separate the bag at the perforation. To change this setting, press the <Reverse Speed> button, enter a value on the numeric keypad and press the <ENT> button.

Twin Seal: The pressure bar seals for the first time then reverses and seals the bag a second time, below the first seal. Press the green button to access the numeric keypad and set the distance between Twin Seals. A typical distance is ¼”.

Air Pulse Delay: The amount of time, in seconds, before the air pulse operation begins. This delay setting allows the bag to get into position before blowing it open. To change this setting, press the <Air Pulse Delay> button, enter a value on the numeric keypad and press the <ENT> button.

Brightness Control. UP & Down buttons set brightness to 4 different levels, with “1” being the brightest and “4” being the dimmest.

3.40 Bag Registration

The Bag Registration screen allows the operator to set up the perforation. See Figure 3 - 41.

To determine if the seal point is registered, set the Seal Point setting to the lowest possible setting. Then press the <Manl> cycle button or press the foot switch. The bag should move so that the perforation is approximately 1/8" from the center of the heater bar. If the bag perforation is not approximately 1/8" from the perforation, perform the following procedure carefully. If these steps are performed out of order, the bagger will not function properly.

Follow these steps to set up the perforation:

1. Press the <Perf Registration> button on the Bagger Factory Settings screen. The Bag Registration screen will be displayed.
2. Press the <Find Perf> button. The bagger will advance until the perforation sensor finds the perforation, and then the bag will stop.
3. Hold the <JOG+> button until the perforation moves down to the middle of the PTFE sheet area at the heater bar.
4. Release the <JOG+> button.
5. Push the <Zero Seal> button once.
6. Hold the <JOG-> button until the perforation moves up to just in front of the nip rollers.
7. Push the <Max Reverse> button once.

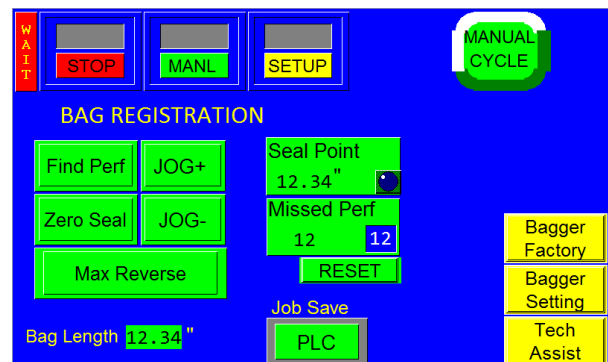

Figure 3 - 41

Note: If these steps are performed incorrectly, repeat from Step 1.

When complete, test the Seal Point setting by entering 0.1" and pressing the <Manual Cycle> button. The bag should feed so that the perforation is approximately 1/8" from the center of the heater bar.

Since the procedure set the maximum reverse value as well, enter 6" in the Max Reverse setting. If equipped with a standard frame bagger, this setting will be approximately 1.8" when the Seal Point setting is 0.1". On a drop frame machine, the maximum setting will be approximately 2.7" when the Seal Point setting is 0.1". Press the **Manual Cycle** button and ensure that the bag does not reverse too far, to drop inside the machine. After successfully performing the above steps, the Bag Registration screen is ready for bag indexing.

Missed Perf: The maximum number of perforations the sensor can miss before operation stops and an error message is displayed. To adjust this setting, press the <Missed Perf> button, enter the desired value on the numeric keypad and press the <ENT> button.

3.41 Job Save and Recipe Management

From the **Main Menu** touch <Technical Assist> and enter the Level 1 Pass Code. Touch the <Bagger Factory> button to access the Bagger Factory screen. From there touch the <Bag Registration> button located along the right-hand side of the screen. Once in the Bag Registration screen, locate the **Job Save toggle button** along the bottom of the screen, see Figure 3 - 41. If the toggle button reads “**PLC**” the machine will save all jobs internally on the PLC. If the button reads “**USB**” all jobs will be saved externally to a USB memory stick. Press the button to toggle between the two. Once you have made your selection exit back to the **Main Menu** by pressing the <Tech Assist> button and press <Exit> when the numeric keypad is accessed.

Note: *There must be a USB Flash Drive / Memory Stick inserted into the machine for the External Memory function to operate. If there is no memory stick inserted, ensure the Job Save is in PLC mode in order to save job recipes.*

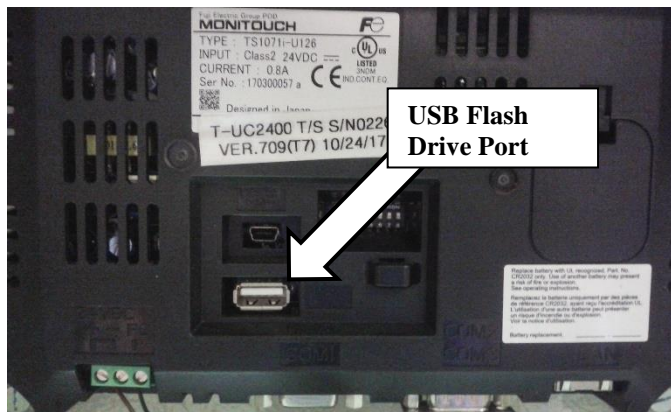

Figure 3 - 42

Note: *All units with a 7” Touch Screen should support Recipe Management; a Bagger without a Touch Screen will have only PLC Storage.*

There are benefits to using either memory option. The PLC Internal option, referred to as “Job Save”, allows the user to save up to 24 jobs to the PLC without any extra hardware required. The USB External option has the additional functionality of Recipe Management and allows the user to save an unlimited number of jobs to the USB memory stick as well as performance data. A file will be automatically created on the memory stick that contains Recipes, Alarm data, and Production data from the machine. These files can be viewed when the memory stick is inserted into a PC. Please refer to **3.42 “Memory Files and Data Structures”** for more information regarding the files and directory structure.

Note: *Remove the back cover of the touch screen housing to locate the USB port and insert a memory stick (not included). See Figure 3 - 42.*

Note: *These instructions are for saving Bagger settings only. Labels are saved using printer software (such as LabelView).*

A. Internal Memory (PLC)

Saving a job to Internal Memory: Select <PLC> in the Bag Registration screen (as described above) and exit to the **Main Menu**. Go to **Settings** and set the specifications for your job. Once the job is set, touch <Job Save> on the right side of the screen to access the **Bagger Job Save** screen, see Figure 3 - 43. Select the designation under PN where you would like to save the job (#1-24), which will access a green numeric keypad. Enter a numeric name for your job and touch <Ent>. A warning screen will ask if you would like to overwrite the job. The PN of the current job at that location will be displayed in a box to the side. This box will display “0” if it is not being used. Select <Yes> to overwrite and continue. Your job is now saved to the Internal Memory on the PLC.

No	PN	No	PN	No	PN	No	PN
1	123456	9	123456	17	123456		
2	123456	10	123456	18	123456		
3	123456	11	123456	19	123456		
4	123456	12	123456	20	123456		
5	123456	13	123456	21	123456		
6	123456	14	123456	22	123456		
7	123456	15	123456	23	123456		
8	123456	16	123456	24	123456		

CURRENT JOB
Line No: 12
PN: 123456

Main Menu

Figure 3 - 43

To recall a job from Internal Memory: Touch <Job Search> on the Main Menu to access the Touch to Recall screen, see Figure 3 - 44. The jobs that are saved to the PLC will be displayed in this table. Touch the job you would like to recall. This will take you to the Job Load screen that displays the settings for this job, see Figure 3 - 45. Ensure this is the correct job and touch <Load>. This will take you to the Bagger Settings screen with all the settings loaded and ready to start the job.

No	PN	No	PN	No	PN	No	PN
1	123456	9	123456	17	123456		
2	123456	10	123456	18	123456		
3	123456	11	123456	19	123456		
4	123456	12	123456	20	123456		
5	123456	13	123456	21	123456		
6	123456	14	123456	22	123456		
7	123456	15	123456	23	123456		
8	123456	16	123456	24	123456		

CURRENT JOB
Line No: 12
PN: 123456

Main Menu

Figure 3 - 44

Settings
For Part No: 123456

LOAD

Fill Time	12.34	Reverse Delay	12.34
Seal Time	12.34	Index Delay	12.34
Seal Point	12.34	AuxOut Delay	12.34
Air Pulse	12.34	Reverse Speed	12.34
Blow Off	12.34	LC10 Minimum Time	1.23
Seal Temp	12.34	Bag Length	12.34
Index Speed	123	LS10 Down Time	12.34
Reverse	12.34	LS10 Vibrate Rate	1
Spare	12.34	Compart Seal	12.34
Spare	12.34	Twin Seal	12.34
Temp Range	123		
Cool Time	12.34		
Heater Off	12		
Feed Distance	12.34		
Seal Delay	12.34		

Next
Return

Figure 3 - 45

B. External Memory (USB)

To save a job to the External Memory: Select <USB> in the Perf Registration screen (as described in 3.40) and exit to **Main Menu**. Go to **Settings** and set the specifications for your job. Once the job is set, touch <Job Save> which will take you to the Job Save screen, see Figure 3 - 46. Press the box that reads “**Part**” which will access a keypad. In the USB Mode, Jobs can be saved by either numbers or letters. Enter the name or number you wish to save the job as and press enter. To enter a note, press the box that says **Note**, and enter the information using the keypad that is displayed. Touch

Part: ABCDEFGHIJKLMNOPQRSTUVWXYZ
Note: ABCDEFGHIJKLMNOPQRSTUVWXYZ
Qty: 12345

SAVE STOP

Fill Time	12.34	Feed Dist	12.34
Seal Point	12.34	Seal Delay	12.34
Seal Time	12.34	Cool Time	12.34
Seal Temp	123	Reverse Del	12.34
Reverse	12.34	Index Delay	12.34
Index Speed	12.34	Feed Error	12.34
Air Pulse	1.23	Temp Range	123
Blow Off	1.23	Reverse Spd	12.34
Bag Length	12.34	Twin Seal	1.23
Auxiliary Out	12.34	AutoZ TimeOut	12
		AutoZ Range	f1.234

Recipe List
Options Settings
Return

Figure 3 - 46

<Enter> to continue or <Exit> to cancel. Touching the **QTY** box will access a green numeric keypad where the operator can enter the number of products that will go into each bag. For instance, if three items go into the bag before it is sealed, the number 3 can be entered into that field. When all the information is setup touch <Save> to save to the External memory stick.

Note: In the Job Save screen there is a Recipe List button and an Options Settings button. When the <Recipe List> button is pressed, the recipe list screen will be accessed. A record “REC0000” will be displayed. This is the file created by the program which records all the activity on the bagger and where the recipe information is stored. This information can only be viewed when the USB is plugged into a PC. To recall a job, you must type in the name of the job and touch <Enter> in the Job Load screen. When the <Options Settings> button is pressed all the information for that recipe is displayed. The Part, Note, and QTY information can all be changed in this screen. If you do choose to change the information on this screen, go back to the Job Save screen and press <Save> to ensure your changes are saved.

To recall a job from External Memory: Press **Job Search** from the **Main Menu** to access the Job Search screen. From there either scan (if you have a bar code reader option) or enter the job name using the keypad, (accessed by pressing the area under the heading “Current Scan”) and press <Search>, see Figure 3 - 47. This will access a screen listing all the Bag and Factory Settings for this job. Press <Load>, see Figure 3 - 48. This will take you to the Printer Operation Screen with all the settings loaded and ready to start the job.

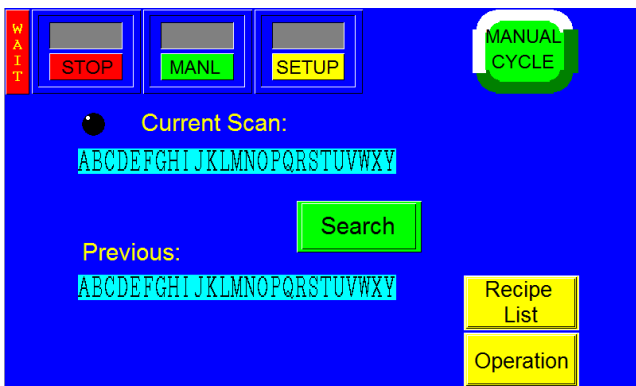

Figure 3 - 47

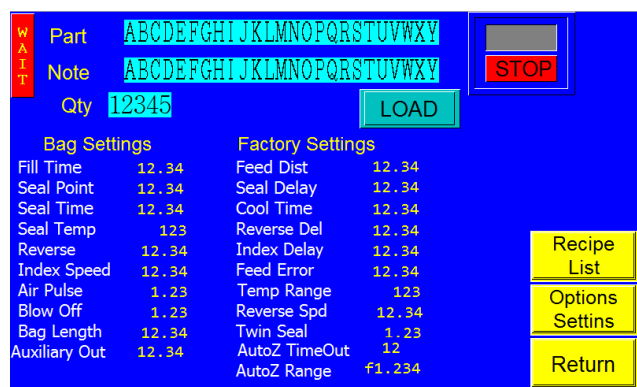

Figure 3 - 48

3.42 Memory Files and Data Structures

While the information related to Bagger settings may be stored internally on the PLC or externally on a USB Memory Stick (Flash Drive) is similar in content, the data structures and methodology are different.

PLC Storage

Information regarding the settings for a particular job, such as Fill Time, Seal Temperature, and Bag Length, are stored in the PLC as data files of various types. These data types include:

- Integers – data type used to store whole numbers
- Floating Point – data type used to store decimal numbers
- Strings – an array used to store characters

These data files are stored in PLC memory and are accessible to the Ladder Logic of the PLC Program File.

See Figure 3 - 49

PLC Memory

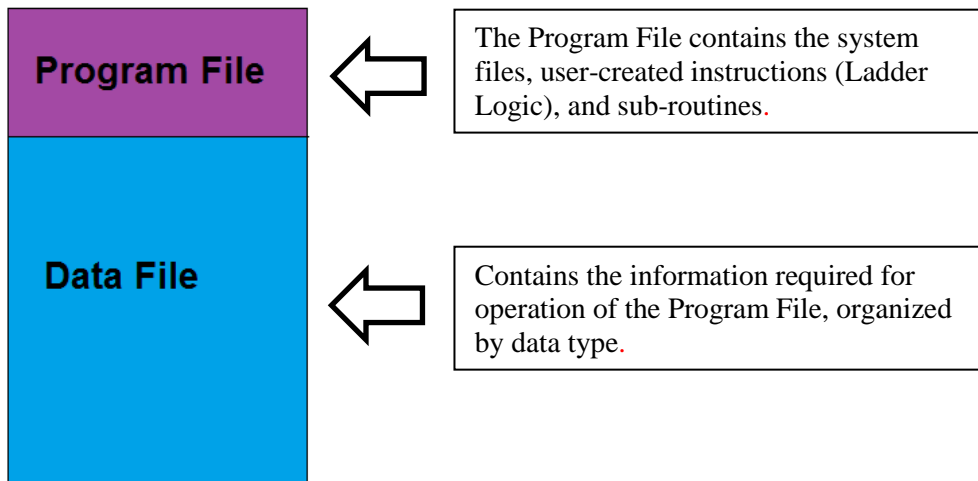

Figure 3 - 49

External Storage

The Memory Stick contains several types of data from the machine. The Bagger Settings are stored, similar to the information in PLC Storage. There are also files for the additional functionality of Recipe Management, and information on Alarm and Production Data. To access this information, plug in the memory stick from the bagger to your PC and open the DAT0000 folder. There will be a list of folders that have been set up by the touch screen program, (see Figure 3 - 50). The two folders that contain the Recipe Data and Production Data are called Recipe and Sample.

Inside DAT000 Folder:



















Name	Folder Name	Contents
 BITMAP	BITMAP	Pattern (bitmap) data
 CARD	CARD	Recipe data using the V6-compatible memory manager function
 DISP	DISP	Screen data
 FONT	FONT	Gothic fonts or language data
 HDCOPY	HDCOPY	Hard copy image (JPEG/BIN format selectable for 128-color display)
 JPEG	JPEG	JPEG file (except for some models)
 LADDER	LADDER	Ladder data associated with the ladder monitor function
 MEMO	MEMO	Memo pad data
 MSG	MSG	Message file
 OPELOG	OPELOG	Operation log file
 RECIPE	RECIPE	Recipe data
 SAMPLE	SAMPLE	Data of data logging and alarm history Title file
 RECIPE	SCRN	Header file
 SAMPLE		Screen file
 SCRN		Component parts (macro blocks, sampling messages) 3D parts file
 SRAM		Windows font file (graphics, messages)
 SRAM	SRAM	Backup copy of SRAM
 WEBSERV	WEBSERV	Files to be accessed from the Web browser

Figure 3 - 50

BITMAP, CARD, DISP, FONT, HDCOPY, JPEG, LADDER, MEMO, MSG, OPELOG, SCRN, SNAP, SRAM, WAV, and WEBSERV are folders used by the touch screen software and will appear empty on the PC. This is because the files are hidden to prevent damage, and therefore do not show up in Windows Explorer. Do not store any information in these files as it will alter the program and will not function when the memory stick is re-inserted in the touch screen.

Note: These hidden files include types used to store images, fonts, functions, database information, and macros that are used to control the Touch Screen, so it is important to not accidentally over-write these files.

RECIPE—contains REC0000.CSV which is a list of all the jobs / recipes saved to the USB memory stick as a .CSV (Comma-Separated-Values) file. This file type is essentially just a table of data in plain text where the values are separated by commas, as in the following example:

Item 1, Item 2, Item 3

This type of file (CSV) can be opened as an Excel spreadsheet.

To access this information, open the <**Recipe**> directory, and then on <**REC0000**>, this will open an Excel file containing all the information pertaining to each job as it was saved on the bagger. This file must be saved (copied) to the PC without the original file changed. Once the file has been saved as a different name than the original, then the operator can use the file and save it as a MS Excel file for full use of the MS Excel formulas.

On the spreadsheet, each row is a separate job / recipe that has been saved in the USB mode on the Bagger, and the columns list all the specifications as it was set on the bagger. Information for each of the jobs starts at column “C” and goes all the way through column “DU”. Some of the common settings are in column C-QTY, AF-Blow-off, AG-Seal Point, AH-Reverse, AI-Seal Temp, AJ-Index Speed, AK-Fill Time, AL-Seal Time, AM-Air Pulse, AN Bag Length, AS-Feed Distance, AT-Seal Delay, AU-Cool Time, AV Reverse Delay, AW-Temp Range, AY-Aux Out.

Note: The program does not save headings for the information being recorded. Also, the data logged is specific to each job; more data is acquired the longer the machine is run. It is recommended that you record each setting for your initial job. This information will be used the first time the spreadsheet is viewed by matching / updating the data to improve your records.

Note: DO NOT change the data in the memory stick. However, you can copy the files and past them into a folder on your PC and then use MS Excel to manipulate the data.

Note: If you are going to change anything on this file, remember to “Save As” a different name to keep the original intact.

SAMPLE—contains .BIN files and .CSV files. The .BIN files are data files stored in a binary format and should not be accessed. Use the .CSV files to view the spreadsheet for each file that contains a different kind of data. The files are:

- **Cycle Log – SMP0003.CSV**
- **Production Time Log – SMP0004.CSV**
- **Event Logs – SMP0005.CSV, SMP0006.CSV and SMP0007.CSV**
(see below for full description of these .CSV files).

This data can be used to provide information about the machine, including number of parts per month. However, these files must be saved (copied) to a PC without the original file changed. Then, the files can be used and saved as MS Excel files for full use of the MS Excel formulas.

Note: There are .BIN files and .CSV files in the Sample folder. DO NOT try to open or change the program used to run the .BIN files. This is the file the touch screen uses to read the information and if it is changed the program will no longer recognize the file. Use the files that have been saved as .CSV.

Note: If you wish to change the data listed in the spreadsheet, “Save As” a different name, then make your changes, keeping the original intact.

Note: Some files may not be used depending on the options of the machine. For instance, if your machine does not have a scale, you will not have any information recorded in the SMP0003.CSV file.

SMP0003.CSV Cycle Log – records every Scale production cycle. (See Figure 3 - 51). The data recorded in each column is as follows:

- A. Date & Time—Records when the occurrence happened
- B. Production#--the number assigned to the production run.
- C. Part#--the number to identify each part.
- D. Part weight—the weight of the part
- E. Target quantity—records the quantity that is to go in the bag.
- F. Actual quantity—records the actual quantity that is in the bag.
- G. FULL/PARTIAL mode—records if the kit is in Full or Partial mode.

Note: There is a Backup Period every day at midnight. A new backup file with full day data is created; old data is then cleared from the buffer to start the new day. Previous records are not erased. Cycle count and timing start over from Zero every day.

	A	B	C	D	E	F	G
1	No.003						
2	14/ 7/25 10:19:14		44	0	22	6	FULL
3	14/ 7/25 10:21:16		55	0	22	6	FULL
4	14/ 7/25 10:21:28		55	0	22	6	FULL
5	14/ 7/25 11:13:58		55	0	22	6	FULL
6	14/ 7/25 11:14:17		55	0	22	6	FULL
7	14/ 7/25 11:29:06		55	0	22	6	PARTIAL
8	14/ 7/25 11:36:22		55	0	22	6	PARTIAL
9	14/ 7/25 11:41:22	PROD NO	55	0	22	6	PARTIAL
10	14/ 7/25 11:46:30	PROD NO	55	0	22	6	PARTIAL
11	14/ 7/25 11:51:49	PROD NO	55	108475.2	22	6	PARTIAL
12	14/ 7/25 11:52:39	PROD NO	55	108475.2	22	6	PARTIAL
13	14/ 7/25 11:55:11	PROD NO	55	108475.2	22	6	PARTIAL
14	14/ 7/25 12:04:45	PROD NO	12345	108475.2	22	6	PARTIAL
15	14/ 7/25 12:06:17	PROD NO	55	108475.2	22	6	PARTIAL
16	14/ 7/25 12:06:39	PROD NO	55	108012.1	22	6	PARTIAL

Figure 3 - 51

SMP0004.CSV Production Time Log – records the length of time the machine has been in production and gives details on the length of time the machine has been in the modes listed below. (See Figure 3 - 52) The data recorded in each column is as follows:

- A. Date & Time—records the date and time the mode was switched.
- B. Power On time—the length of time the power has been turned on.
- C. Auxiliary mode time—the length of time the machine has been in Aux Mode.
- D. Auto mode time—the length of time the machine has been in Auto Mode.
- E. Manual mode time—the length of time the machine has been in Manual Mode.
- F. Stop time—the length of time the machine has been in Stop Mode.
- G. Setup time—the length of time the machine has been in Setup Mode.
- H. Power On total cycles—the number of cycles made since the machine has been powered on.
- I. Auxiliary mode cycles—the number of cycles made since the machine has been in Auxiliary Mode.
- J. Auto cycles—the number of cycles made since the machine has been in Auto Mode.
- K. Manual cycles—the number of cycles made since the machine has been in Manual Mode.
- L. Setup cycles—the number of cycles made since the machine has been in Setup Mode.

	A	B	C	D	E	F	G	H	I	J	K	L
1	No.004											
2	13/ 9/ 6 14:20:30	14645	0	0	1252	12049	1344	0	0	0	0	0
3	13/ 9/ 6 14:20:35	14650	0	0	1252	12049	1349	0	0	0	0	0
4	13/ 9/ 6 14:20:46	14661	0	0	1258	12049	1354	0	0	0	0	0
5	13/ 9/ 6 14:20:49	14664	0	0	1261	12049	1354	0	0	0	0	0
6	13/ 9/ 6 15:01:52	2449	0	0	0	2449	0	0	0	0	0	0
7	13/ 9/ 6 15:01:55	2453	0	0	0	2453	0	0	0	0	0	0
8	13/ 9/ 6 15:08:04	2822	0	0	0	2822	0	0	0	0	0	0
9	13/ 9/ 6 15:08:07	2825	0	0	0	2825	0	0	0	0	0	0
10	13/ 9/ 6 15:08:10	2828	0	0	0	2828	0	0	0	0	0	0

Figure 3 - 52

SMP0005.CSV, SMP0006.CSV and SPM0007.CSV Event Logs – records every Bagger fault event during operation, (See Figure 3 - 53). The data recorded in each column is as follows:

- A. Fault description—the name of the error that has occurred.
- B. Occurrence time—the initial time the occurrence happened.
- C. Clear time—the time the error was acknowledged / reset. **Note: Dashes (---) or asterisks (***) in a field on the spreadsheet indicate no data was recorded for that error.**

Note: There is a Backup Period on 1st of the month at midnight a new backup file with the event list is created. Then old data is cleared from the buffer to start new month.

	A	B	C
1	No.005		
2	Frame open	14/ 7/29 13:55:16	-----
3	Waiting for label	14/ 7/29 13:56:47	14/ 7/29 13:57:01
4	Frame open	14/ 7/29 14:33:38	-----
5	Frame open	14/ 7/29 14:43:38	-----
6	Frame open	14/ 7/29 14:46:27	-----
7	Frame open	14/ 7/29 14:51:00	-----
8	Frame open	14/ 7/29 14:55:01	-----
9	Frame open	14/ 7/29 15:03:28	-----
10	Frame open	14/ 7/29 15:17:12	-----

Figure 3 - 53

Manual Backup: Data is recorded and saved automatically as described above. It can also be done manually using buttons on Log screens:

- 'Write' - overwrite (save) the same file
- 'Backup' - create new file (save as)
- 'Record' - add a new record
- 'Reset' - clear buffer.

3.43 PLC Info

The PLC I/O screens are provided for maintenance personnel to determine the status of the PLC and to review the mode of outputs and inputs. PLC I/O screens are also used to assist APPI service technicians as they work with maintenance personnel to troubleshoot the T-1000-S14 in the field. See Figure 3 - 54 and Figure 3 - 55.

To determine the function of each input and output, press the LED to display a brief description. The PLC I/O screen also provides the run Hours and Cycles counters.

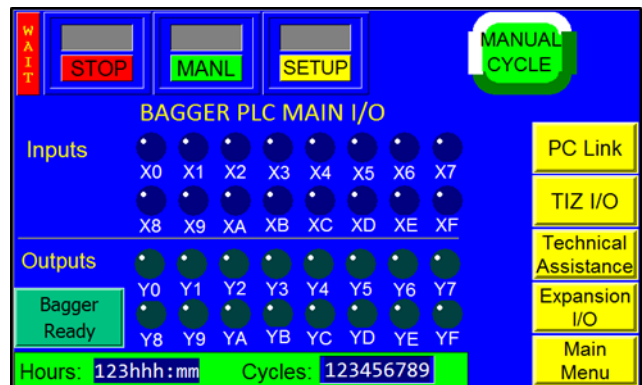

Figure 3 - 54

The Hours counter displays the amount of time the machine has been on. The Cycles counter displays the current number of complete cycles. The operator cannot reset these counters.

3.44 Options Enable Screen

The Options Enable Screen is used at the factory to “enable” options for use by the operator. It is accessed by pressing the <Option PassCode> button on the Technical Assistance screen. (See Figure 3 - 35). This screen should only be accessed by qualified technicians or by the factory.



Figure 3 - 55

A status box is located to the left of each option to indicate if the option is available to the operator, see Figure 3 - 56. If the status box displays ON, the option has been activated. If the status box displays OFF or N/A, the option has not been activated. A password is required to enable inactive options. To obtain the password, the option must first be purchased from Advanced Poly-Packaging, Inc. Contact the APPI Service Department for more information regarding available options for the T-1000 and for instructions on how to activate options.

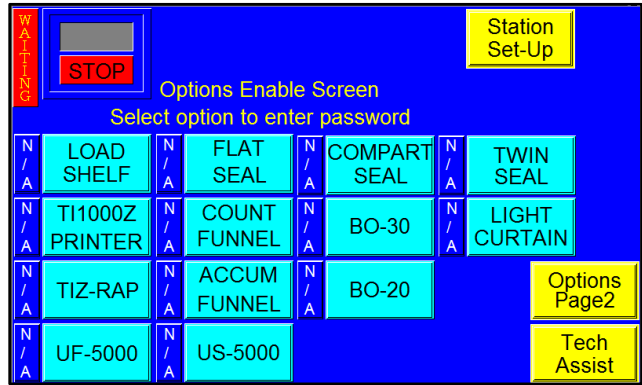

Figure 3 - 56

3.45 License Activation

The License Activation Screen controls access to Advanced Poly-Packaging’s proprietary software for controlling the T-1000 Bagger, and must be activated in order to operate the machine. When shipped from the factory, a 60-day trial activation is included. After full payment for the software is received, a full software license will be granted.

The License Activation and Bagger License Status Screens feature several LEDs that indicate the status of the license and trial period, and illuminate and change during various stages of operation. These screens should only be accessed by a qualified technician.

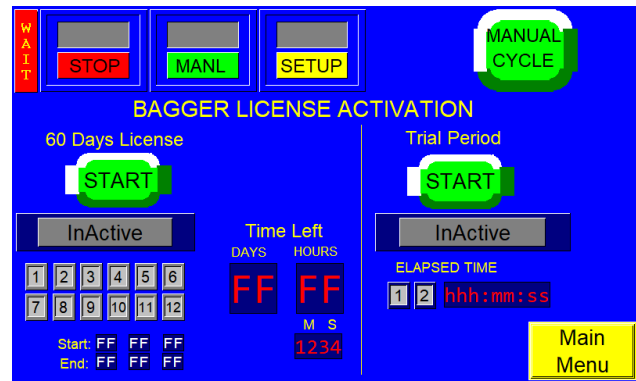

Figure 3 - 57

As shown in Figure 3 - 57, the License portion of the screen will display “Inactive” in grey if the License has not been activated yet, ‘In Progress” in green if the trial is in progress, and “Expired” in red if the License has expired.

Prior to expiration of the trial period, several warning screens may be displayed. These can be seen in Section 3.49, in Figure 3 - 64 and Figure 3 - 65.

When the trial period expiration reminder screen is displayed, the renewal code obtained from APPI can be entered before the current trial period has expired. The new renewal code will be automatically initialized upon expiration of the current trial.

When the license is expired, the bagger will stop and all outputs are disabled and the machine is locked in a safe condition with the temperature shut down until a new activation code is entered.

The **Time Left** will be displayed in days, hours, minutes and seconds.

- Start: Displays when the license period has begun.
- End: Displays when the License period will end.

3.46 Production Graph and Temperature Graphs

Simple production and temperature graphs are provided to chart production and temperature throughout the day. The Detail Temperature Graph allows greater resolution of temperature to one decimal point. See Figure 3 - 58, Figure 3 - 59, and Figure 3 - 60.

Press the <Reset> button once to reset the production time and twice to reset the graph.

Temperature display can be switched between Fahrenheit and Celsius by means of DIP switch #3 on Analog Card. See T1kST-E56_TC4 in Section 4.22.

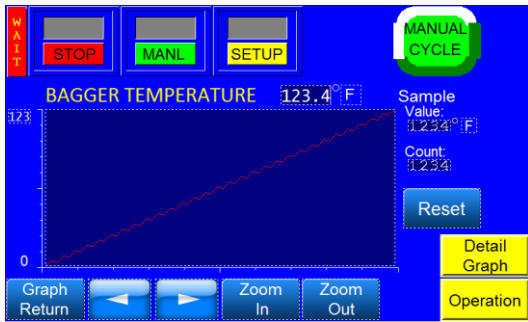

Figure 3 - 58

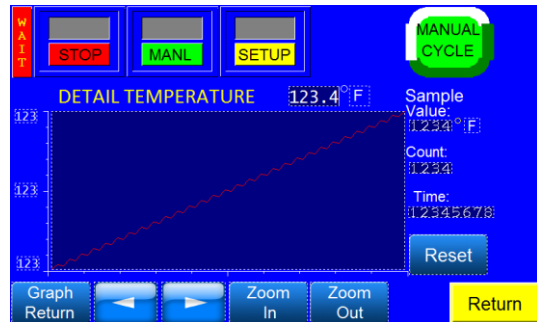

Figure 3 - 59

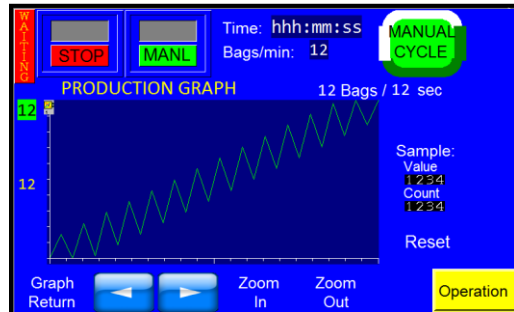

Figure 3 - 60

3.47 Operation Mode Timers, Alarms, & Alarm Data

Several Timers are provided to track Uptime and Downtime. See Figure 3 - 61 and Figure 3 - 62. Alarm logs are also provided. Downtime can be analyzed by view Alarm Data screen which sums all down time associated with each type of fault condition and counts the number of occurrences of each condition.

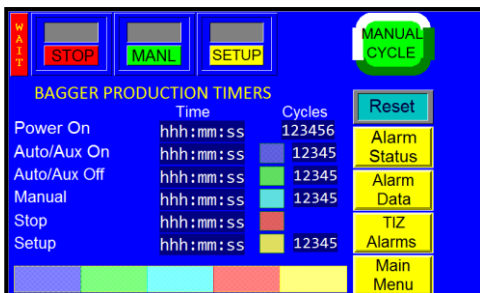

Figure 3 - 61

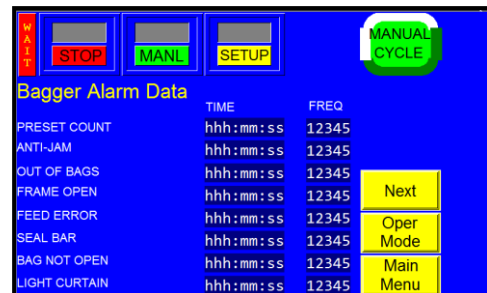

Figure 3 - 62

Note: Timers, Alarms and Data are automatically saved once daily by the machine, either on the internal or external memory, according to the machine setting. Each save creates a new record in the file.

3.48 Bagger Machine Info

Model Number, Serial Number, Part Number and Line Number will be displayed; set at the factory. See Figure 3 - 63.

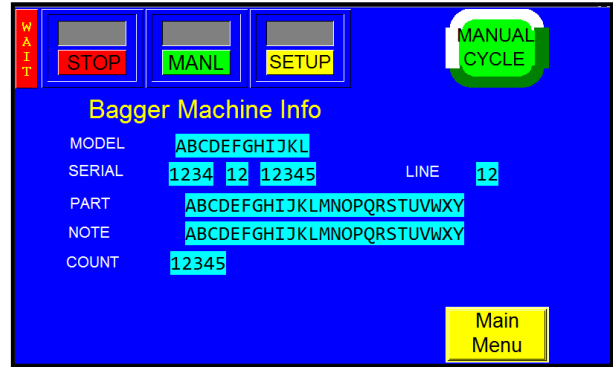

Figure 3 - 63

3.49 Warning and Message Screens

Normal operating message and fault messages will be displayed automatically to alert the operator of situations on the machine. See Figure 3 - 64 through Figure 3 - 72 for examples of messages that indicate the status of the machine, including software license reminders.

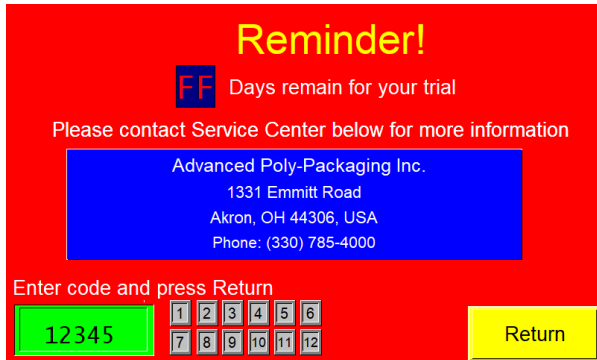

Figure 3 - 64

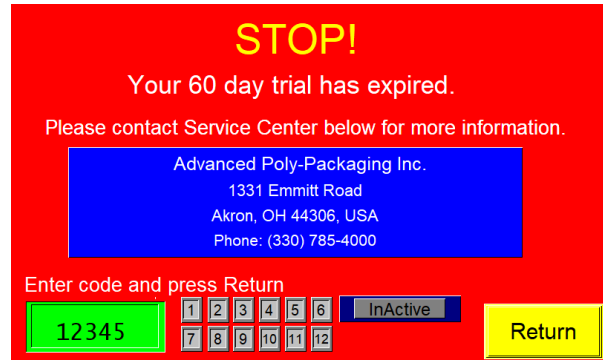

Figure 3 - 65

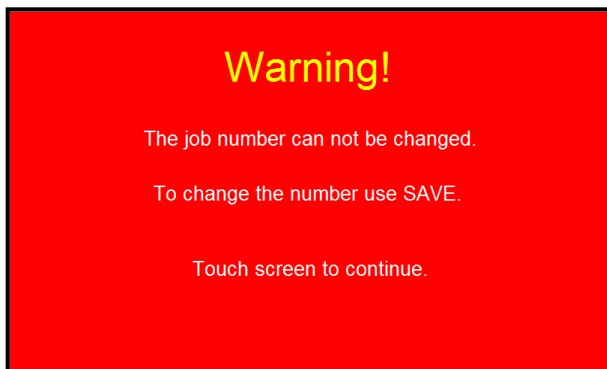

Figure 3 - 66

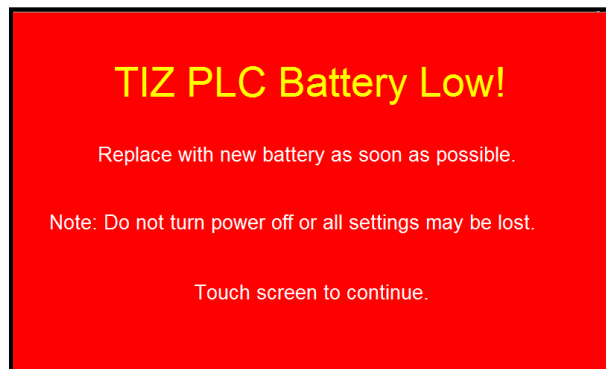

Figure 3 - 67

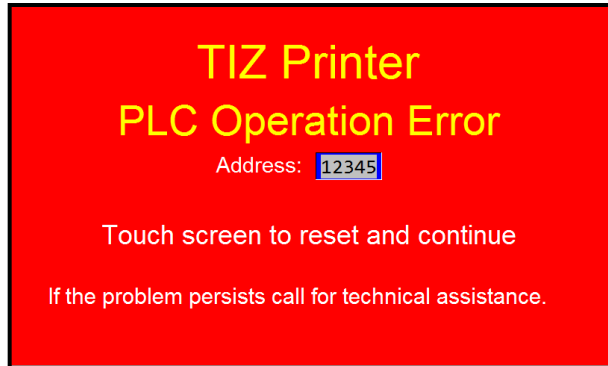

Figure 3 - 68

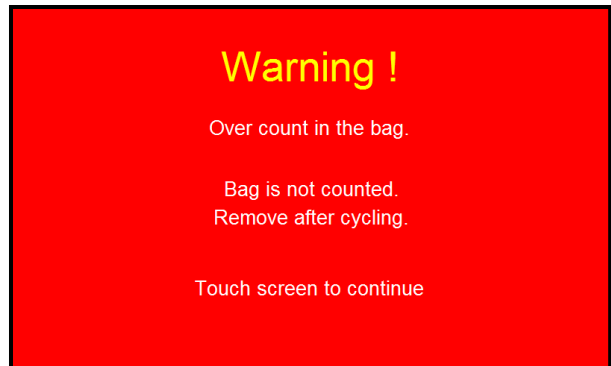

Figure 3 - 69

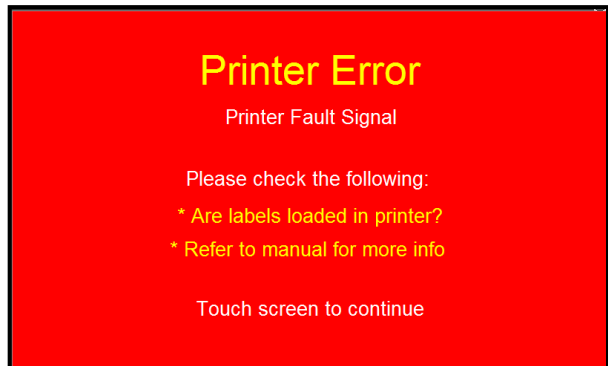

Figure 3 - 70

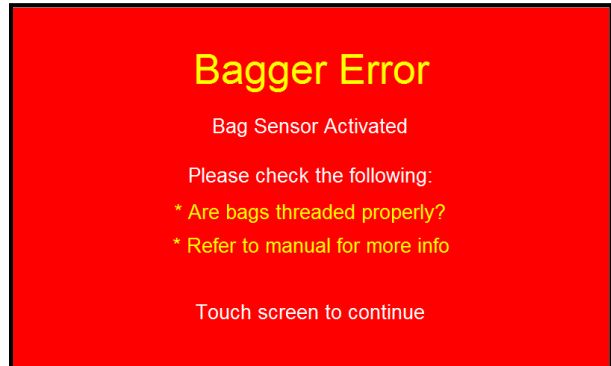

Figure 3 - 71

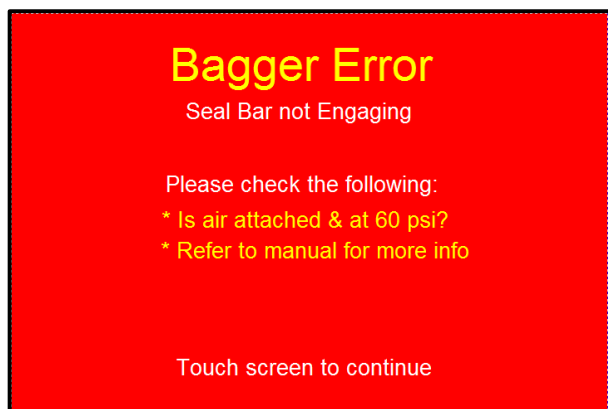

Figure 3 - 72

Chapter 4: Adjustments Maintenance, Troubleshooting

Machine Adjustments

Compression (Nip) Roller Adjustment

Dancer Assembly Adjustments (Roller Shaft)

Dancer Bar and Brake Strap Adjustment

Upper Roller Guides

PTFE Adjustment

PTFE Replacement

Pressure Bar Adjustment

Sealer Cylinders Adjustment

Pressure Bar (Rubber) Replacement

Anti-Jam Adjustment

Heater Cartridge Replacement

Replace Thermocouple Wire

Preventative Maintenance and Scheduled Maintenance

Preventative Maintenance Checklist

Scheduled Maintenance Chart

Preventative Maintenance Chart

Spare Parts Kits

Troubleshooting Guide

Troubleshooting Checklist

PLC IO Listing

Schematics

4.1 Machine Adjustments

Periodically, the T-1000-S14 will require readjustments or realignments of components to ensure proper operation. Adjustments may be required after transportation, excessive handling or due to normal wear and tear. The following chapter includes extensive information on how to make these adjustments. "How To" documents for many machine adjustments, replacements or troubleshooting techniques are in the Help Function of our website: www.advancedpoly.com.

CAUTION: Machine adjustments, electrical troubleshooting and component replacement should be performed by qualified maintenance technicians familiar with safety practices including, but not limited to, equipment lock-out / tag-out, voltages and pneumatics. If you are not familiar with the equipment or have not received training on the T-1000-S14, consult with APPI Technical Support before attempting adjustments or repairs.

4.2 Compression (Nip) Roller Adjustment

The drive roll compression is the force that exists between the two feed rolls (rubber-covered grooved roll and grooved steel roll). Too little drive roll compression will prevent the bags from tearing off after each sealing operation. Too much drive roll compression will cause extra wear on the drive roll and the motor.

Note: Always clean rollers before adjusting.

Turn the power switch to the OFF position and unplug the power cord. Remove the left and right-side covers. The compression adjustment is located on the lower outside right and left side plates. See Figure 4-1 and Figure 4-2.

Compression adjustment is a two-step process. First, the lower roller is adjusted so that it is parallel to the upper roller. Then, the lower roller is adjusted (raised) for proper compression.

On both the left panel and right panel, loosen the two locking bolts on the upper block of the compression tension assembly. Loosen the nut on the adjustment screw. With the Seal Frame locked in the UP position, lower the lower (steel) roller by turning the adjustment screws clockwise until the lower (steel) roller is parallel to the upper (blue) roller, leaving a 1/16" gap between the rollers. Turn the adjustment screw counter-clockwise alternatively, keeping the lower roller parallel with the upper roller until the rollers come in contact across the width of the rollers. Slightly lower the inner frame and raise again to ensure that when raised again, the rollers touch simultaneously. Then "snug" the upper block bolts and recheck the alignment.

Note: A light source (lamp) positioned to the rear of the T-1000-S14 showing light in the gap of the rollers will assist in judging whether the upper and lower roller are parallel.

With the rollers parallel and slightly touching, turn each adjustment screw approximately 1/8 turn counter-clockwise. Then test the compression by putting a bag between the rollers and attempting to pull the bag between the rollers. If the bag pulls out easily, turn the compression adjustment screws 1/8 turn counter-clockwise. Continue this adjustment until the bag is slightly difficult to pull out of the rollers.

CAUTION: Over-tightening of the compression adjustment screws may cause damage to the upper (rubber) roller or the motor.

When you are satisfied with the compression, slightly lower the Seal Frame, and then slowly raise it until it almost touches the upper roller. If the gap is consistent across the width of the rollers and it appears parallel, lock the Seal Frame upward and retighten the two locking bolts on the upper block of the compression tension assembly. Then retighten the nut on the adjustment screws. Replace the covers, plug the cord into the power outlet, and turn the main power on.

LEFT SIDE PANEL COMPRESSION NIP ROLLER ADJUSTMENT

Figure 4-1

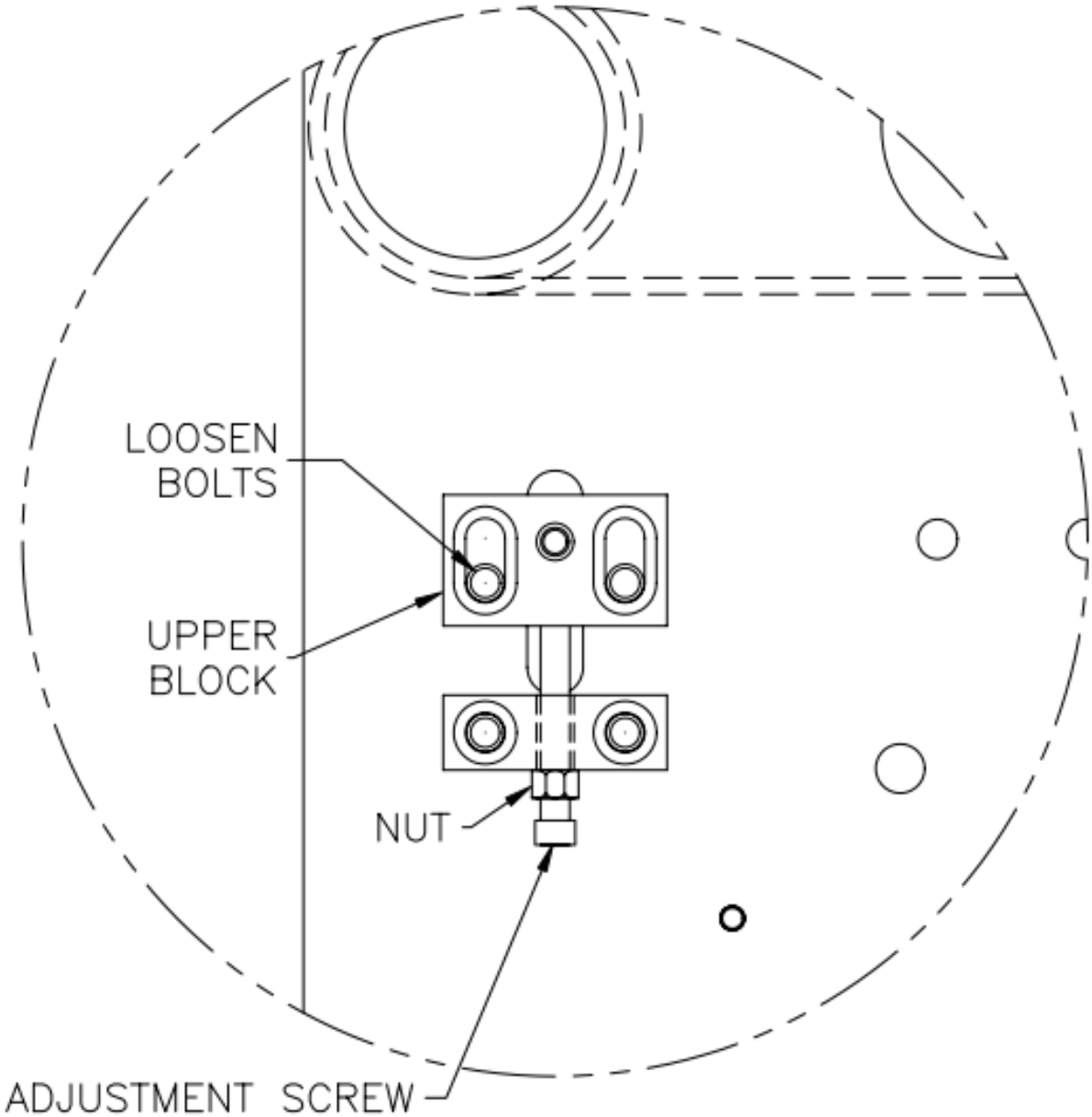

RIGHT SIDE PANEL COMPRESSION NIP ROLLER ADJUSTMENT

Figure 4-2

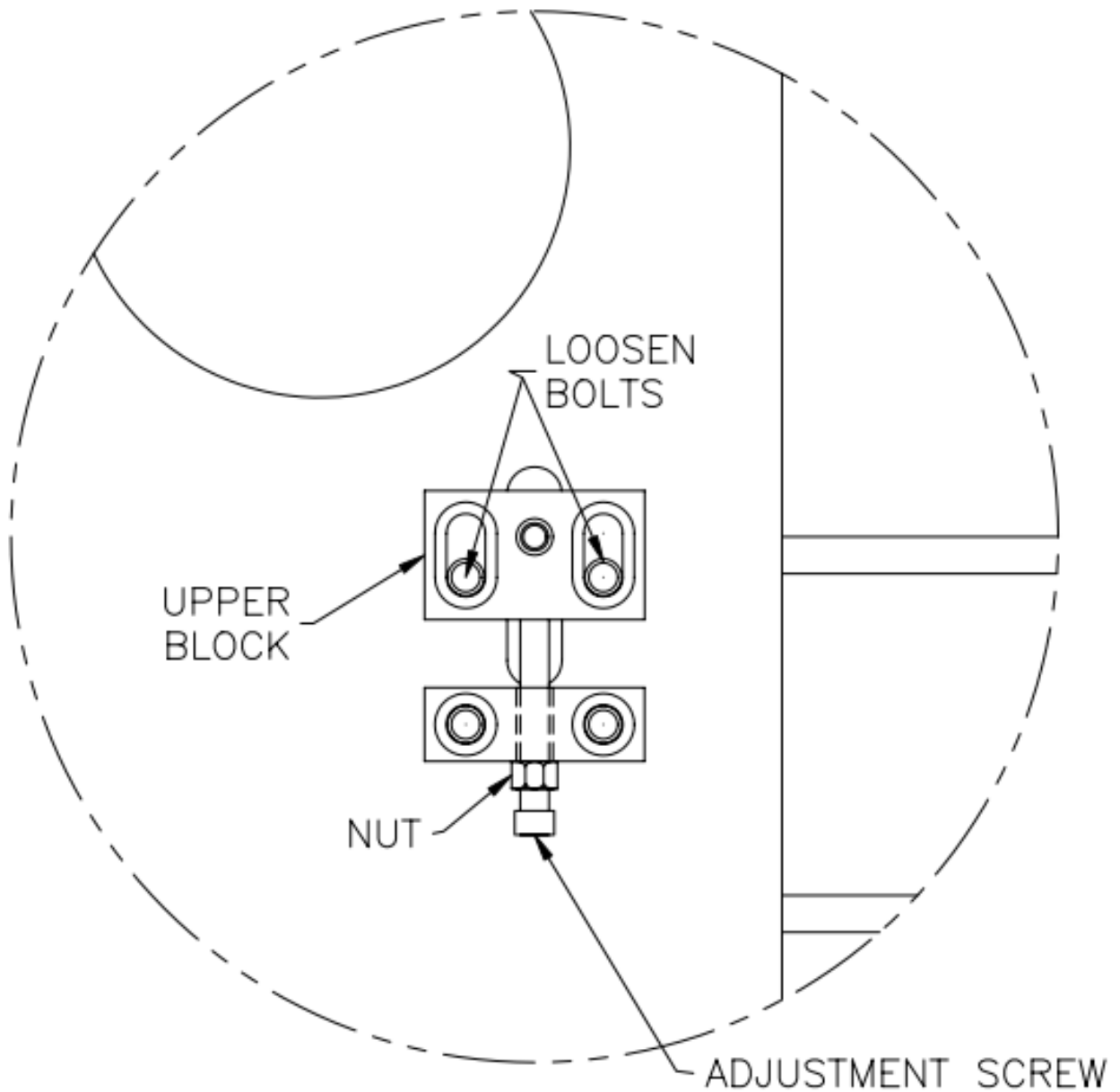

4.3 Dancer Assembly Adjustments (Roller Shaft)

Please refer to 5.6 Dancer Assembly when using these instructions. A roller shaft, holding in position a roll of bags, will rest on the side plates of the dancer assembly. The roller shaft must be parallel to the upper and lower guide rollers to allow proper tracking through the center of the T-1000-S14. If the roller shaft is not parallel, the web of bags may track to the left or right.

Note: *The roller shaft should not be out of alignment unless damaged or jolted in shipment.*

If the rollers are not parallel, loosen two Socket Head Bolts on Dancer Frame and move Dancer Frame backward or forward until the Dancer Roller is parallel with Guide Rollers on the T-1000. When Guide rollers are parallel with Dancer Rollers, tighten the bolts on the Dancer Frame.

4.4 Dancer Bar and Brake Strap Adjustment

The dancer assembly maintains proper bag web tension throughout the stop/start feed motion. Web tension is required for proper tracking. If the tension is insufficient, the web may track left or right. Thinner bags require less tension than thick bags. Web tension is created by the friction of the brake strap along with the weight of the dancer bar pulling downward on the web of bags. Friction of the brake is created by the weight of the bag roll and the spring tension on the brake strap. As the dancer bar rises, spring tension is decreased and friction is decreased. If the web of bags is slack between the dancer roller and nip rollers, there is not enough tension on the bags. If the web of bags breaks prematurely, the tension is too high.

To correct the web tension, the dancer bar or brake strap spring must be adjusted. To increase brake strap tension, relocate the spring on the dancer rail by sliding the block closer to the dancer roller. To decrease tension with the brake strap, move the spring on the dancer bar and slide the block back away from the dancer roller.

The dancer bar pivots on two shoulder bolts that extend from the side plates. The downward force can be adjusted by repositioning the pivot point. To increase tension with the pivot position, move the pivot position away from the dancer roller. To decrease tension, move the pivot position closer to the dancer roller.

Note: *For the brake strap to function correctly, the roll shaft must be installed so the strap wraps around the roll shaft. Inspect the dancer bar to ensure that it is parallel to the roller shaft.*

4.5 Upper Roller Guides

Two plastic web guides are located on the upper rear roll of the T-1000-S14 and are used for *fine* adjustment of tracking. Once the web is tracking within +/- 1/8" (0.31 cm) left to right, the plastic web guides can be used to further assist with tracking. Hold the upper roller in place while turning and sliding the plastic guides close to the bags without touching the bags.

Note: *If the bags are not tracking properly, the plastic guides could cause the bag web to turn or fold over. If this occurs, slide the guides further away from the web and make adjustments to correct tracking issues.*

Note: *If bags have an air relief hole or hanger hole, shift the bag to the right or left of center to avoid having the hole pass directly under the perforation sensor.*

Note: *Use the web guides for minor adjustments only. Major adjustment of the guides requires relocation of the bag roll on the bag roll shaft.*

LEFT SIDE PLATE PTFE ADJUSTMENT

Figure 4-3

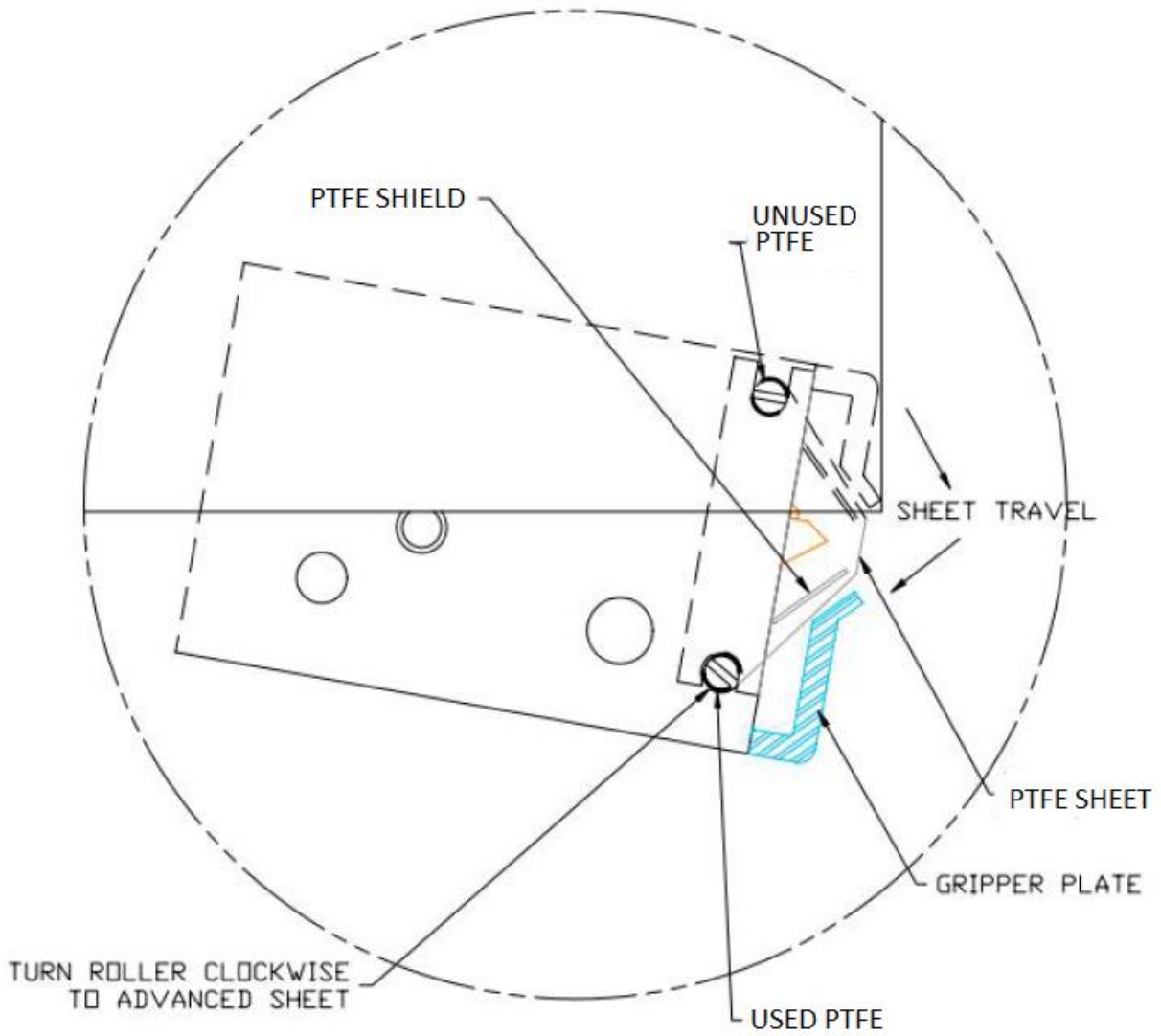

4.6 PTFE Adjustment

A non-stick PTFE sheet that prevents the bag from sticking to heater bar surfaces is located immediately behind the front plate. The PTFE should periodically be inspected for wear or damage. If holes or tears exist, the rolls can be turned (rotated) to cover the contact surfaces with fresh material.

If an adjustment of PTFE is required, turn the main power OFF and unplug the power cord. Lower the inner frame by pulling the handle downward. The rollers are located on the outside lower frame, on the left and right side of the inner frame that extends beneath the side plates. See Figure 4-3.

To adjust the material, turn the lower roller counter-clockwise approximately $\frac{1}{4}$ of a turn using a flathead screwdriver. If there is too much tension on the sheet, turn the roller counter-clockwise, releasing all of the tension on the sheet. If there is too much slack in the sheet, turn the top clockwise.

CAUTION: *If sheet tension is not released, the material will tear when the seal bar engages.*

4.7 PTFE Replacement

Once the PTFE Sheet has reached the end of the roll, it is time for it to be replaced. To order a replacement sheet, call APPI Service and refer to part number TP-300500.

1. Turn the power to the OFF position and unplug the power cord. Let machine cool for at least an hour.
2. Remove the Lexan guard by unscrewing the two acorn nuts connected to the shafts. Remove the four Button head screws that hold the Front Plate to the inner frame. Set these aside in a safe place.

Note: *Fiber spacers located behind the front plate may fall when removing the Front Plate screws.*

3. Slide the Front Plate back and remove PTFE Guide. Determine if your machine is a Standard Frame or a Drop Frame. Look closely at the PTFE Sheet Bracket. If you have a Standard Frame the LONG side of the PTFE Sheet Bracket goes up. If you have a Drop Frame the SHORT side goes up. This is important for reassembly.
4. Remove the two springs and clean the adhesive from both shafts. See Section 5.10c for Exploded Diagram.
5. Separate the two shafts.
6. Lay one Shaft on the top of the PTFE Sheet and measure from the edge of the sheet to the edge of the Shaft. Ensure the sheet is in the center of the Shaft.
7. Wrap a piece of tape on the Shaft at the edge of the material.
8. Take the second Shaft, lay the first Shaft next to it and wrap tape around the end of the second Shaft in exactly the same place as the first. Keep the taped ends on the same side of the PTFE Sheet.
9. Remove the adhesive backing from one end of the PTFE Sheet.
10. Align one Shaft parallel to the PTFE Sheet with the taped end of the Shaft meeting up with the edge of the PTFE Sheet. Once the shaft is in position, lower onto adhesive side of the PTFE Sheet.
11. Roll the Shaft until you reach the end of the adhesive part.
12. Repeat with the other Shaft, ensuring the taped ends are on the same side. Once the PTFE Sheet has been rolled over the Shafts, the tape may be removed.
13. Determine if your machine is a Standard Frame or a Drop Frame. Look closely at the PTFE Sheet Bracket. If you have a Standard Frame the LONG side of the PTFE Sheet Bracket goes up. If you have a Drop Frame the SHORT side goes up.
14. Lay the PTFE Sheet Bracket in the middle of the PTFE Sheet.
15. Place the Shaft into the cutouts of the Bracket then pull the spring so that you have two wraps between the Bracket and the Shaft. Be sure the Spring is in the groove on the Shaft.
16. Repeat the same procedure on the other Shaft.
17. Wind the PTFE so that the supply is at the TOP of the PTFE Sheet Bracket. Standard Frame, LONG side up; Drop Frame, SHORT side up (refer to step 13)
18. Place PTFE Sheet Bracket Assembly back into the bagger. If your machine is a Standard Frame, ensure the LONG side is up, and for a Drop Frame the SHORT side is up.

19. Slide the Front Gripper Plate back into position.
20. Place Front Plate Spacers behind Front Plate, insert button head screws, then tighten.

4.8 Pressure Bar Adjustment

The pressure bar, when actuated by the seal cylinder, is forced against the front plate. The pressure bar must be parallel to the front plate to avoid excessive wear of components. Please contact Advanced Poly-Packaging Service for Pressure Bar adjustment instructions.

Note: *Pressure bar adjustment should only be necessary after rod or bushing replacement.*

4.9 Sealer Cylinders Adjustment

Flow controls operate the air flow which dictates the speed of the cylinder in an “in-and-out” motion that brings the Pressure Bar against the front plate (Gripper Plate). Increasing the speed of the Pressure Bar will increase production. But if the Pressure Bar moves in or out too fast, the Pressure Bar will “bang” and excessive wear will occur. The inline Flow Control that controls the Pressure Bar Cylinder is located on the tubing to the main center cylinder on the inner frame. See Figure 4-4.

The adjustment knob (B) controls the speed of the Pressure Bar INWARD (towards the front gripper plate). To increase the speed of the Pressure Bar INWARD, turn the knob (B) counterclockwise. To decrease the speed of the Pressure Bar INWARD, turn the knob (B) clockwise.

Note: *There is no OUTWARD adjustment for the Pressure Bar.*

The adjustment knob (A) controls the speed of the Heater Bar OUTWARD (away from the front Gripper Plate). To increase the speed of the Heater Bar OUTWARD, turn the knob (A) counterclockwise. To decrease the speed of the Heater Bar OUTWARD, turn the knob (A) clockwise. Adjust the speed of the Pressure Bar so that it moves in and out rapidly, in a fluid manner, without causing the Pressure Bar to “bang” in or out.

Note: *There is no INWARD adjustment on the Heater Bar.*

4.10 Pressure Bar (Rubber) Replacement

Located along the inside of the pressure bar is a strip of rubber, held on the pressure bar by a channel, pressing on the edges of the rubber. The rubber compresses against the front (gripper) plate holding the bag in place during sealing and bag tear-off. If the rubber becomes brittle, torn, gouged, or otherwise worn, it should be replaced to assure strong seals.

To replace the pressure bar rubber, simply pull one end of the rubber from the channel. The rubber will come out of the channel quickly and easily. To install a fresh piece of rubber, press one edge of the rubber into the channel, then the other edge. Work the rubber into the channel in small increments along the length of the channel. See Figure 4-5 and Figure 4-6. If you used PTFE tape to cover the surface of the rubber, place the PTFE on the rubber along its length. If the PTFE extends beyond the rubber, cut off the excess.

Note: *PTFE may be added to the pressure bar rubber if the bag sticks to the rubber after loading and sealing. The bag may stick to the rubber if the product and bag are lightweight and if the rubber is dirty.*

Note: *Frequently clean the rubber with alcohol to remove buildup of dirt or other contaminants.*

SEAL CYLINDER ADJUSTMENT

Figure 4-4

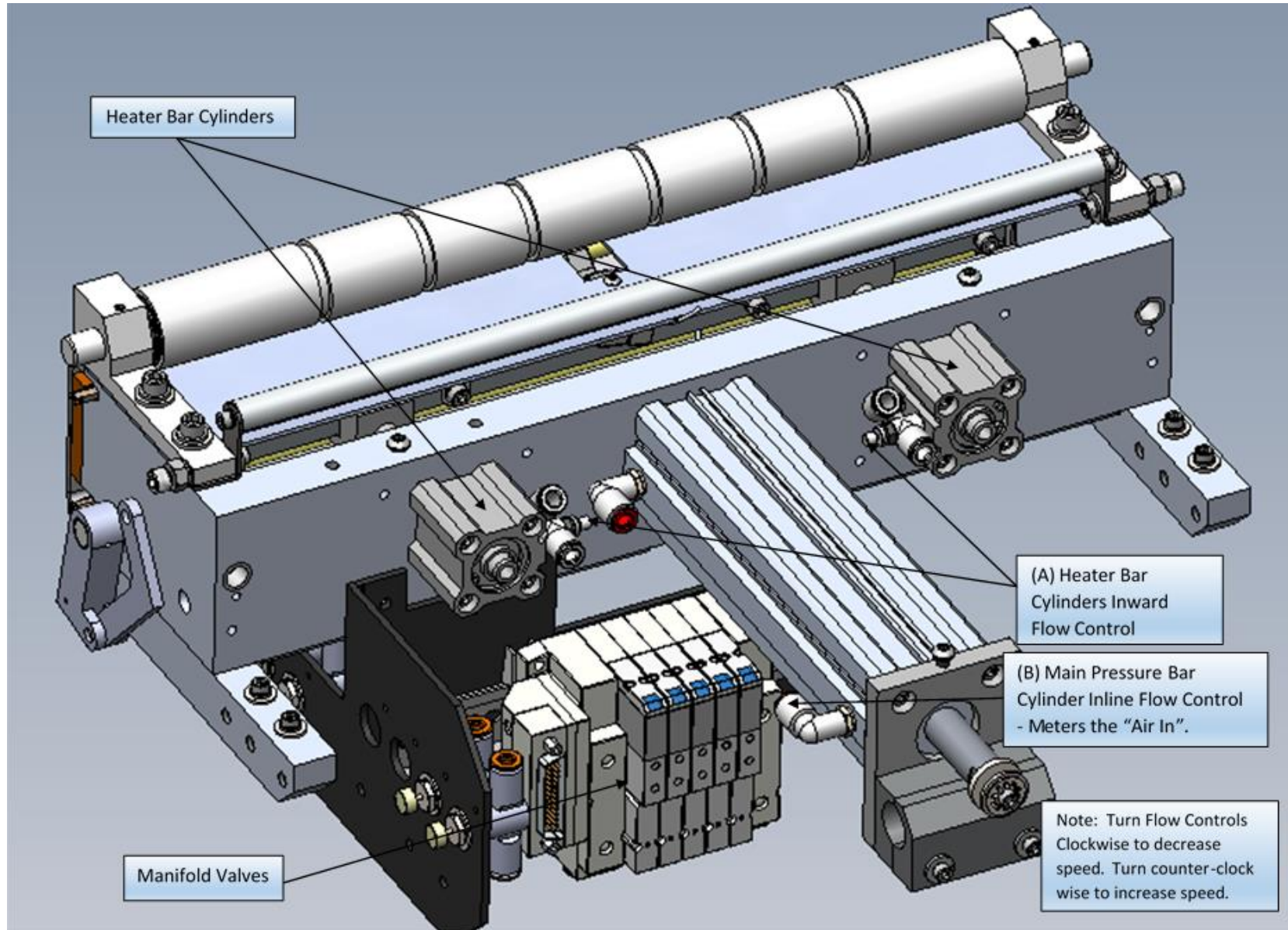

PRESSURE BAR REPLACEMENT

Figure 4-5

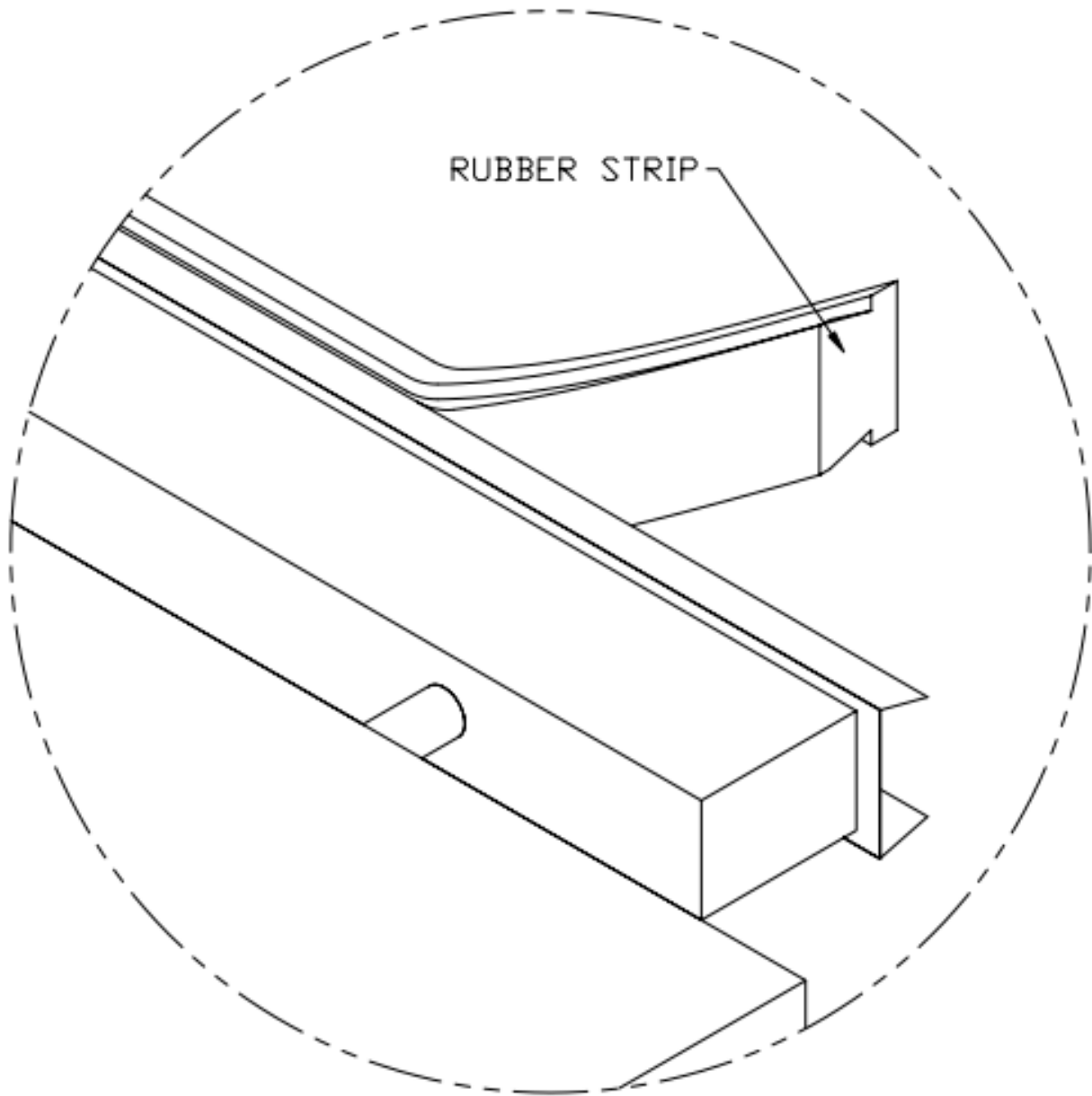

PRESSURE BAR REPLACEMENT

Figure 4-6

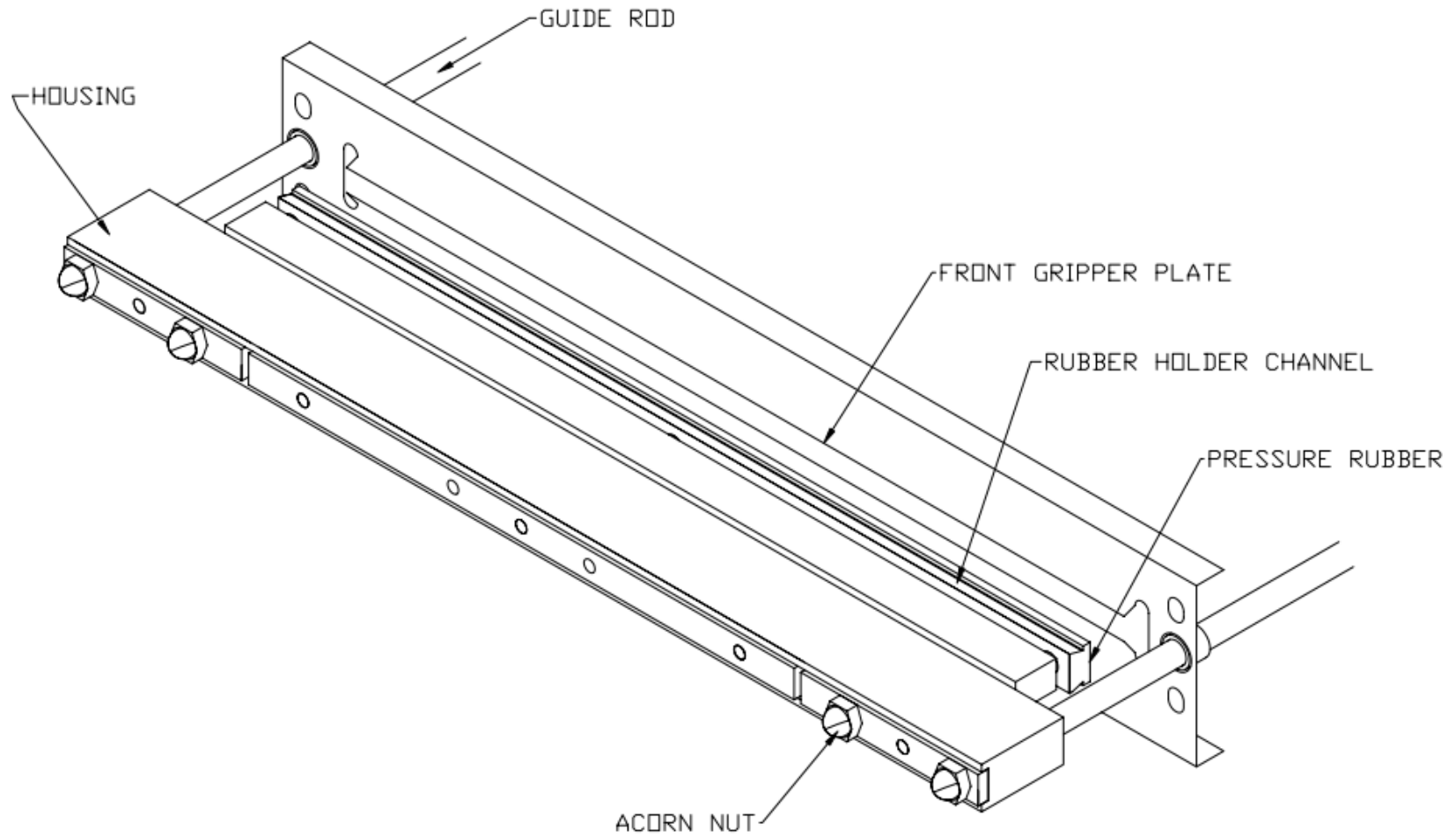

Note: There is a 1/8" gap between the pressure rubber and front gripper plate.

4.11 Anti-Jam Adjustment

The anti-jam device is designed to protect the T-1000-S14 from damage when an obstruction is encountered in the seal area, between the pressure bar and front gripper plate. If properly adjusted, the pressure bar will retract if an obstruction is encountered in the seal area. The pressure bar houses springs that cause the rubber and holder to compress. When the rubber holder compresses, a sensor is activated, causing the pressure bar to retract. The sensor is defeated when the pressure bar is approximately 1/8" from the gripper plate. See Figure 4-7. The anti-jam device can quickly be tested while the T-1000-S14 is operating using care, but it should be thoroughly tested by disconnecting air and power and removing covers.

To quickly test the anti-jam device, place a 3/8" diameter flexible poly tube against the front gripper plate perpendicular to the seal bar opening. Press the foot switch allowing the pressure bar to compress the poly tube against the front plate. If the pressure bar does not immediately retract and place the T-1000-S14 in the STOP mode, the anti-jam device is not properly adjusted. Test the anti-jam device along the entire length of the pressure bar using the 3/8" poly tubing as a test device.

CAUTION: To avoid personal injury, do not place fingers or hands into the seal area of the T-1000-S14 while power is ON or air is attached. Do not test the anti-jam device with hands or fingers. Ensure the poly tube that is used for testing is long enough to keep fingers or hands away from the seal area of the T-1000-S14.

Part 1: Anti-Jam Test

To thoroughly test and adjust the anti-jam device, you must first turn the power to the OFF position and disconnect the air line from the T-1000-S14. Remove Top Cover by unscrewing the two Button Head Screws, one on each side of the top- rear of the machine. Keep these screws in a safe place. Remove the top cover. With the covers removed and air disconnected, turn the power to the ON position.

With Power on, access the Main Menu on the Touch Screen, press Technical Assistance, and enter Level 1 Pass Code (1001). Press ENT.

On the Technical Assistance screen, press PLC Info to access the PLC I/O screen. You will be checking to see if the X7 LED illuminates when the Anti-Jam is tested.

From the front of the machine, move Pressure Bar in until the rubber is approximately 1/8 inch from touching the angle of the Gripper Plate.

Locate the Seal Rod and Magnetic Sensor Block on the left side of the T-1000.

With an Allen Wrench, loosen the Magnetic Sensor Block and slide Magnetic Sensor Block towards Magnetic Switch until X7 just illuminates.

At this point, tighten the Magnetic Sensor Block at the place where X7 illuminated. Be sure it is straight up and down and clears the Magnetic Switch.

CAUTION: To avoid damaging the plastic override sensor, position the sensor so that it does not contact the magnetic block when the pressure bar is moving. To avoid "stripping" the threads of the sensor, do not over tighten the securing nuts.

Re-Attach Air Supply by attaching the female quick-coupler to the male quick-coupler on the filter regulator assembly.

Anti-Jam is working. Put the T-1000 in Auto Run and let it cycle. While it is running perform the Anti-Jam test again by placing a piece of 3/8 tubing doubled over and place in between Pressure Bar and Heat Bar. The Pressure bar should jump back and the Touch Screen should give an Anti-Jam error screen.

ANTI-JAM OVERRIDE ADJUSTMENT

Figure 4-7

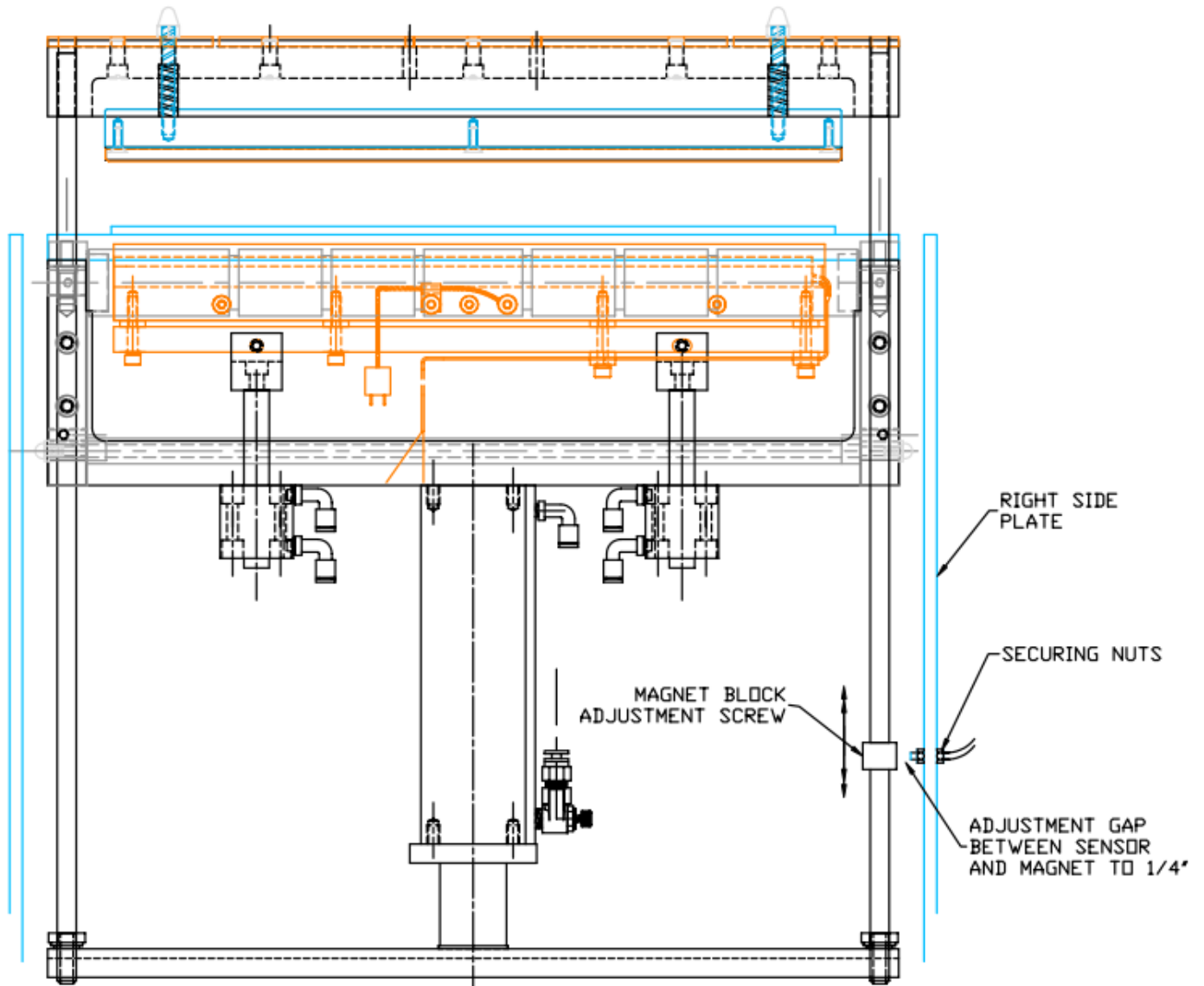

Part 2: Other Anti-Jam Testing

Next, locate the "X4" LED on the PLC Info Screen (under Technical Assist) and ensure the light is illuminated (ON). Then, compress the rubber and holder into the pressure bar (nylon holder). As soon as the rubber is pressed into the nylon holder, the "X4" LED should turn OFF. The LED should remain off while the rubber is held compressed into the nylon holder. If the "X4" LED shuts off while the rubber bar is pressed into the nylon holder, the pressure bar sensor is functioning properly.

Note: Acorn Nut base should be flat making full contact to the surface of the plate. If the Acorn Nut is worn, it will need replaced. Call APPI and refer to Replacement Part # TP-101131 (Nut, Acorn Brass Nickel Plate) when reordering.

Note: X3 is used on the T-1000 Clutch Brake and X4 is used on the T-1000-S14.

If the X4 LED is OFF when the rubber bar is not depressed into the nylon holder, the Coiled Cable, located inside the Main Frame of the T-1000-S14, must be tested and the two Acorn Nuts must be checked for wear. Check the cable for any cuts or worn spots that could be going to ground. If there are signs of wear and tear it must be replaced. Refer to Part # TP - T1ME00209, Seal Bar Coiled Cable Harness when reordering from APPI Service.

If the coil is intact and it is still lighting when the Rubber Bar is depressed, unplug the Coiled Cable Harness located inside the Main Frame of the T-1000-S14. Using an electric meter set on Ohms, put the test leads on the coiled cable side and measure the resistance, it should be 0 or closed.

Squeeze the pressure bar. The meter should now show resistance or open. If it does, reconnect coiled cable, reattach Lexan Cover with Acorn nuts, and continue with production. If it does not, the coiled cable will need replaced. Call APPI Service and refer to P/N: TP-T1ME00209, Seal Bar Coiled Cable Harness when reordering.

4.12 Heater Cartridge Replacement

A cylinder-shaped cartridge (element), located inside the heater bar, heats the bronze bars that contain it. This cartridge is considered a normal wear item and will infrequently fail, requiring replacement. Refer to Figure 4-8 while following these instructions.

To determine if the heater cartridge is bad, use the following troubleshooting steps:

1. Check resistance value of heater cartridge. At room temperature, a 110V machine should read approximately 18 Ohms, and a 220V machine should read approximately 60 Ohms.
2. Locate the "Y3" indicator on the **PLC info** screen.
3. Press the <START> button if the T-1000-S14 is in the Stop mode. If "Y3" illuminates in long pulses without increasing the temperature on the Bagger Settings screen, the Heater Cartridge will need replaced.

Note: If you do not have an Ohms meter, start at step 2.

If the Heater Cartridge needs replaced, please call APPI Service.

HEATER BAR CARTRIDGE REPLACEMENT

Figure 4-8

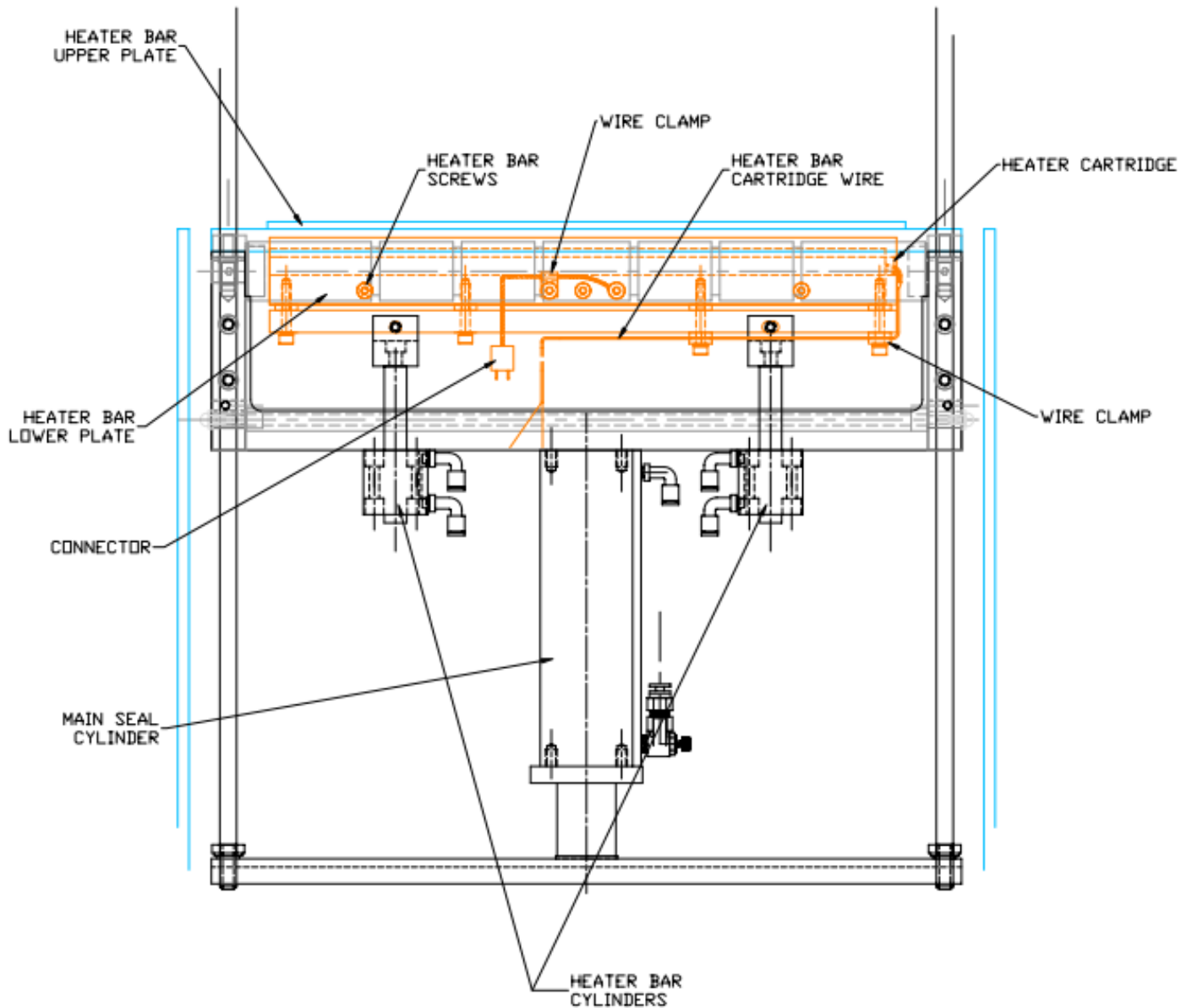

VIEW FROM UNDERNEATH THE INNER FRAME

Note: Heater cartridge wires must make a sharp 90° bend at the end of heater bar. Wires should not extend past the end of the heater bar.

Note: If the wires rub on the bagger when the heater bar is in or out, the heater cartridge will fall prematurely.

4.13 Replace Thermocouple Wire

A thermocouple wire, brazed to a ring terminal and secured to the bottom of the heater bar, detects the amount of heat the heater bar is emitting. The thermocouple wire is considered a normal wear item and will infrequently fail, requiring replacement.

The thermocouple should be replaced when excessive fluctuations occur or incorrect temperature is displayed in the Bagger Settings menu. The thermocouple should also be replaced when a visual inspection reveals frayed insulation or broken wire. If the above conditions are met, the thermocouple is bad and the current to the heater bar has been turned OFF.

To replace the thermocouple wire, turn the main power to the OFF position, unplug the power cord and disconnect the air line. Let machine cool for at least an hour.

Remove the Gripper Plate and PTFE assembly, take note as to which side of the PTFE Sheet Bracket is up (the SHORT side of the groove on the bracket will be up for Drop Frame or the LONG side of the groove will be up for Standard Frame). Unplug the Heater Cartridge and Thermocouple wires, then remove the two shoulder bolts holding the Heater Bar in the yolks. Remove the Heater Bar. Remove the screws that hold the ring terminal and the jacketed wire clamp. Disconnect the connector and remove the wire. Reverse these steps to replace the wire and reattach Heater Bar.

Note: there is a top side and a bottom side to the thermocouple eye, the top side is flat and shiny, the bottom side has a slight groove in it. Attach the thermocouple wire so the top side is facing out.

CAUTION: To avoid stretching or breaking the wire during heater cylinder extension, ensure that the wire is looped and free to bend during heater bar movement.

Replace the PTFE assembly ensuring the correct side is up, then reattach Gripper Plate.

4.14 Preventative Maintenance and Scheduled Maintenance

To extend the life of the T-1000-S14, qualified maintenance personnel must perform all required maintenance tasks. Failure to perform scheduled and preventative maintenance may cause excessive wear to components and will void the warranty. For the purpose of this manual, preventative maintenance (PM) tasks are considered periodic tasks that should be performed on a daily, weekly, or monthly basis.

Scheduled maintenance tasks are performed when the T-1000-S14 Maintenance Chart Number changes to a higher number. Scheduled maintenance tasks (CHART items) are performed depending on the number of machine cycles and therefore are not considered "periodic" tasks.

4.15 Preventative Maintenance Checklist

CHART

ITEM	DESCRIPTION	PERIOD
Filter / Air regulator	Drain water from filter	D
Air regulator	Adjust pressure to 60 PSI	D
Anti-jam device	Check operation, adjust as needed (section 4.11)	D
Pressure bar (rubber)	Clean with alcohol	D
Perforation sensor	Clean sensor assembly with alcohol	W
Upper (rubber) roller	Inspect for nicks or cuts; clean with alcohol	W
Lower (alum.) roller	Clean with alcohol	W
Micron filter / Ventura	Inspect for contamination of filter, replace as needed Inspect for blockage / air restriction	M
Wiring / Connectors	Inspect for loose wiring / connectors, tighten as needed	M
Air lines / Valves / Cylinders	Inspect for loose air lines, listen for leaks, tighten, or replace poly tubing as needed	M
Compartments / Covers	Remove all covers, clean, and blow out compartments with compressed air to remove dust and dirt	M
Side-plates	Clean and wipe down with lightweight oil (based upon environmental humidity conditions)	M
Drive belt	Inspect for wear / fraying, replace if needed	M
Drive belt (right panel)	Inspect for looseness, tighten as required	M
Touch screen cabinet / arms	Tighten set screws	M
Height adjustments screws	Tighten bolts	M

CAUTION: *Unplug power cord and disconnect air line prior to removing guards, funnels, or covers. Preventative maintenance must be performed by qualified maintenance personnel.*

Legend for Preventative Maintenance Checklist:

D	Daily
W	Weekly
M	Monthly

4.16 Scheduled Maintenance Chart

ITEM	DESCRIPTION	1	2	3	4	5	6	7	8	9	10
Drive belt (right panel)	Adjust/Inspect for wear replace when necessary	O	O	O	O	O	O	O	O	O	O
Heater element and wiring	Inspect for fraying, cuts, loose connections	O	O	O	O	O	O	O	O	O	O
Pressure bar assembly	Disassemble, clean, inspect springs for wear, breakage (frequency dependent on environment and product)	O		O		O		O		O	
Guide rollers	Inspect for free movement	O	O	O	O	O	O	O	O	O	O
Roller bearings	Inspect for free movement	O	O	O	O	O	O	O	O	O	O
Perf sensor and spring	Inspect for wear, replace when necessary		O		O		O		O		O
Upper rubber roll	Inspect for cuts, unevenness	O	O	O	O	O	O	O	O	O	O
Lower aluminum roller	Clean with alcohol, inspect for burs	O	O	O	O	O	O	O	O	O	O
Printed circuit boards	Blow off with clean, dry air, inspect for loose wires, connectors	O	O	O	O	O	O	O	O	O	O
Main Seal Cylinder	Listen for air leakage, replace or repair as required	O	O	O	O	O	O	O	O	O	O
Air (blower) filter	Inspect for contamination, replace as necessary	O	O	O	O	O	O	O	O	O	O
Air lines and connectors	Inspect for wear, cuts, leaking, replace as required	O	O	O	O	O	O	O	O	O	O
	INITIALS										

Note: Each chart change represents IMM cycles

4.17 Preventative Maintenance Chart

(Options / Auxiliary Equipment)

ITEM	DESCRIPTION	1	2	3	4	5	6	7	8	9	10
	Inspected by: (Initials)										

Note: Each chart change represents IMM cycles

4.18 Spare Parts Kits

This section provides two lists of common wear items that may require occasional replacement.

Level One Spare Parts Kit

P/N: TO-T1-SP10-S14

ITEM	ITEM NO.	DESCRIPTION	QTY
1	TP-215200	SWITCH, MAGNETIC (THREADED BOLT & NUT)	1
2	TP-T1MA00115	BRAKE TENSION STRAP (DANCER)	1
3	TP-108155	COMPRESSION SPRING, PRESSURE BAR	2
4	TP-111010	COLLARS, SPRING CLOSURE (WEB GUIDE)	4
5	TP-207344	FUSE, 12 AMP, TIME DELAY	2
6	TP-217116	HEATER CARTRIDGE	1
7	TP-221416	THERMOCOUPLE WIRE W/ CONNECTOR	1
8	TP-300500-1	PTFE SHEET	1
9	TP-306002	SEAL RUBBER STRIP, T-1000	1
10	TP-404266	POLY TUBING, 1/4" DIA. BLUE (33M ROLL)	10 ft.
11	TP-404267	POLY TUBING, 3/8" OD DIA. BLUE (20M/ROLL)	5 ft.
12	TP-406181	FILTER, 4 MICRON (AIR KNIFE)	1
13	TP-502104	BELT, 210XL037	1
14	TP-101131	NUT, ACORN, BRASS NICKEL-PLATED (1/4-20)	2
15	TP-107160	BUSHING, 3/8" PTFE COATED	4
16	TA-T1-00124-1	PERF SENSOR, HIGH VOLTAGE	1

Level Two Spare Parts Kit

P/N: TO-T1-SP20-S14

ITEM	ITEM NO.	DESCRIPTION	QTY
1	TP-101131	NUT, ACORN BRASS NICKEL PLATED	2
2	TP-108155	COMPRESSION SPRING, PRESSURE BAR	2
3	TP-108156	EXTENSION SPRING, PTFE ROD ASSEMBLY	2
4	TP-111010	COLLARS, SPRING CLOSURE (WEB GUIDE)	4
5	TP-207344	FUSE, 12 AMP, TIME DELAY	2
6	TP-215200	SWITCH, MAGNETIC (THREADED BOLT & NUT)	1
7	TP-217116	HEATER CARTRIDGE, 110V/800W	1
8	TP-221416	THERMOCOUPLE WIRE W/ CONNECTOR	1
9	TP-300500-1	PTFE SHEET	1
10	TP-306002	SEAL RUBBER STRIP, T-1000	1
11	TP-404266	POLY TUBING, 1/4" DIA. BLUE (33M ROLL)	5 ft.
12	TP-404267	POLY TUBING, 3/8" OD DIA. BLUE (20M/ROLL)	5 ft.
13	TP-406181	FILTER, 4 MICRON (AIR KNIFE)	1
14	TP-502104	BELT, 210XL037	1
15	TP-T1MA00115	BRAKE TENSION STRAP (DANCER)	1
16	TA-T1-00124-1	PERF SENSOR, HIGH VOLTAGE	1
17	TP-107160	BUSHING, 3/8" PTFE COATED	4
18	TP-T1MB00033	SEAL ROD (2/M)	2
19	TP-T1ME00209	SEAL BAR COILED CABLE HARNESS	1
20	TP-T1MC00017	VULCANIZED RUBBER ROLLER	1
21	TP-501170	MOTOR, VEXTA STEPPER (NBO, S-14)	1
22	TP-T1ME00301	PCB, H. V. BOARD (FINISHED)	1
23	TP-211386	TRANSFORMER, DUAL VOLTAGE, 2400 VOLTS	1
24	TP-214111	BATTERY FOR FP SIGMA PLC	1
25	TP-215000	RELAY, SOLID STATE 10A G-SERIES	1
26	TP-501169-1	DRIVER, VEXTA 5-PHASE	1
27	TP-403244	CYLINDER, NCQ2A40-125-DUQ01760 T-1000 (SEAL CYLINDER)	1
28	TP-T1MB00111	RUBBER STRIP HOLDER	1
29	TP-403245	CYLINDER, 25MM BORE X 10MM STROKE	1
30	TP-T1MB00008	HEATER BAR MTG. PLATE	1
31	TP-T1MB00010	TIE BAR, T-1000 SEAL BAR	1
32	TP-104210	SPACER, NYLON- 1/4" X 1/2" X 3/8" LONG	2
33	TP-107160	BUSHING, 3/8" PTFE COATED	4

4.19 Troubleshooting Guide

The items included in this section cover the common causes of trouble that an operator might encounter during the operation of the T-1000-S14. When operating difficulties occur, the best procedure is to observe what is happening, identify the causes and effect the correction. Make only one adjustment at a time, checking the results of each adjustment. If an adjustment does not help or escalates the problem(s), return the settings back to the former position.

CAUTION: *These tests and repairs should be performed only by qualified mechanics or electricians and at their own risk.*

Note: *When troubleshooting a T-1000-S14 functioning within a system (i.e. with conveyors, scales, feeders, counters, etc.), always isolate the equipment and operate each machine individually.*

4.20 Troubleshooting Checklist

PROBLEM	POSSIBLE CAUSE	CORRECTIVE ACTION
60 Day Trial Expired screen appears	60 Day Trial expired	Call APPI Service
Bags not tearing off	1. Continuous Strip is ON 2. Reverse Distance is too low 3. Reverse Speed too low	1. Turn Continuous Strip OFF 2. Increase Reverse Distance 3. Increase Reverse Speed
Low Battery screen appears	It is recommended to replace battery once every three years.	If the Low Battery Screen displays on the touch screen, DO NOT turn off the machine, it will erase the operating program and any stored settings. Call APPI Service to reorder battery and for replacement instructions.
Touch screen does not display	1. Power off 2. Loose connection 3. Fuse blown 4. Contrast out of adjustment	1. Plug in power cord / turn on 2. Tighten connections 3. Replace fuse(s) 4. Adjust screen contrast
No main power light	1. Blown fuse 2. Bulb out	1. Replace fuse 2. Replace bulb
Pressure bar does not move when foot switch is operated	1. Disconnected air line/foot switch 2. Power off	1. Hookup air line 2. Turn on power
Pressure bar moves inward but does not reach the front plate (retracts immediately)	1. Anti-jam improperly adjusted 2. Misalignment of guide rods 3. Insufficient air pressure 4. Loose / broken ground wire on guide rods	1. Adjust anti-jam (section 4.12) 2. Align guide rods (section 4.6) 3. Increase air pressure 4. Connect / tighten ground wires

PROBLEM	POSSIBLE CAUSE	CORRECTIVE ACTION
Pressure bar presses against front plate but does not seal bag	<ol style="list-style-type: none"> 1. Seal time too low 2. Heat (temperature) too low 3. Heater cartridge bad 4. Insufficient air pressure 5. Misalignment of guide rods 6. PTFE folded over 7. Heater bar not extending 8. Seal cylinder bad 9. Heater bar cylinder(s) bad 	<ol style="list-style-type: none"> 1. Increase in Settings screen 2. Increase in Settings screen 3. Replace heater cartridge 4. Increase air pressure 5. Align guide rods 6. Turn PTFE 7. Check heater bar cylinders / valve 8. Replace cylinder / valve 9. Replace cylinder / valve
Bag sticks to PTFE or pressure (rubber) bar	<ol style="list-style-type: none"> 1. Seal temperature too high 	<ol style="list-style-type: none"> 1. Decrease temp in Settings screen
	<ol style="list-style-type: none"> 2. Seal time too high 3. PTFE in poor condition 4. Rubber is dirty / contaminated 	<ol style="list-style-type: none"> 2. Decrease seal time in Settings screen 3. Turn / replace PTFE 4. Clean / replace pressure bar rubber
Bag does not tear off completely	<ol style="list-style-type: none"> 1. Bag slipping through rollers 2. Compression pressure insufficient 3. Drive roller not reversing 4. Bag did not index properly 5. Seal rubber dirty / worn 	<ol style="list-style-type: none"> 1. Clean upper and lower rollers with alcohol to remove slip and dirt build-up 2. Adjust roller compression 3. Check Reverse setting 4. Index another bag for test 5. Clean / replace rubber
Two bags index from rollers	<ol style="list-style-type: none"> 1. Bag is folded over 2. Perf sensor dirty / damaged 3. Perf sensitivity out of adjustment 4. Ungrounded outlet causing electrical noise 5. Auxiliary equipment: noise 6. Seal point value too high 	<ol style="list-style-type: none"> 1. Lower inner frame and straighten bag 2. Clean / replace perf sensor 3. Contact APPI for perf adjustment 4. Plug into "clean" power source 5. Contact APPI for solution 6. Set value lower
Bag does not completely index	<ol style="list-style-type: none"> 1. Perf is sensing hole in bag (vent) 2. Seal position setting too low 	<ol style="list-style-type: none"> 1. Reposition bag 2. Increase seal position in Settings screen
Bag web indexing to floor level without stopping on bag	<ol style="list-style-type: none"> 1. Perf sensor not sensing bag 2. Dirty / damaged sensor 3. Perf sensor out of adjustment 	<ol style="list-style-type: none"> 1. Contact APPI for adjustment 2. Clean / replace sensor 3. Contact APPI for adjustment
Bags web breaking prematurely in machine	<ol style="list-style-type: none"> 1. Improper web tension 2. Web dragging foreign objects 3. Bag roll side plates bent inward 	<ol style="list-style-type: none"> 1. Adjust tension 2. Remove obstructions 3. Repair / remove side-plates

4.21 PLC IO Listing

Main PLC and Expansion PLC IO (Inputs and Outputs) listing is provided to assist in troubleshooting the T-1000-S14.

Card:	Address		Description	Normal State
Inputs				
Main PLC	X	0	Reserved for Stepper control	NA
Main PLC	X	1	Perf Sensor	off
Main PLC	X	2	Not Used - Available	
Main PLC	X	3	AF10 Home Sensor	off
Main PLC	X	4	Jam Detect Sensor	on
Main PLC	X	5	CF-10 Part Counting Eye	off
Main PLC	X	6	Auxiliary In	off
Main PLC	X	7	Seal Bar In Sensor	off
Main PLC	X	8	Foot switch (Pick-to-Light Touch)	off
Main PLC	X	9	Out of Bags Sensor	off
Main PLC	X	A	Frame Open Sensor	on
Main PLC	X	B	TI1k Printer Ready	off
Main PLC	X	C	TI1k Printer Error	off
Main PLC	X	D	Palm Button Left	off
Main PLC	X	E	Palm Button Right	off
Main PLC	X	F	Aux Fault	off
Main PLC	X	10	Not Used - Not Available	
Main PLC	X	11	Not Used - Not Available	
Main PLC	X	12	Not Used - Not Available	
Main PLC	X	13	Not Used - Not Available	
Main PLC	X	14	Not Used - Not Available	
Main PLC	X	15	Not Used - Not Available	
Main PLC	X	16	Not Used - Not Available	
Main PLC	X	17	Not Used - Not Available	
Main PLC	X	18	Not Used - Not Available	
Main PLC	X	19	Not Used - Not Available	
Main PLC	X	1A	Not Used - Not Available	
Main PLC	X	1B	Not Used - Not Available	
Main PLC	X	1C	Not Used - Not Available	
Main PLC	X	1D	Not Used - Not Available	
Main PLC	X	1E	Not Used - Not Available	
Main PLC	X	1F	Not Used - Not Available	
PLC Exp1	X	20	UF5k Flight Sensor	off
PLC Exp1	X	21	UF5k Part Sensor	off
PLC Exp1	X	22	UF5k Drive alarm	on
PLC Exp1	X	23	Not Used - Available	off
PLC Exp1	X	24	ESTOP	off

PLC Exp1	X	25	Light Curtain signal	on
PLC Exp1	X	26	DF-20 Eye	off
PLC Exp1	X	27	Barcode 'Quality Error'	off
PLC Exp1	X	28	US50: Tray Home sensor	on
PLC Exp1	X	29	US50: Tray Out sensor	off
PLC Exp1	X	2A	MV10 Temperature alarm	off
PLC Exp1	X	2B	MV10 Pressure alarm	off
PLC Exp1	X	2C	Barcode 'GOOD READ'	off
PLC Exp1	X	2D	BO-30 Bag Open sensor	off
PLC Exp1	X	2E	BO30: Home sensor	on
PLC Exp1	X	2F	Barcode 'NO READ'	off
PLC Exp1	X	30	Not Used - Not Available	
PLC Exp1	X	31	Not Used - Not Available	
PLC Exp1	X	32	Not Used - Not Available	
PLC Exp1	X	33	Not Used - Not Available	
PLC Exp1	X	34	Not Used - Not Available	
PLC Exp1	X	35	Not Used - Not Available	
PLC Exp1	X	36	Not Used - Not Available	
PLC Exp1	X	37	Not Used - Not Available	
PLC Exp1	X	38	Not Used - Not Available	
PLC Exp1	X	39	Not Used - Not Available	
PLC Exp1	X	3A	Not Used - Not Available	
PLC Exp1	X	3B	Not Used - Not Available	
PLC Exp1	X	3C	Not Used - Not Available	
PLC Exp1	X	3D	Not Used - Not Available	
PLC Exp1	X	3E	Not Used - Not Available	
PLC Exp1	X	3F	Not Used - Not Available	
PLC Exp2	WX	4	Thermocouple Input TC1	
PLC Exp2	WX	5	Input TC2: Not Used - Available	
Outputs				
Main PLC	Y	0	Stepper PulseTrain CW	
Main PLC	Y	1	Stepper PulseTrain CCW	
Main PLC	Y	2	H/V trigger	
Main PLC	Y	3	Heater control	
Main PLC	Y	4	Air Blower solenoid	
Main PLC	Y	5	Air Pulse solenoid	
Main PLC	Y	6	Heater Bar solenoid	
Main PLC	Y	7	Seal Bar Out solenoid	
Main PLC	Y	8	Seal Bar In solenoid	
Main PLC	Y	9	Blow Off solenoid	

Main PLC	Y	A	TIZ NBO Print request	
Main PLC	Y	B	Station #5 solenoid	
Main PLC	Y	C	H/V Armed (for 220V)	
Main PLC	Y	D	LC-10 Power relay	
Main PLC	Y	E	TIZ INL Print request	
Main PLC	Y	F	Auxiliary Out	
Main PLC	Y	10	Not Used - Not Available	
Main PLC	Y	11	Not Used - Not Available	
Main PLC	Y	12	Not Used - Not Available	
Main PLC	Y	13	Not Used - Not Available	
Main PLC	Y	14	Not Used - Not Available	
Main PLC	Y	15	Not Used - Not Available	
Main PLC	Y	16	Not Used - Not Available	
Main PLC	Y	17	Not Used - Not Available	
Main PLC	Y	18	Not Used - Not Available	
Main PLC	Y	19	Not Used - Not Available	
Main PLC	Y	1A	Not Used - Not Available	
Main PLC	Y	1B	Not Used - Not Available	
Main PLC	Y	1C	Not Used - Not Available	
Main PLC	Y	1D	Not Used - Not Available	
Main PLC	Y	1E	Not Used - Not Available	
Main PLC	Y	1F	Not Used - Not Available	
PLC Exp1	Y	20	UF5k Run	
PLC Exp1	Y	21	Not Used - Available	
PLC Exp1	Y	22	Barcode Read trigger	
PLC Exp1	Y	23	Not Used - Available	
PLC Exp1	Y	24	US-5000 Flip solenoid	
PLC Exp1	Y	25	Stack Light Red	
PLC Exp1	Y	26	Stack Light Yellow	
PLC Exp1	Y	27	Stack Light Green	
PLC Exp1	Y	28	Station #6 solenoid	
PLC Exp1	Y	29	Station #7 solenoid	
PLC Exp1	Y	2A	Station #8 solenoid	
PLC Exp1	Y	2B	Station #9 solenoid	
PLC Exp1	Y	2C	Station #10 solenoid	
PLC Exp1	Y	2D	Stand Adjust: Bagger UP	
PLC Exp1	Y	2E	Stand Adjust: Bagger DOWN	
PLC Exp1	Y	2F	UF5k: Drive Alarm reset	
PLC Exp1	Y	30	Not Used - Not Available	
PLC Exp1	Y	31	Not Used - Not Available	
PLC Exp1	Y	32	Not Used - Not Available	
PLC Exp1	Y	33	Not Used - Not Available	

PLC Exp1	Y	34	Not Used - Not Available	
PLC Exp1	Y	35	Not Used - Not Available	
PLC Exp1	Y	36	Not Used - Not Available	
PLC Exp1	Y	37	Not Used - Not Available	
PLC Exp1	Y	38	Not Used - Not Available	
PLC Exp1	Y	39	Not Used - Not Available	
PLC Exp1	Y	3A	Not Used - Not Available	
PLC Exp1	Y	3B	Not Used - Not Available	
PLC Exp1	Y	3C	Not Used - Not Available	
PLC Exp1	Y	3D	Not Used - Not Available	
PLC Exp1	Y	3E	Not Used - Not Available	
PLC Exp1	Y	3F	Not Used - Not Available	
PLC Exp2	WY	4	Analog Output - UF5k: Conveyor speed	

4.22 Schematics

Electrical and Pneumatic drawings are provided along with descriptions to assist in troubleshooting the T-1000-S14.

A. Electrical Drawings

110V Circuit

Circuit drawings are provided to assist in troubleshooting the functionality of the T-1000 and the interface signaling with auxiliary infeed equipment.

A circuit diagram of the 110V circuit is comprised of main power to the T-1000, through the fuse, Corcom filter, motor controller, solid state relay, heater element, line out, and into the power supply printed circuit board. See Dwg T1kST-E1_110VAC.

Thermocouple Expansion Card, Heater Circuit

A circuit diagram of the Thermocouple Expansion controller TC4 with correct DIP switch settings is provided. See Dwg T1kST-E56_TC4.

Analog Output Card

A circuit diagram of the new Analog Card for UF-5000 Conveyor Speed Control. See Dwg T1KST-E57_FPORDA4.

Stepper Motor Circuit

A circuit diagram of the stepper motor controller is provided with correct DIP switch and Pot settings. See Dwg T1kST-E4.

High Voltage Board Assembly

APPI manufactures the printed circuit board for accurate and consistent perforation detection, for accurate bag positioning and registration. A circuit diagram is provided for this PCB.

Aux Interface

APPI provides for a closed loop signal with auxiliary infeed equipment. The circuit diagram references the pinouts on Aux 2 connector, located on the T-1000 rear electrical panel (military connector). See Dwg T1kST-E7.

Solenoid Valve Circuit Diagram

The T-1000 is equipped with an expandable Valve manifold, pre-wired for up to 7 options solenoid valves. Valve stations 1 through 4 are standard, and valve station 5-11 are options. PLC output information, DB25 pinouts, voltages and valve descriptions are provided on this circuit diagram. See Dwg T1kST-E8.

PLC Expansion Inputs and Outputs

The T-1000 comes equipped with a PLC Expansion, where standard options are wired into the bagger. See T1kST-E10_EXP-IO.

DB connector circuit drawing

T1kST-E14_DBCon

Panasonic Light Curtain SF4C

The T-1000 has the option of having a light curtain installed as an extra safety measure. See T1kST-E34_LC_Panasonic SF4C.

Barcode Verifier

The T-1000-S14 has the option of a Barcode Verifier installed to scan labels. See T1kST-E35_BCV_Keyence SR.

110V Circuit

T1kST-E1-110VAC

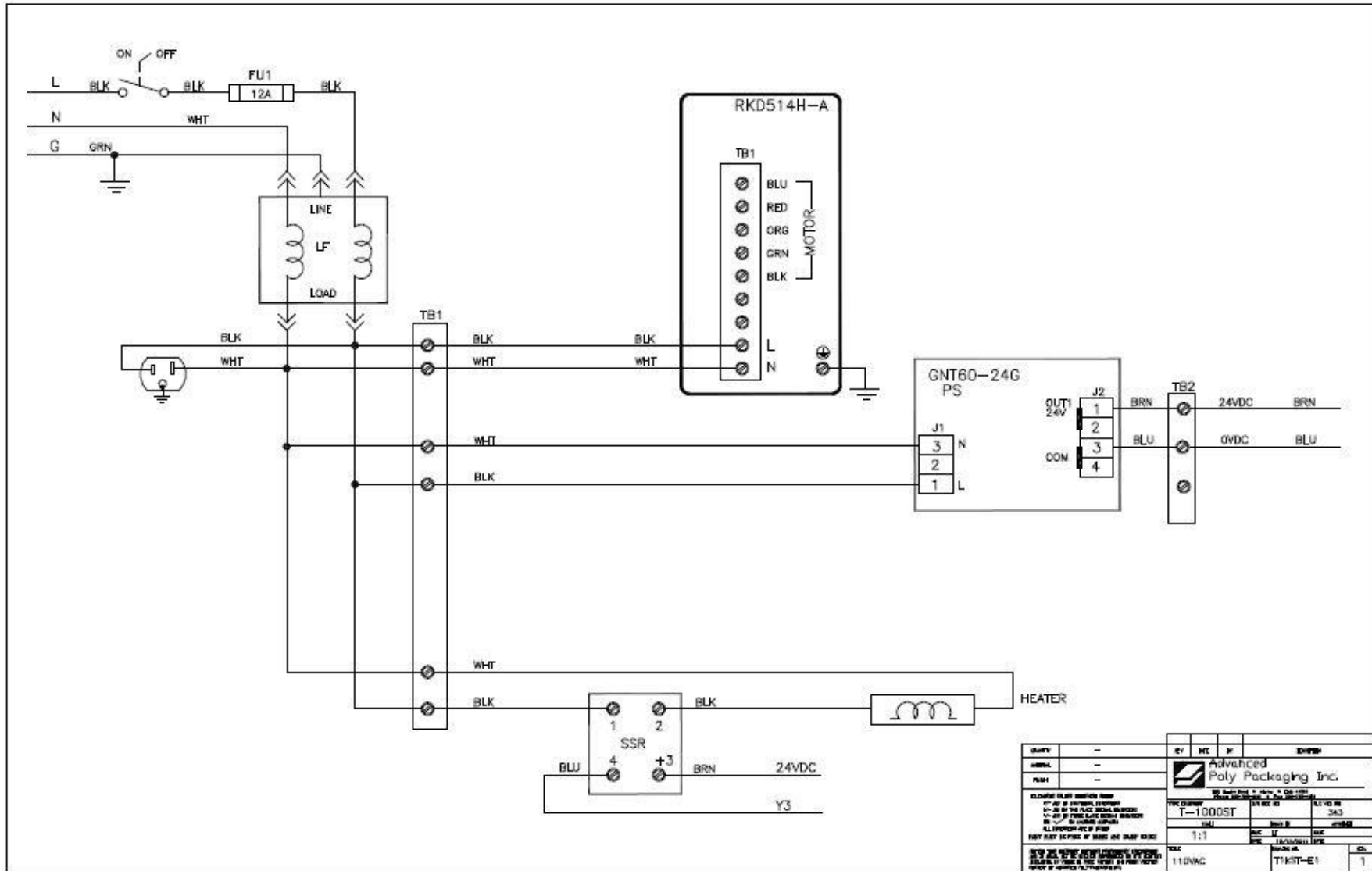

QTY	-	REV	REV	REV	REV
APP	-	 Advanced Poly Packaging Inc.			
PSN	-				
<small> ALL DIMENSIONS UNLESS OTHERWISE SPECIFIED TYP. DIMENSIONS IN INCHES UNLESS OTHERWISE SPECIFIED ALL DIMENSIONS ARE TO CENTER UNLESS OTHERWISE SPECIFIED FINISHES ARE AS SHOWN UNLESS OTHERWISE SPECIFIED DIMENSIONS ARE TO CENTER UNLESS OTHERWISE SPECIFIED DIMENSIONS ARE TO CENTER UNLESS OTHERWISE SPECIFIED </small>					
TYP. QTY	T-1000ST	REV. NO.	REV. NO.	REV. NO.	REV. NO.
SCALE	1:1	DATE	DATE	DATE	DATE
DATE	11/01/01	DATE	DATE	DATE	DATE
REV	11/01/01	REV	11/01/01	REV	11/01/01
REV	11/01/01	REV	11/01/01	REV	11/01/01

Analog Card, Temperature Controller, Heater Circuit

T1kST-E56_TC4

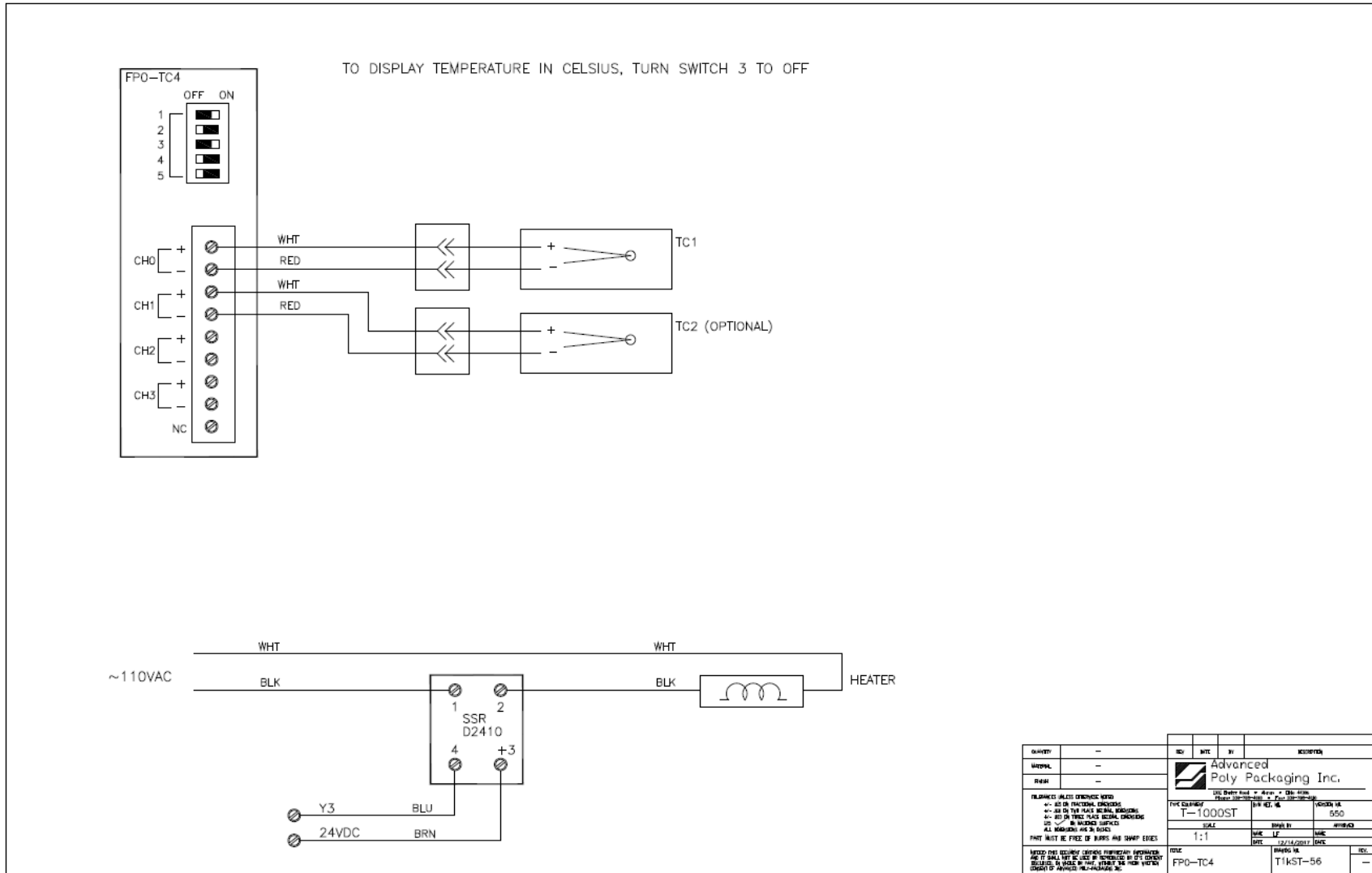

QUANTITY	—	REV	DATE	BY	REVISION
WARRANTY	—	 Advanced Poly Packaging Inc. 10000 ST. 4th Fl. St. Louis, MO 63108 Phone: (314) 431-1111 • Fax: (314) 431-1112			
REMARK	—				
DIMENSIONS: ALL IN DIMENSIONED VIEW *— ALL IN FRACTIONAL DIMENSIONS **— ALL IN THE PLACE OF THE DIMENSIONS ***— ALL IN THE PLACE OF THE DIMENSIONS ****— IN HUNDRED THOUSHS					
TYPE CHANGE T-1000ST		REV. NO. 550		DATE 12/11/2011	
SCALE 1:1		DATE 12/11/2011		DATE 12/11/2011	
PART MUST BE FREE OF BURRS AND SHARP EDGES NEED THE FOLLOWING DIMENSIONS: DIMENSIONS MEET SHALL NOT BE USED IF DIMENSIONS IN THIS DRAWING EXCEEDS IN SIZE IN THIS POINT IN THE DRAWING CONTACT ADVANCED POLY-PACKAGING INC.					
DATE	FP0-TC4	REVISED IN	T1kST-56	REV.	—

Analog Output Card

T1kST-E57_FPORDA4

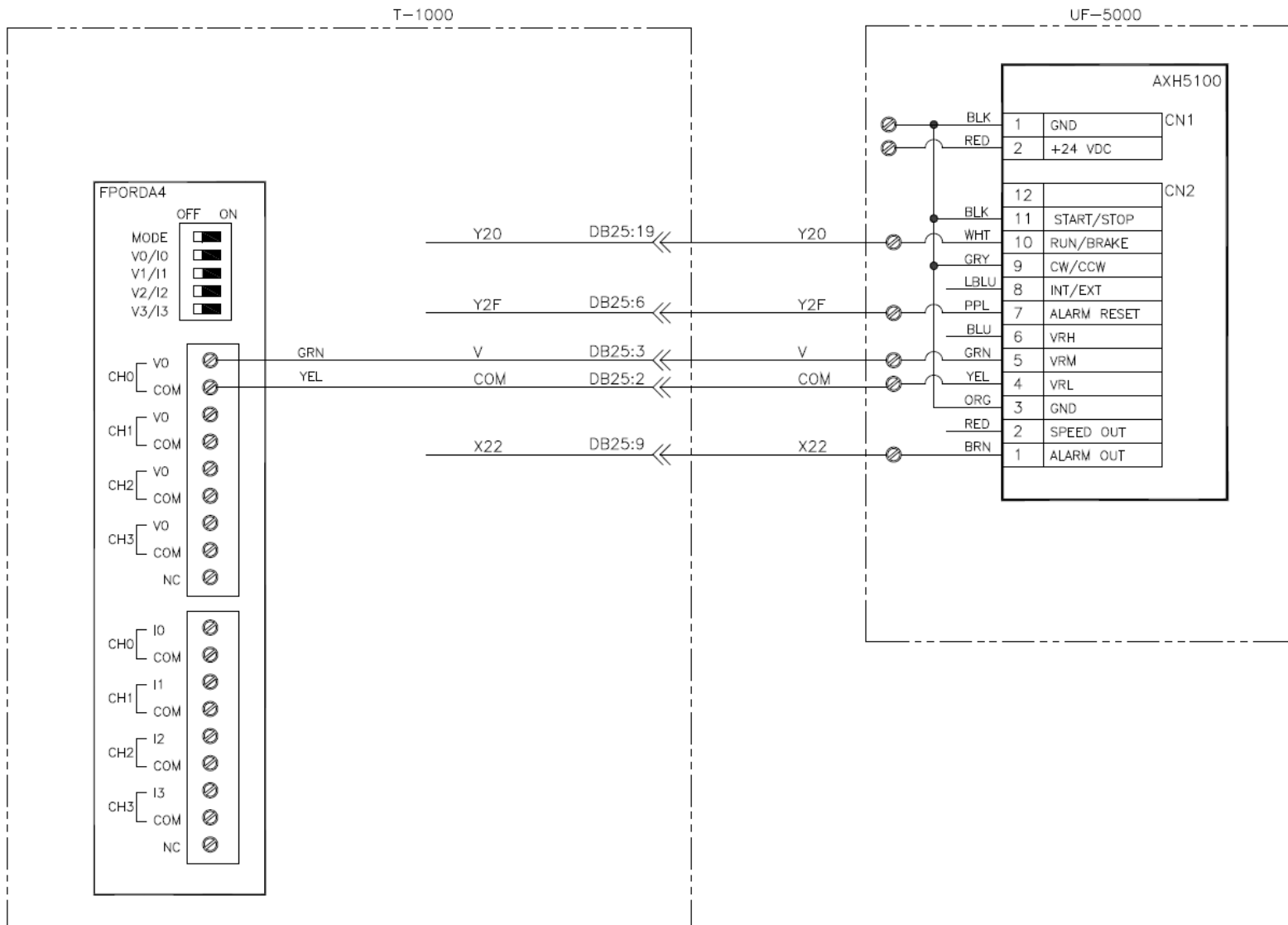

Stepper Motor Circuit

T1KST-E4

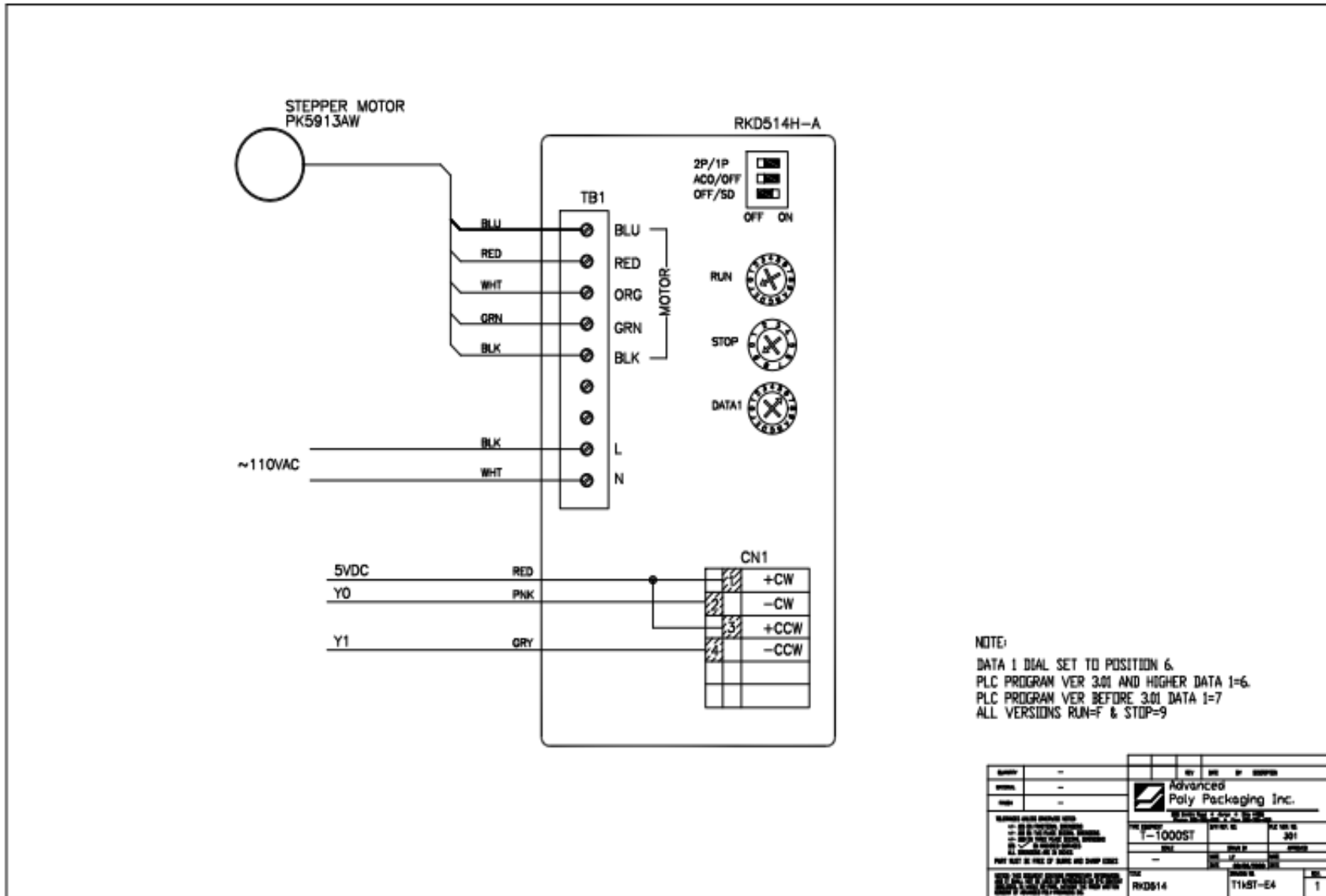

High Voltage Board Assembly

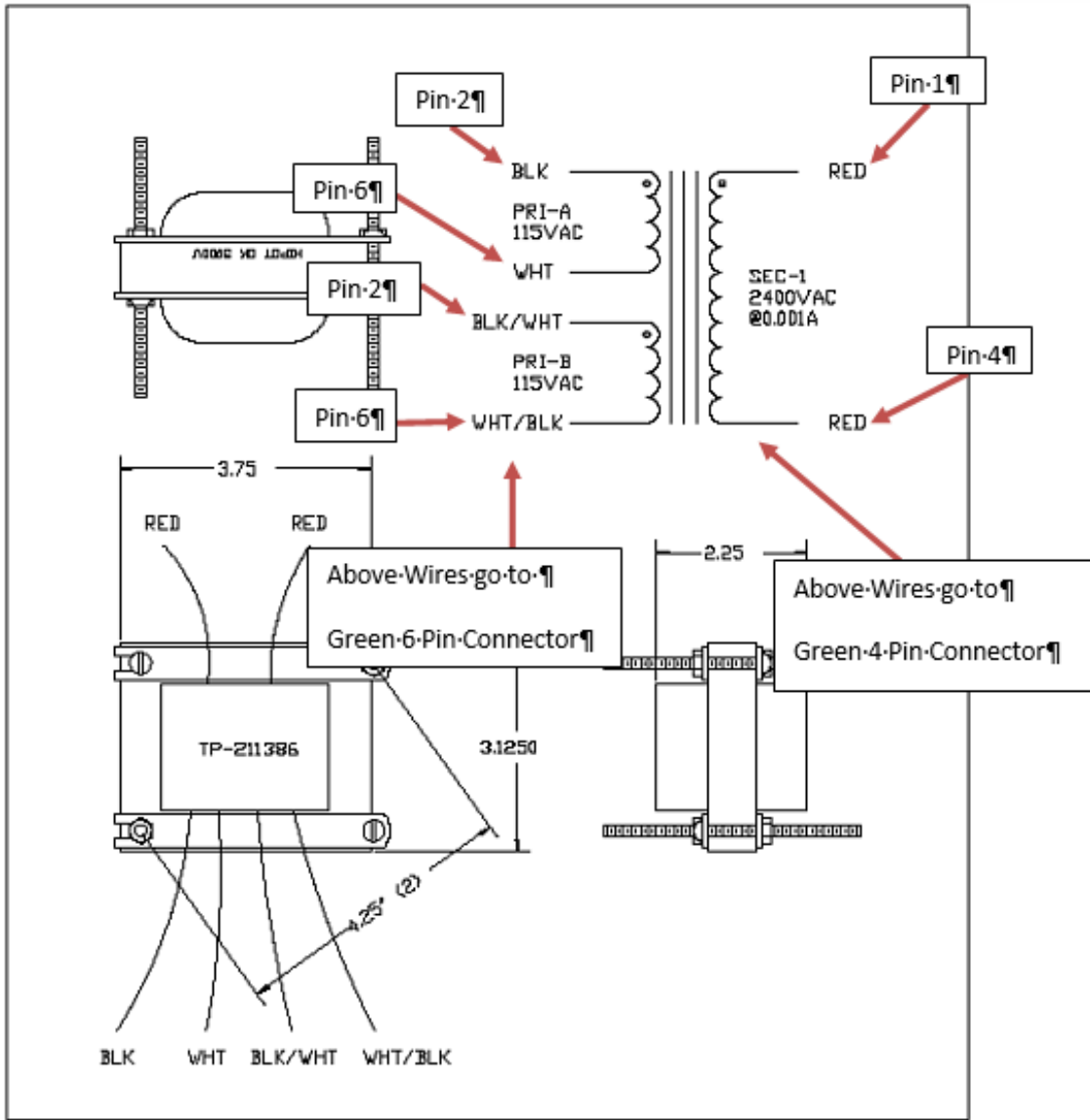

Solenoid Valve Circuit Diagram

T1KST-E8

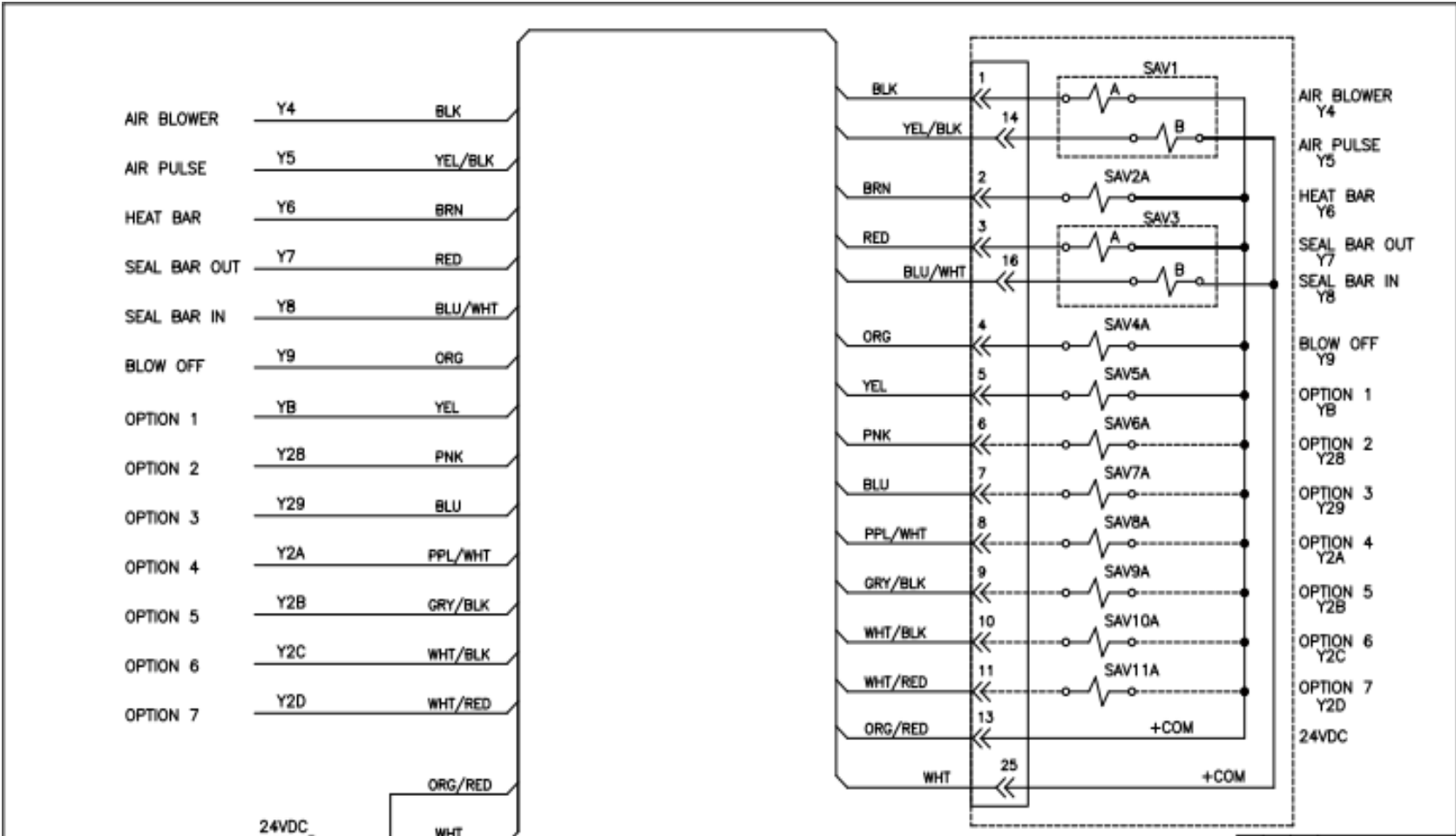

REV	DATE	BY	DESCRIPTION
1			Advanced Poly Packaging Inc.
<p>ADVANCED POLY PACKAGING INC. 10000 ST. LOUIS, MO 63143 TEL: 314-991-1111 FAX: 314-991-1112 WWW: WWW.APPACK.COM</p>			
PART NUMBER T-1000ST		REV. NO. 001	
SCALE 1:1		SHEET NO. 2	
TITLE SAV MANIFOLD (LC)		DRAWING NO. T1KST-E8	

DB Connector Pin

T1kST-E14_DBCon

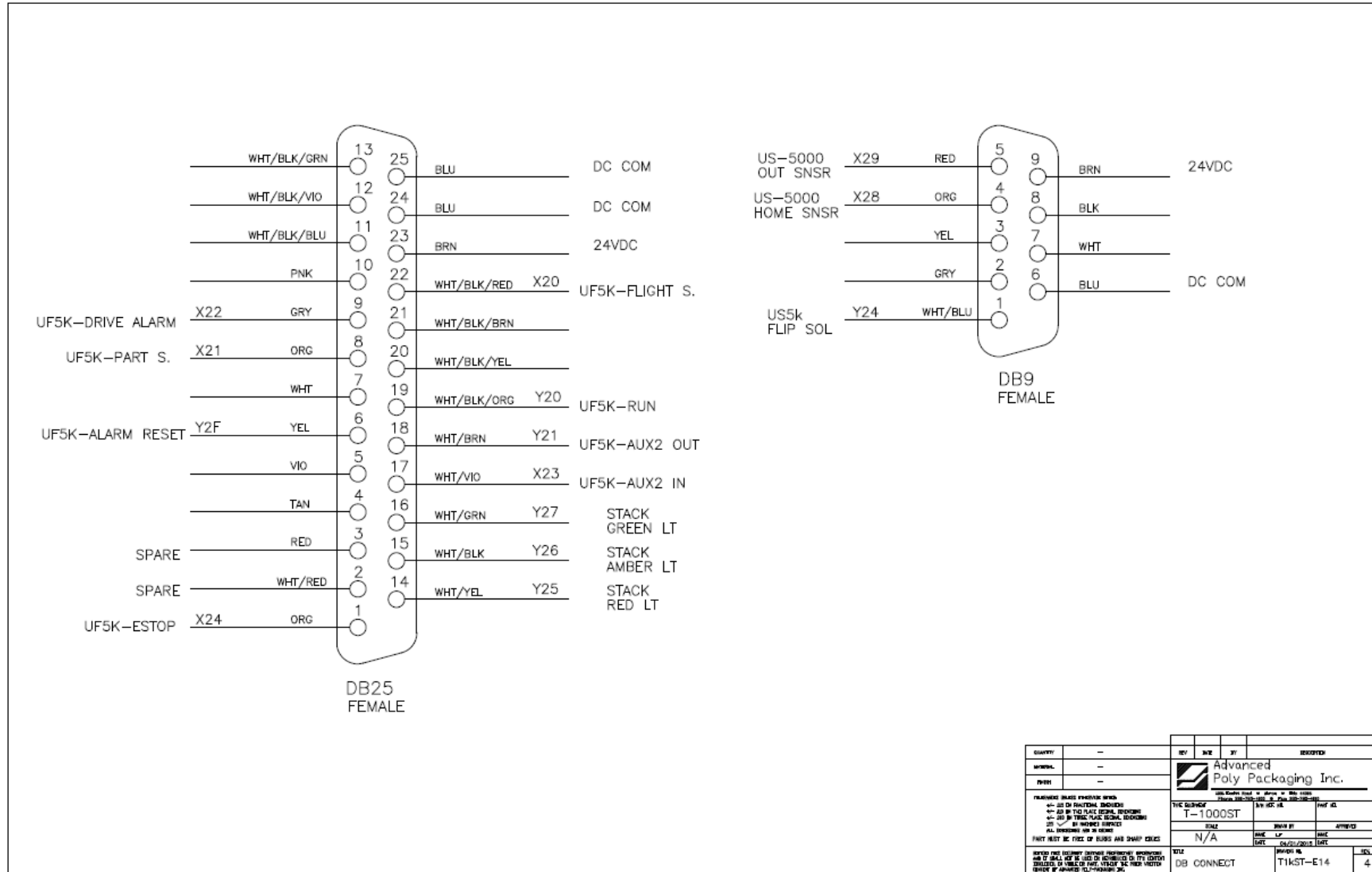

QUANTITY	-	REV	REV	REV	REV
DATE	-	Advanced Poly Packaging Inc.			
PART	-				
<small> PART NUMBER SHOWN PREVIOUS EDITIONS -+ ADD OR FUNCTIONAL CHANGES -+ ADD OR TO PLACE DESIGN REVISIONS -+ ADD OR TO PLACE DESIGN REVISIONS -+ ADD OR TO PLACE DESIGN REVISIONS ALL DIMENSIONS ARE IN INCHES PART MUST BE FREE OF BURRS AND SHARP EDGES </small>		<small> THIS DRAWING IS THE PROPERTY OF ADVANCED POLY PACKAGING INC. IT IS TO BE USED ONLY FOR THE PURPOSES SPECIFIED HEREON. IT IS NOT TO BE REPRODUCED OR TRANSMITTED IN ANY FORM OR BY ANY MEANS, ELECTRONIC OR MECHANICAL, INCLUDING PHOTOCOPYING, RECORDING, OR BY ANY INFORMATION STORAGE AND RETRIEVAL SYSTEM, WITHOUT THE WRITTEN PERMISSION OF ADVANCED POLY PACKAGING INC. </small>	<small> T-1000ST REV. 01, 08 DATE: 08/01/08 </small>	<small> DRAWN BY: JAC CHECKED BY: JAC DATE: 08/01/08 </small>	<small> TITLE: DB CONNECT PART NO.: T1KST-E14 QTY: 4 </small>

Panasonic Light Curtain

T1kST-E34_LC_Panasonic SF4C

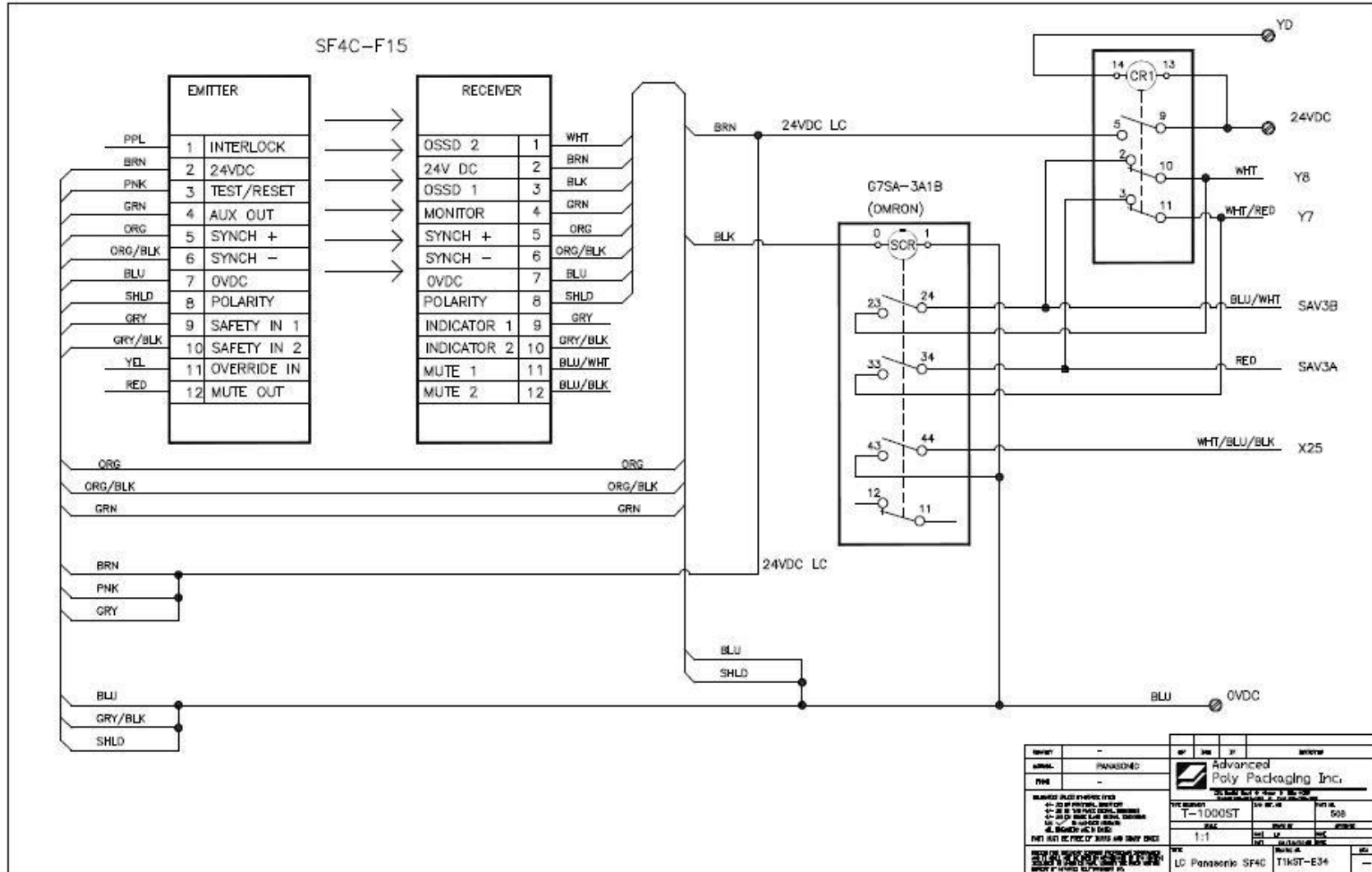

Barcode Verifier

T1kST-E35_BCV_Keyence SR

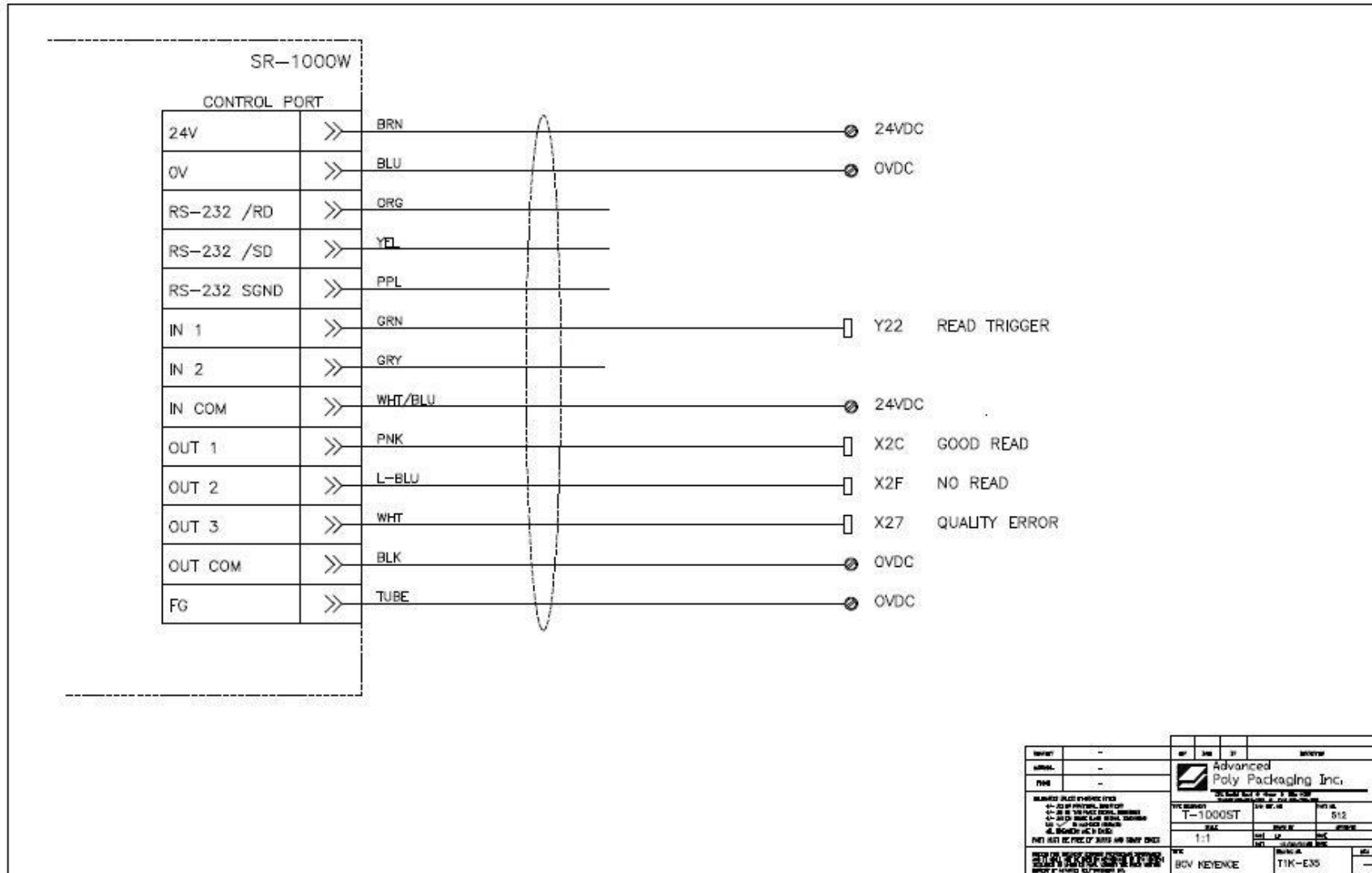

REVISED	-	REVISED	-
DATE	-	DATE	-
BY	-	BY	-
		T-1000ST 1:1 BGV KEYENCE TIK-E35	

B. Pneumatic Piping Diagrams

APPI offers a piping diagram to assist in troubleshooting the T-1000 bagger. Piping from Solenoid Valve Stations 5 through 11 will change based on the configuration of the T-1000 and the options ordered by the customer. See Dwgs T-1000 PNE 1 through 7.

T-1000 PNE 1: T-1000-S14 Pneumatic System Layout Diagram

T-1000 PNE 2: Printer Pneumatic Layout

T-1000 PNE 3: Accumulator Funnel Pneumatic Layout

T-1000 PNE 4: Load Shelf Pneumatic Layout

T-1000 PNE 5: Flat Seal Pneumatic Layout

T-1000 PNE 6: Bag Opener Pneumatic Layout

T-1000 PNE 7: Trim Seal Pneumatic Layout

T-1000-S14 Pneumatic System Layout Diagram

T-1000 PNE 1

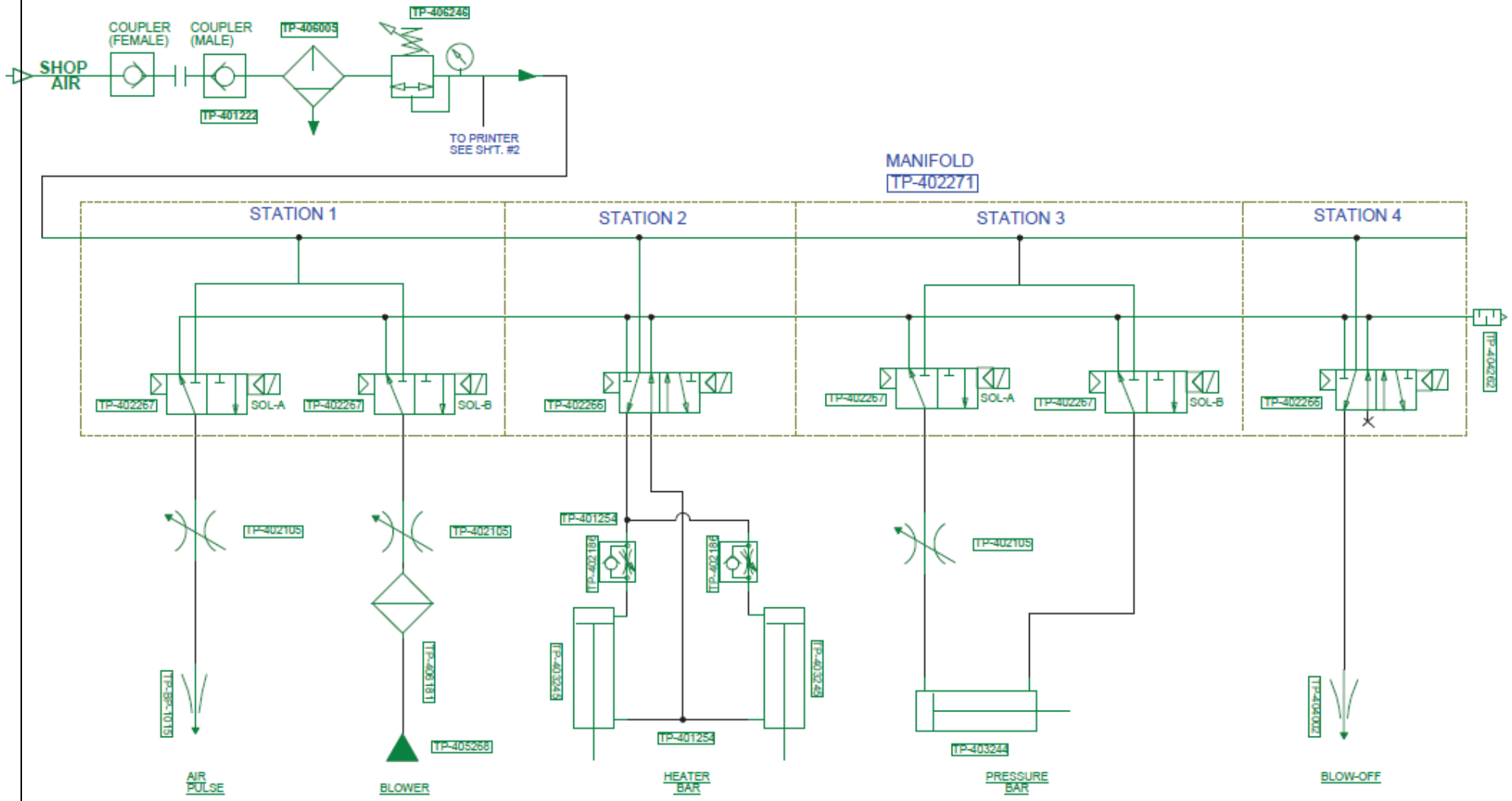

Printer Pneumatic Layout

T-1000 PNE 2

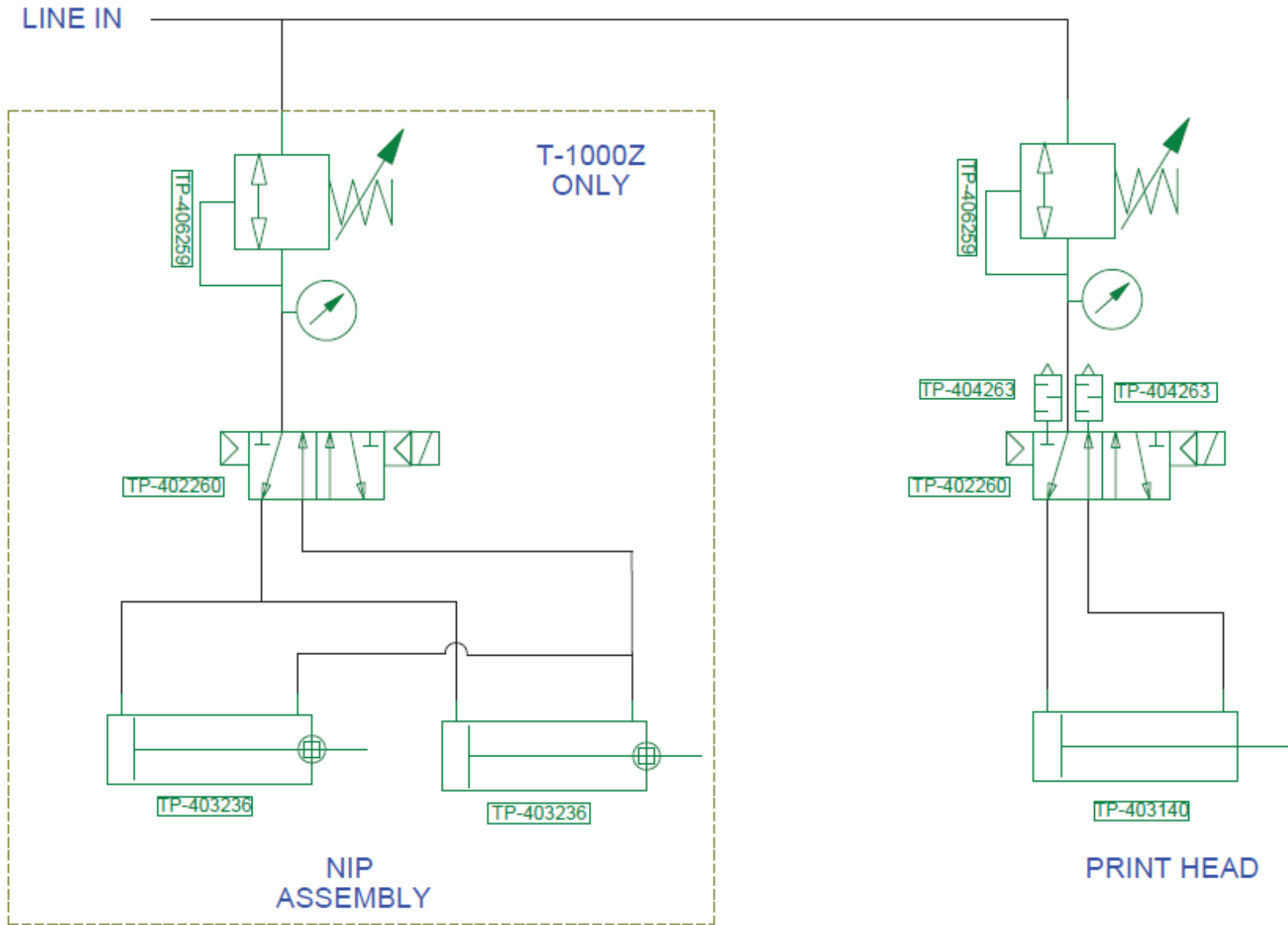

Accumulator Funnel Pneumatic Layout
T-1000 PNE 3

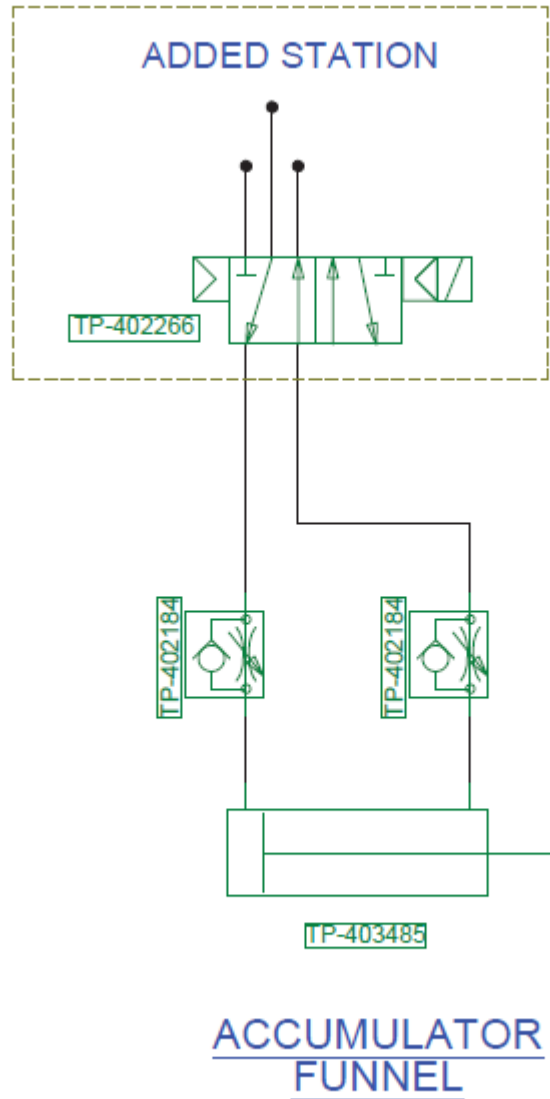

Load Shelf Pneumatic Layout

T-1000 PNE 4

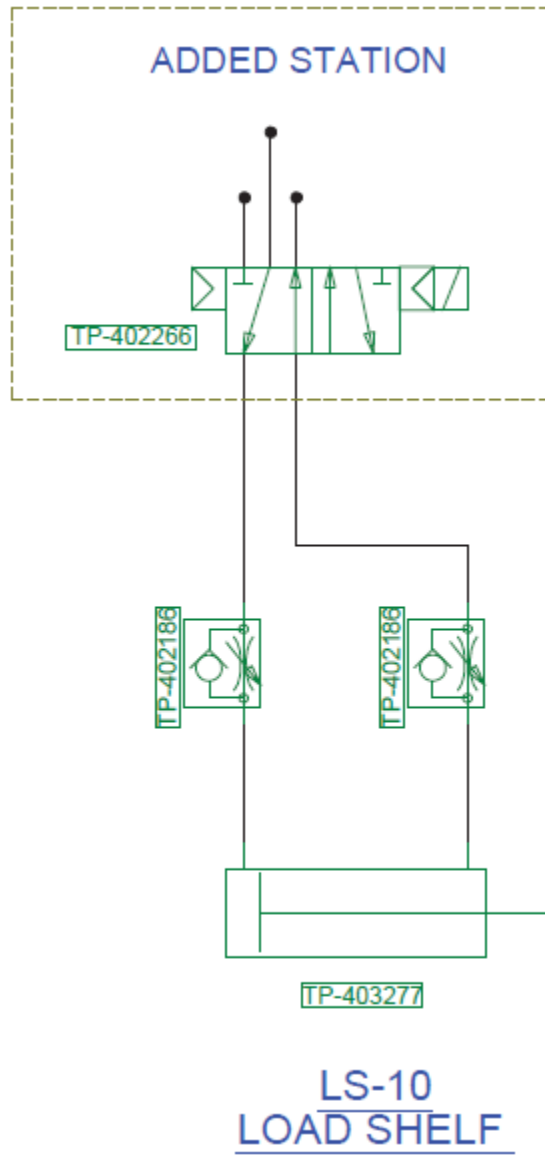

Flat Seal Pneumatic Layout

T-1000 PNE 5:

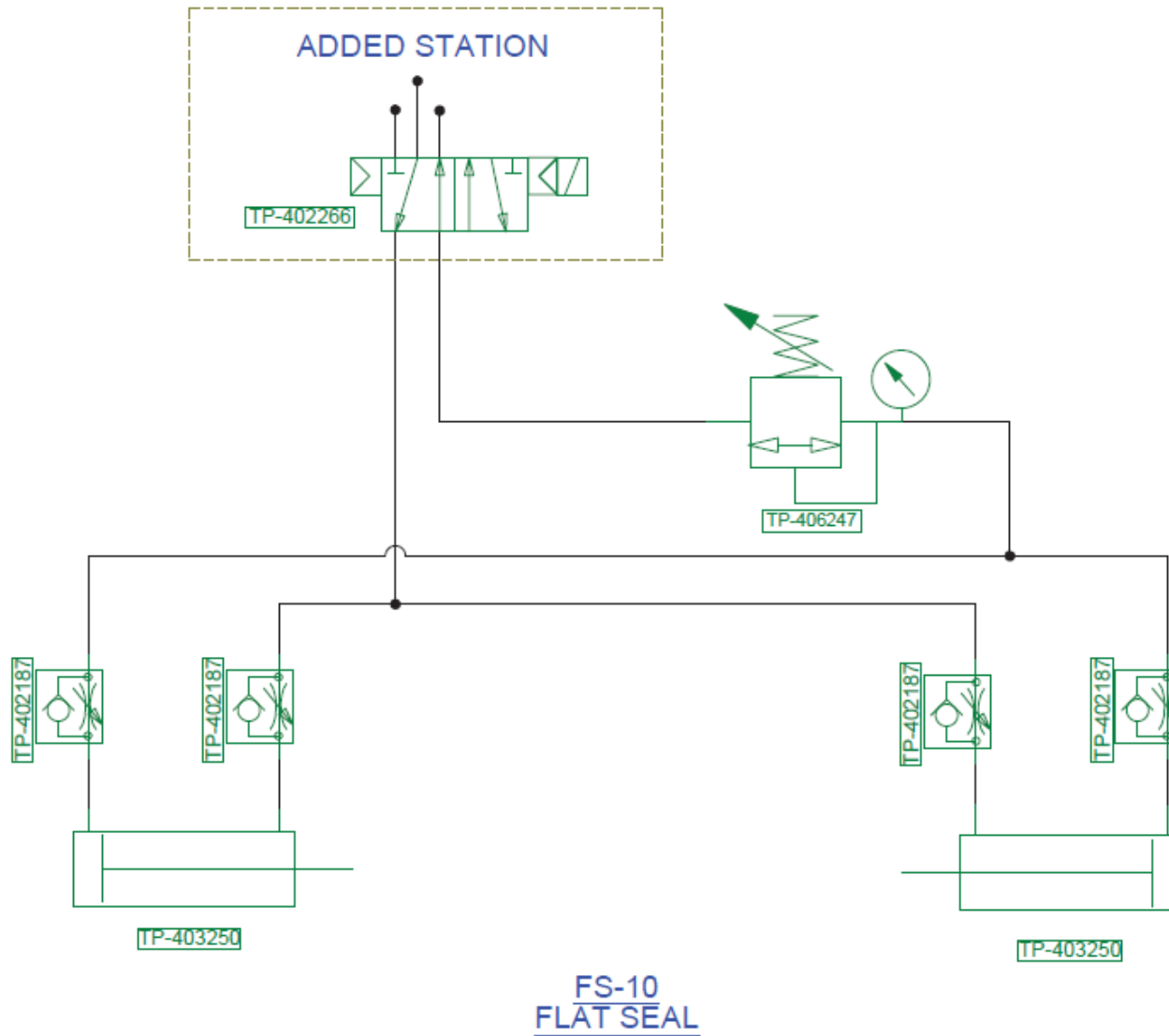

Bag Opener Pneumatic Layout

T-1000 PNE 6

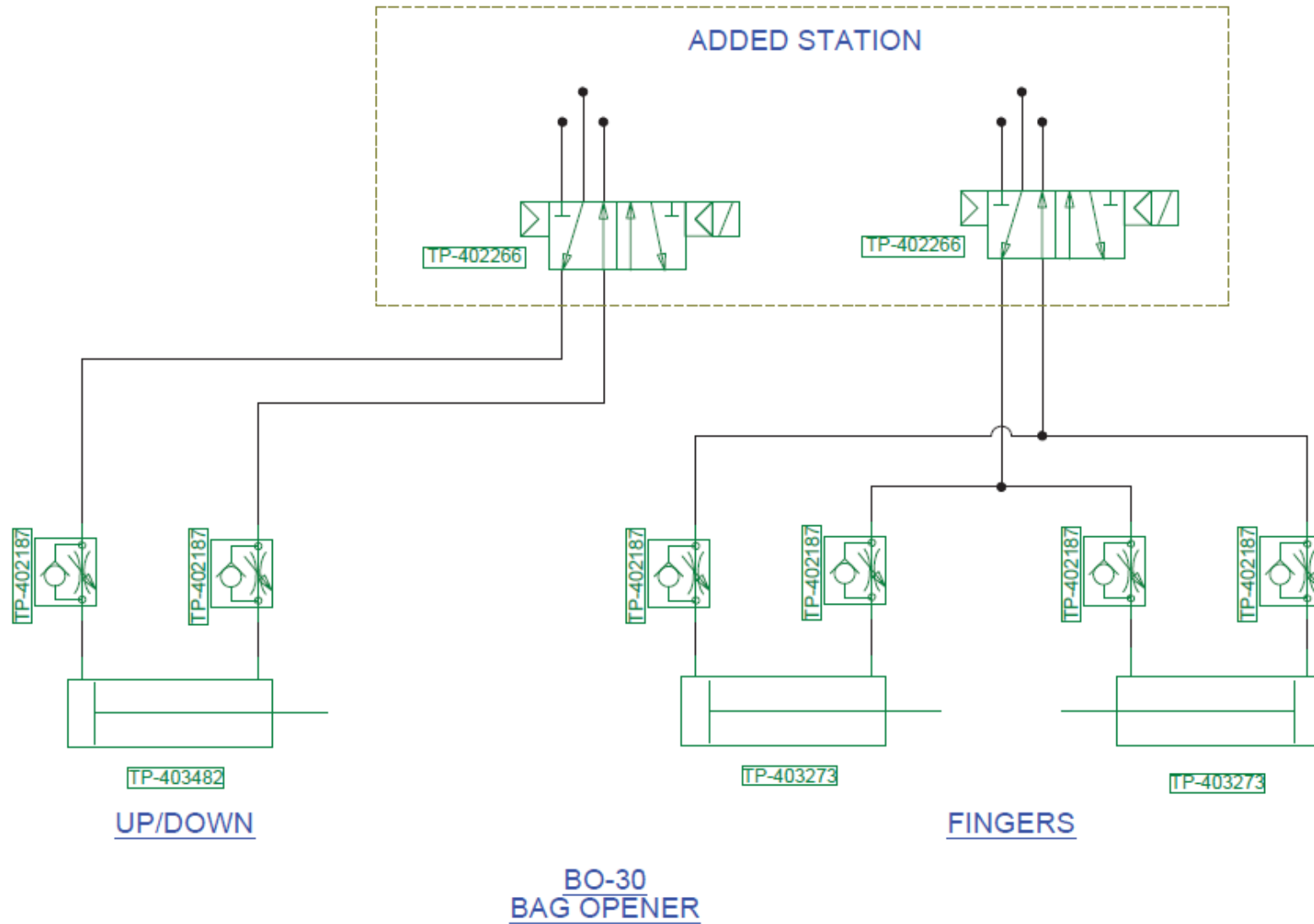

Trim Seal Pneumatic Layout

T-1000 PNE 7

NBO & TRIM SEAL ONLY

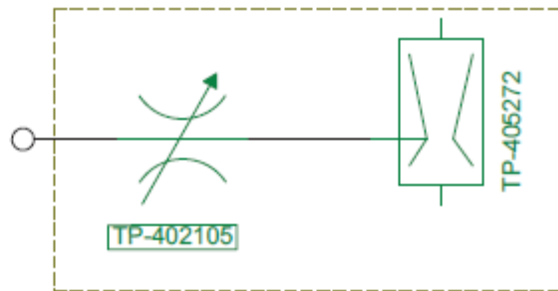

This page intentionally left blank

Chapter 5: Parts and Drawings

T-1000-S14 Advanced Poly-Bagger

Base Assembly

Upper Column Assembly

Covers and Guarding

Flat Load Shelf Assembly

Dancer Assembly

Touch Screen Assembly

Main Frame Assembly

Air Knife Assembly

Sealer Frame Assembly: Drop Frame

NBO Wide Sealer Frame Assembly: Drop Frame

Electrical Panel

Bag Blow Off (Optional)

Bag Deflator (Optional)

Notes

5.1 T-1000-S14 Advanced Poly-Bagger

T-T1000-S14

ITEM NO.	QTY.	PART NO	DESCRIPTION
1	1	TA-T10200	BASE ASSEMBLY
2	1	TA-T10210	UPPER COLUMN ASSEMBLY
3	1	TA-T10018	FLAT LOAD SHELF ASSEMBLY
4	1	TA-T10220	DANCER ASSEMBLY
5	1	TA-T10240	IOP (TOUCH SCREEN)
6	1	SEE ASSEMBLY	BAGGER W/OUT PRINTER
7	1	TA-T10250-S14	MAIN FRAME ASSEMBLY
8	1	TA-T10001-S14	AIR KNIFE ASSEMBLY
9	1	TA-T10280-S14	NBO SEAL DROP FRAME
10	1	TA-T10002-S14	UPPER ROLLER ASSEMBLY
11	1	TA-T10270-S14	ELECTRICAL PANEL
12	1	TP-T1MD00004-S14	ELECTRONICS COVER
13	1	TP-T1MD00005S14	RIGHT SIDE COVER
14	1	TP-T1MD00044	TOP COVER
15	2	TP-111241	SNAP BUTTON PLUG
16	1	SEE ASSEMBLY	LEXAN GUARD W/SIDE GUARDS

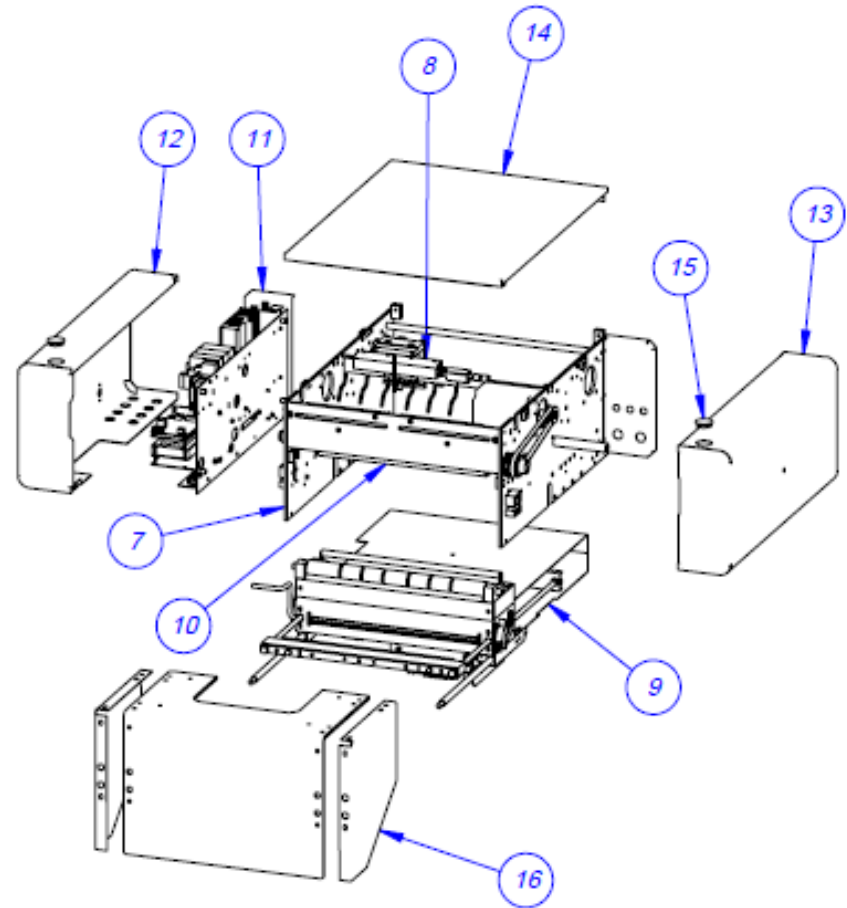
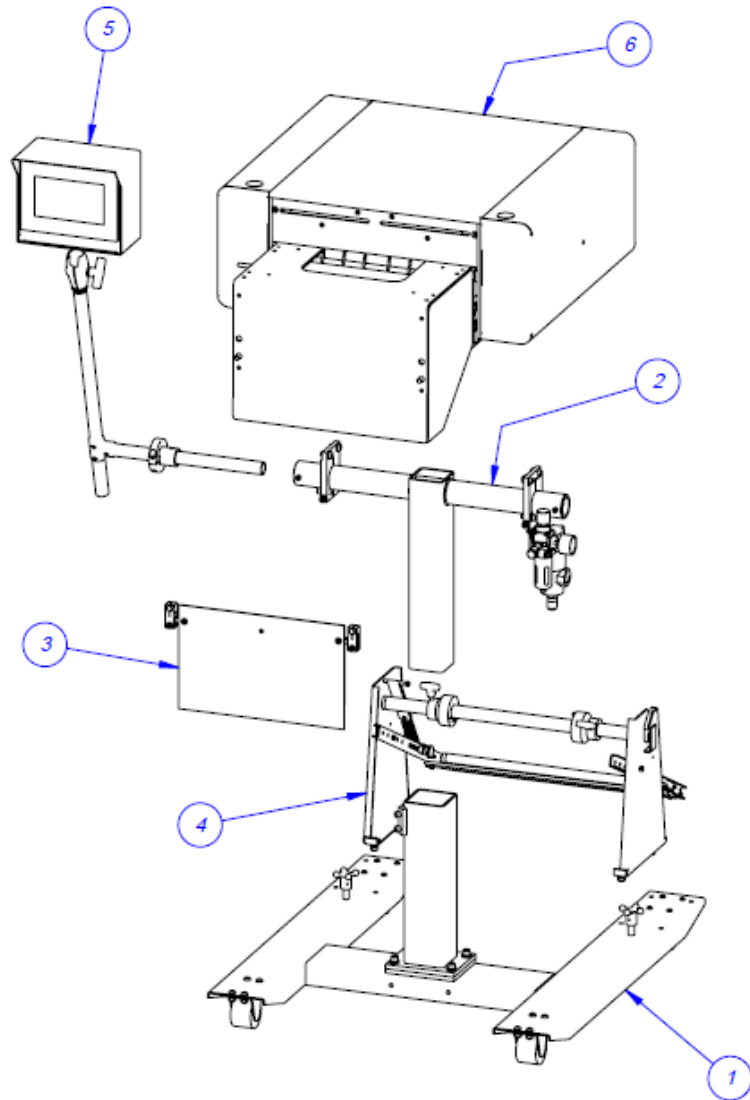

VIEW FROM INSIDE BAGGER

5.2 Base Assembly

P/N: TA-T10200

ITEM NO.	QTY.	PART NO	DESCRIPTION
1	1	TP-T1MA00051	LOWER BASE WELDMENT
2	1	TP-T1MA00051-1	LOWER COLUMN
3	2	TP-106094	STUD, FLOOR LEVELER
4	2	TP-106119	SPRING PIN
5	2	TP-109148	HAND KNOB
6	2	TP-110756	CASTER, SWIVEL
7	2	TP-110763	CASTER, RIGID

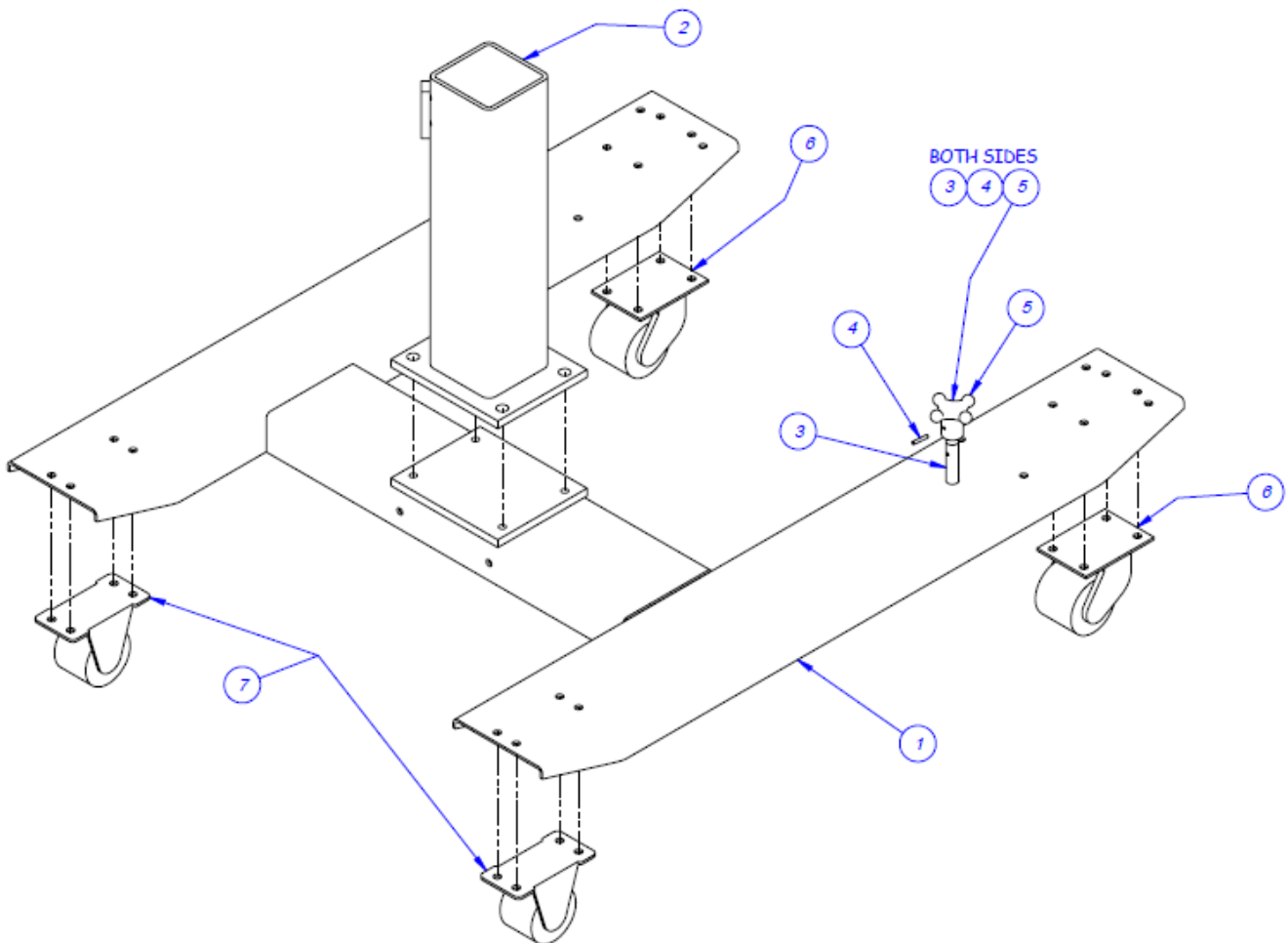

5.3 Upper Column Assembly

P/N: TA-T10210

ITEM NO.	QTY.	PART NO	DESCRIPTION
1	1	TP-T1MC00019-1	BASE CLAMP (L. H.)
2	1	TP-T1MC00019-2	BASE CLAMP (R. H.)
3	1	TP-T1MC00019-3	BRACKET, MOUNTING
4	1	TP-T1MA00087	CROSS PIPE
5	1	TP-401267	ELBOW, DOUBLE UNIVERSAL
6	1	TP-406260	FILTER/DRYER/REG. ASSEMBLY
7	1	TP-401222	HEX NIPPLE

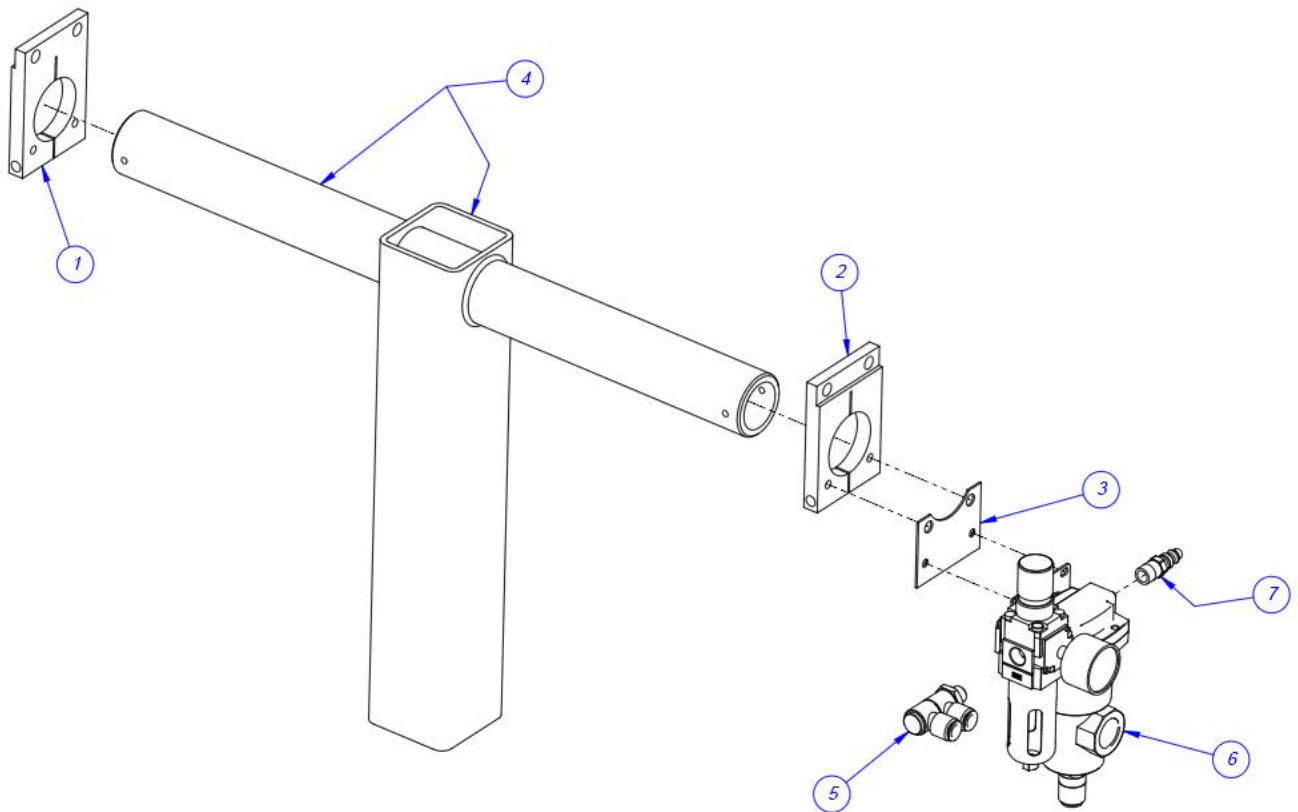

5.4 Covers and Guarding

P/N: TA-T1-S14NOPRINT

ITEM NO.	QTY	PART NO.	DESCRIPTION
1	1	TP-T1MD00004S14	ELECTRONICS COVER
2	1	TP-T1MD00005S14	RIGHT SIDE COVER
3	1	TP-T1MD000044	TOP COVER
4	2	TP-111241	SNAP BUTTON PLUG
5	1	TP-T1MO00226-4	LEXAN GUARD BRACKET (RIGHT)
6	1	TP-T1MD00116-2	LEXAN GUARD 5.25" PASS THROUGH
7	1	TP-T1MO00226-3	LEXAN GUARD BRACKET (LEFT)

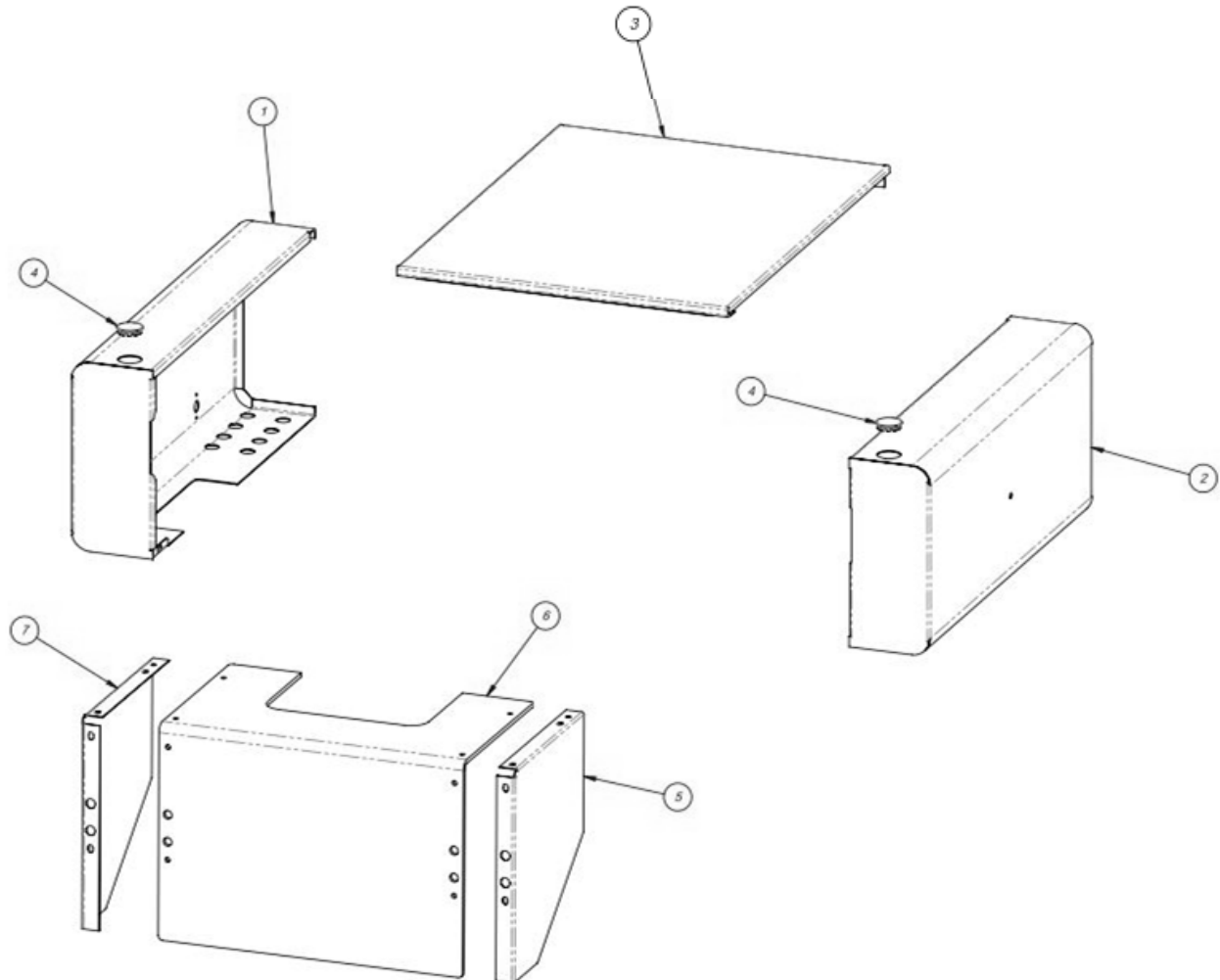

5.5 Flat Load Shelf Assembly

P/N: TA-T10018

ITEM NO.	QTY	PART NO.	DESCRIPTION
1	1	TP-T1MB00074-2	LOAD SHELF BRACKET (RIGHT)
2	1	TP-T1MB00074-1	LOAD SHELF BRACKET (LEFT)
3	1	TP-T1MB00075	9" FIXED LOAD SHELF
4	1	TP-T1MB00076	LOAD SHELF ROD

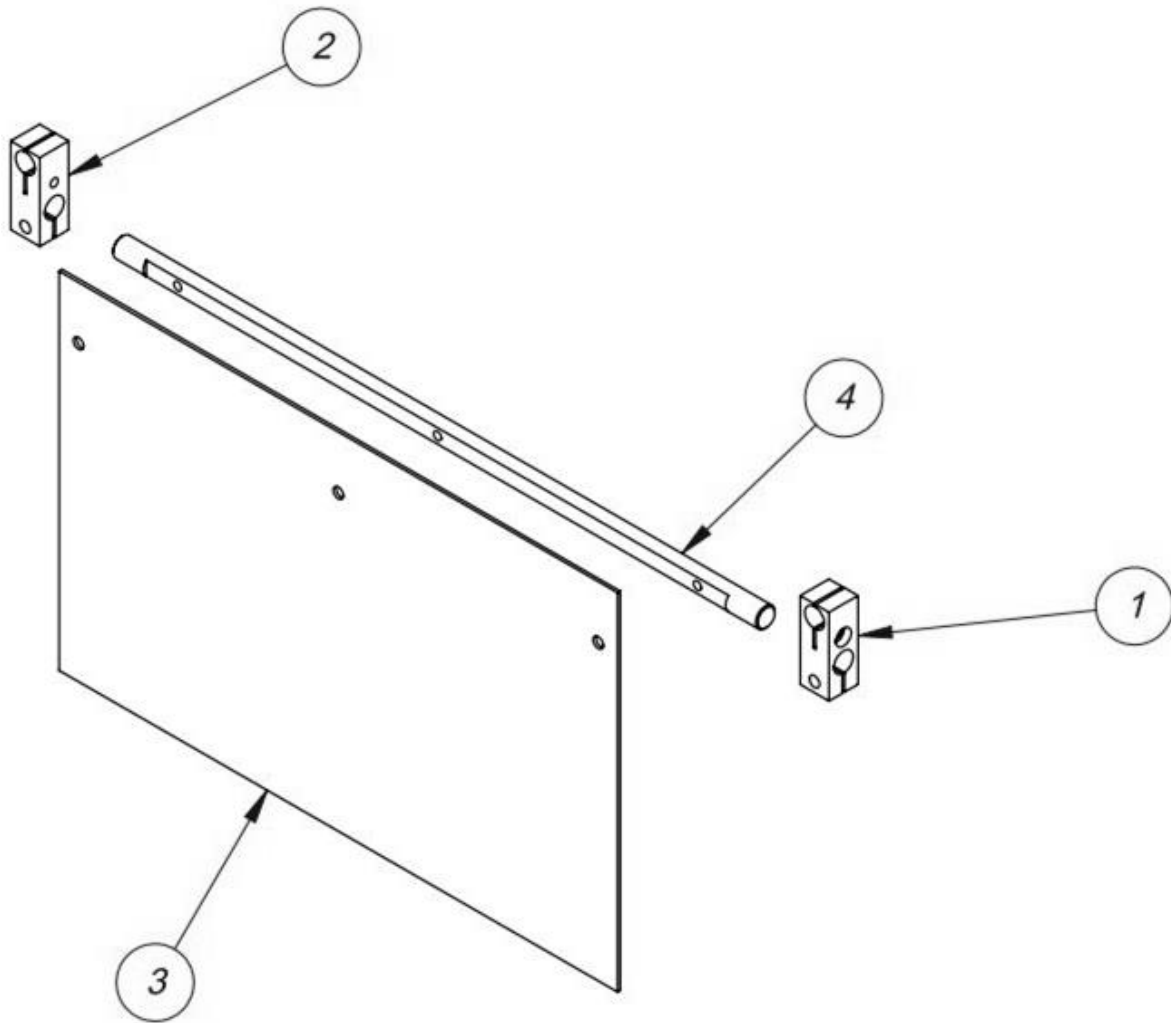

5.6 Dancer Assembly

P/N: TA-T10220

ITEM NO.	QTY.	PART NO	DESCRIPTION
1	1	TP-T1MA00069-1	DANCER SIDE PLATE
2	1	TP-C1MA00069-2	DANCER SIDE PLATE
3	1	TA-T10011	DANCER GUIDE SUB-ASSEMBLY
4	1	TP-T1MA00073	BAG ROLL SHAFT
5	2	TP-504132	CAM FOLLOWER
6	1	TP-T1MA00115	BELT TENSION STRAP & SPRING
7	2	TP-104148	SPACER
8	3	TP-101141	LOCKNUT, HEX #10-24
9	2	TP-T1MA00049	FILM TENSION HUB
10	2	TP-103307	SCREW, SHOULDER 1/4"D X 1-1/4"L X 10-24
11	2	TP-106106	SPRING PIN
12	2	TP-109212-1	"T" KNOB

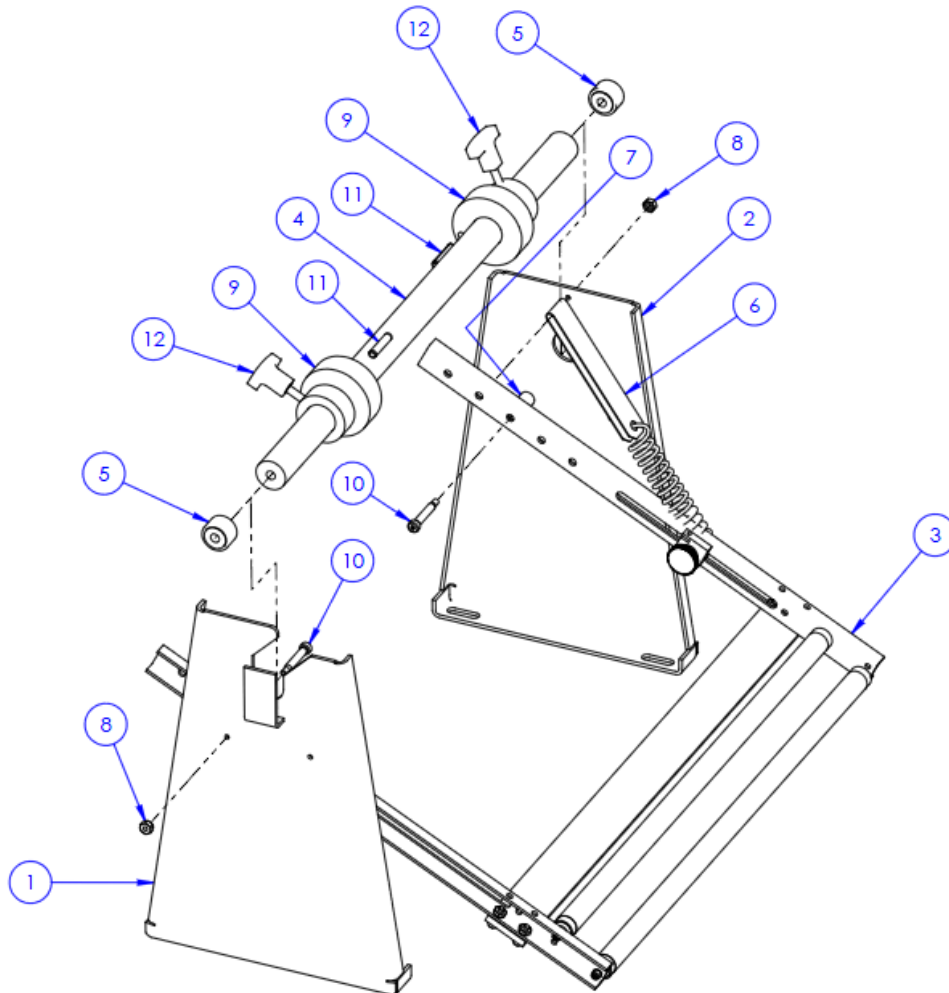

Dancer Guide Subassembly

P/N: TA-T10011

ITEM NO.	QTY.	PART NO	DESCRIPTION
1	1	TP-T1MA00081	DANCER TENSION BAR CROSS BRACE
2	1	TP-109212	KNOB
3	2	TP-T1MA00072	DANCER TENSION BAR
4	1	TP-T1MA00186	TENSION ADJUSTER
5	2	ASSEMBLY	GUIDE ROLLER ASSEMBLY

Guide Roller Assembly

ITEM NO.	QTY.	PART NO	DESCRIPTION
1	1	TP-T1MA00089	DANCER GUIDE ROLLER
2	1	TP-T1MA00090	DANCER GUIDE ROLLER SHAFT

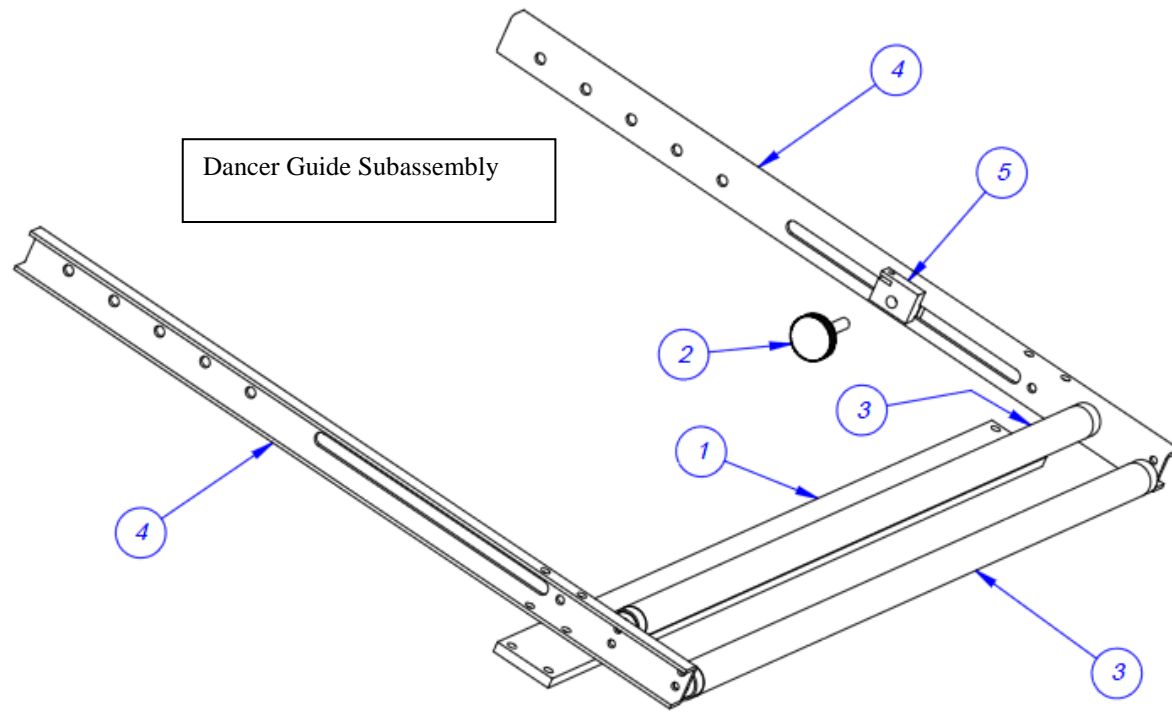

Dancer Guide Subassembly

Guide Roller Assembly

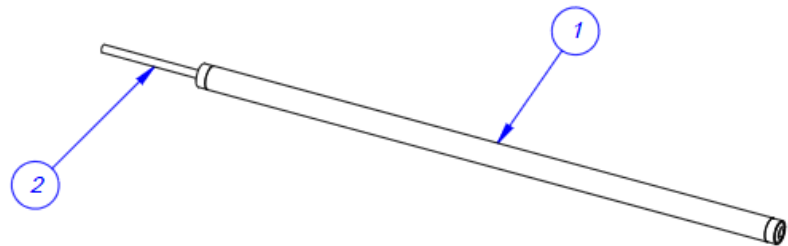

5.7 Touch Screen Assembly

P/N: TA-T10240

ITEM NO.	QTY.	PART No	DESCRIPTION
1	1	TA-T10240-IOP	SEVEN INCH TOUCH SCREEN
2	1	TP-T1MD00109	MOUNTING BAR
3	1	TP-111215	JOINING TEE
4	1	TP-T1MD00094	BASE TELESCOPE
5	1	TP-111104	COLLAR CLAMP
6	1	TP-T1MA00088	BASE CLAMP PIPE

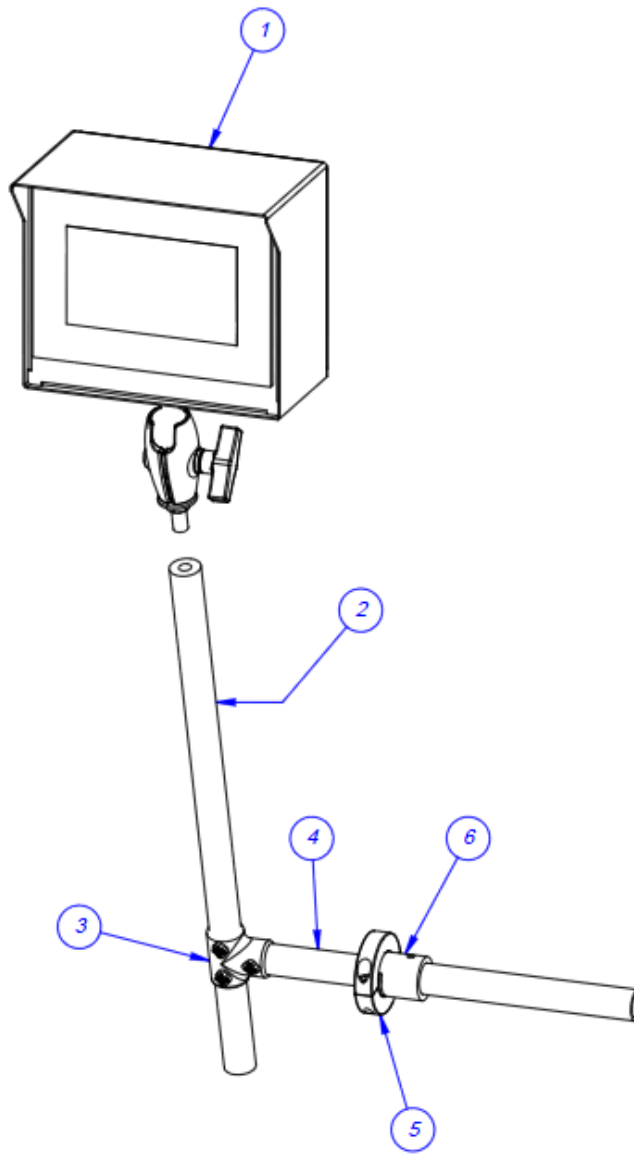

5.8 Seven Inch Touch Screen

TA-T10240IOP

ITEM NO.	QTY.	PART No	DESCRIPTION
1	1	TP-T1MD00040	TOUCH SCREEN HOUSING
2	1	TP-T1MD00040-1	BACK COVER
3	1	TP-111131	BALL GRIP POSITIONING ARM
4	1	TP-111125-2	SOCKET ARM
5	4	PART OF TP-220363	SCREEN STUD
6	4	PART OF TP-220363	SCREEN CLIP
7	1	TP-220363	TOUCH SCREEN
8	1	TP-IOPBOLT-L	MODIFIED BOLT
9	1	TP-102147	WASHER, 5/8 FLAT
10	1	TP-101125	NUT, 1/2-13 HEX JAM

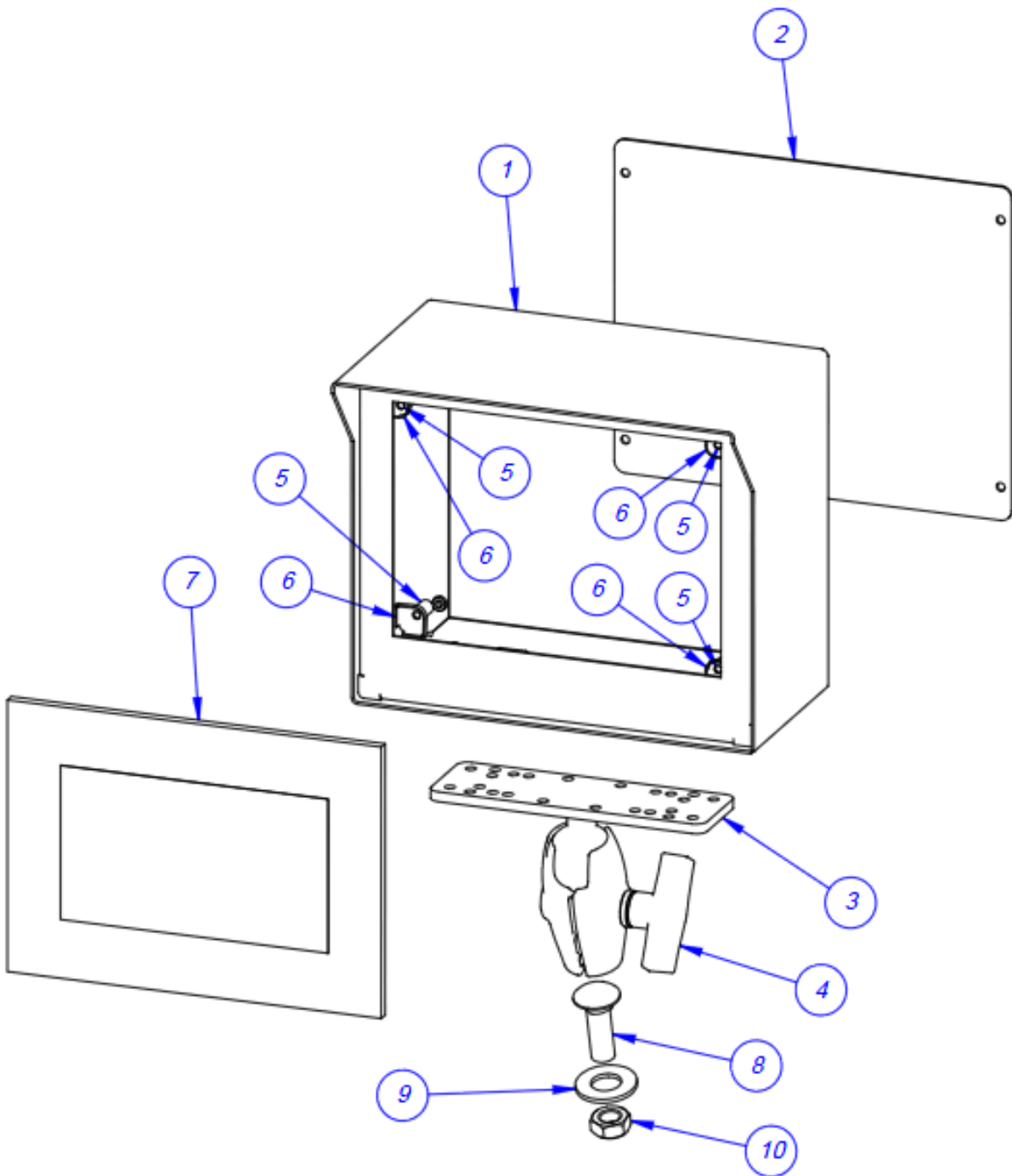

5.9 Main Frame Assembly

P/N: TA-T10250-S14

ITEM NO.	QTY.	PART NO	DESCRIPTION
1	2	TP-T1MC00001S14NB	SIDE FRAME
2	2	TP-T1MC00044	FACE PLATE BLOCK
3	1	TP-T1MC00042NB	FACE PLATE
4	1	TP-T1MC00079	CYLINDER PIVOT SHAFT
5	1	TP-T1MC00056	REAR CROSS SUPPORT SHAFT
6	4	TP-T100054	COVER SUPPORT CLAMP
7	2	TP-T1MC00099	REAR COVER SUPPORT
8	2	TP-T1MC00058	LATCH ADJUSTER BLOCK
9	2	TP-T1MC00059	LATCH LOCK BLOCK
10	1	TP-T1MC00163-2	GUIDE BLOCK - RH
11	1	TP-T1MC00163-1	GUIDE BLOCK - LH
12	2	TP-504113	BEARING
13	1	TP-T1MC00017	RUBBER ROLLER
14	2	TP-T1MC00082	COVER STAND-OFF
15	1	TP-T1MC00052	GUIDE ROLLER
16	2	TP-106106	SPRING PIN
17	2	TP-108099	COMPRESSION SPRING, .040 GAUGE, .359 OD.
18	2	TP-504101	BEARING
19	2	TP-111010	SPRING CLOSURE COLLAR
20	1	TP-501170	S14 STEPPER MOTOR
21	1	TP-T14M1027	MOTOR PULLEY
22	1	TP-T1MC00161	DRIVEN PULLEY
23	2	TP-111142	CLAMP, COLLAR
24	2	TP-215200	MAGNETIC SWITCH, T-1000 MACHINE OPEN SENSOR
25	1	TP-T1MD00010-S14	PNEUMATICS BACK PANEL
26	1	TA-T10002-S14	UPPER ROLLER ASSEMBLY
27	1	TP-502104	BELT 210XL037

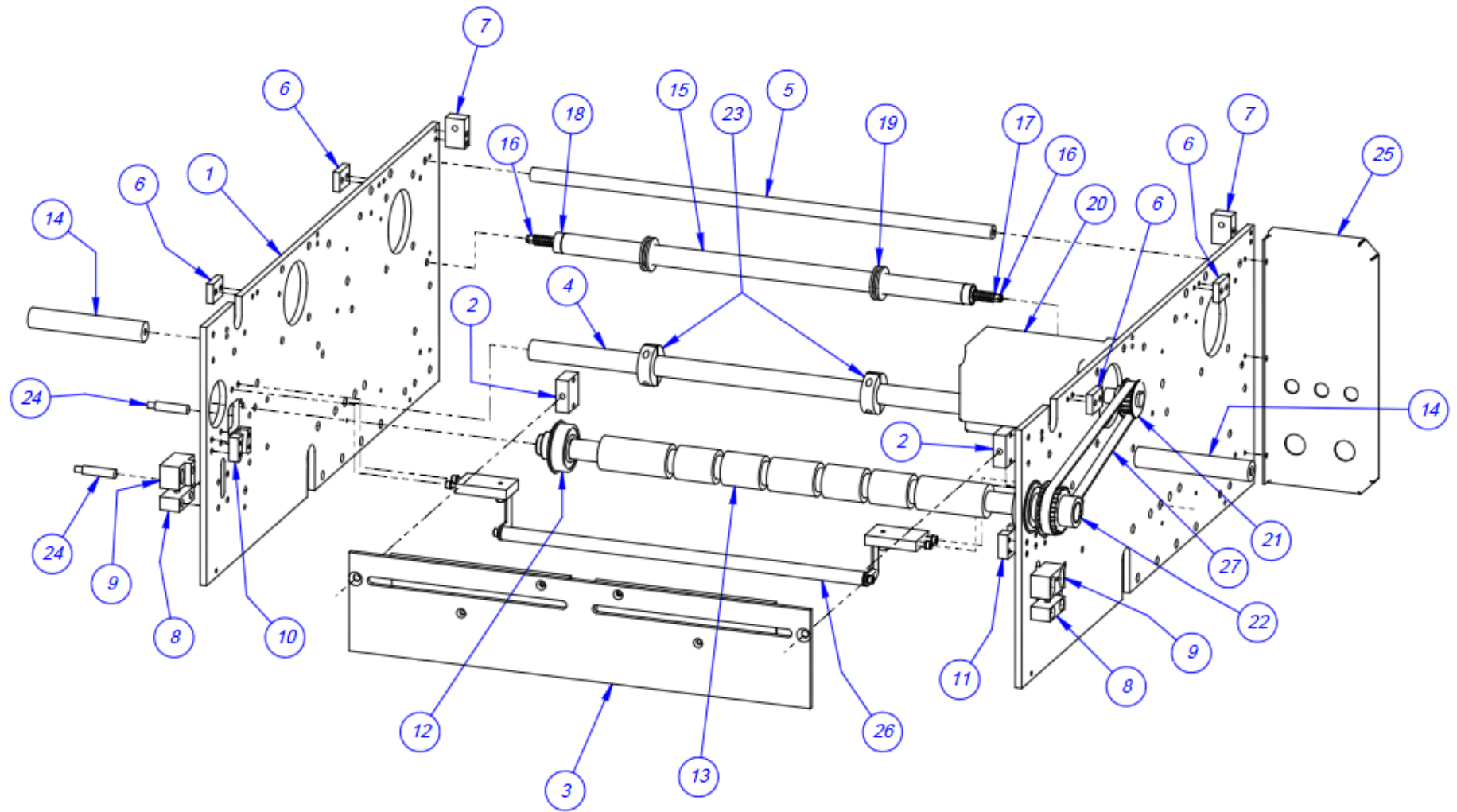

MAIN FRAME ASSEMBLY
P/N: TA-T10250-S14

5.10 Upper Roller Assembly

P/N: TA-T10002-S14

ITEM NO.	QTY	PART NO.	DESCRIPTION
1	1	TP-T1MC00119	FILM WEB ROLLER
2	1	TP-T1MC00120	FILM WEB ROLLER SHAFT
3	2	TP-107177	1/4" ID, 3/8" OD, 0.375" LONG BUSHING
4	2	TP-T1MC00018-S14	ROLLER MOUNT
5	1	TP-T1MC00118-1	FILM WEB ROLLER BRACKET LEFT
6	1	TP-T1MC00118-2	FILM WEB ROLLER BRACKET RIGHT

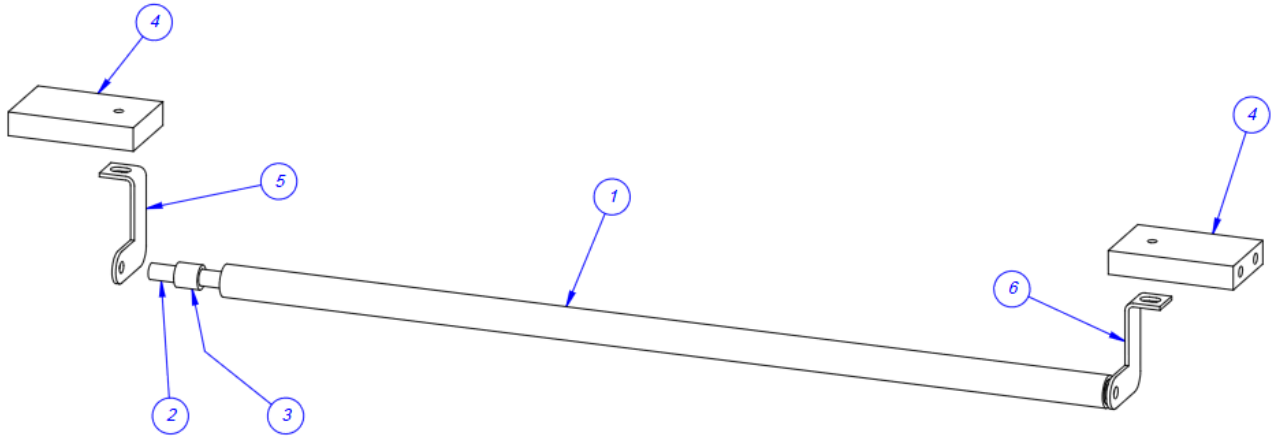

5.11 Air Knife Assembly

P/N: TA-T10001-S14

ITEM NO.	QTY	PART NO.	DESCRIPTION
1	1	TP-BP-1013-S14	MOUNTING BAR
2	1	TP-BP-1015-S14	AIR NOZZLE
3	1	TP-T1MC00020NB	FINGER PLATE
4	2	TP-T1MC00125S14	SENSOR MOUNTING BAR
5	1	TP-T1MC00083	HIGH VOLTAGE SENSOR INSULATOR
6	1	TA-T100124-1	HIGH VOLTAGE SENSOR
7	1	TP-405268	AIR KNIFE
8	1	TP-401277	ELBOW, ¼ TUBE
9	1	TP-401292	STRAIGHT, ¼ POLY x ¼ NPT
10	1	TP-401262	UNION, STRAIGHT ¼ TUBE
11	1	TP-406181	FILTER

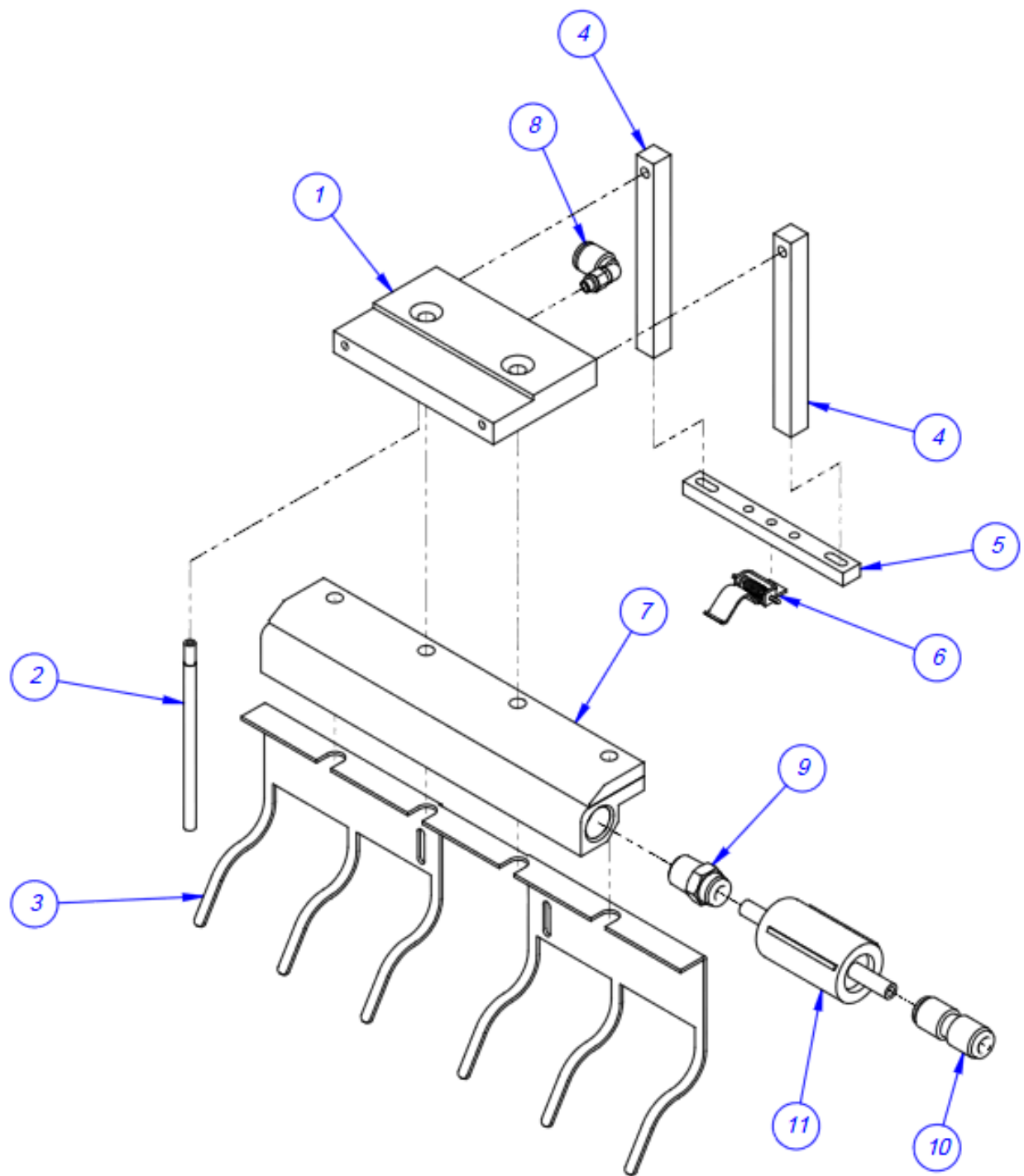

5.12 Sealer Frame Assembly: Drop Frame

P/N: TA-T10280-S14

ITEM NO.	QTY.	PART NO	DESCRIPTION
1	1	TP-T1MB00200	SEALER FRAME
2	1	TP-T1MD000276	NBO INTERNAL GUARD (4.25" PASS-THROUGH)
2	1	TP-T1MD00276NB-1	NBO INTERNAL GUARD (5.25" PASS-THROUGH)
2	1	TP-T1MD000276-2	NBO INTERNAL GUARD (6.25" PASS-THROUGH)
2	1	TP-T1MD000276-3	NBO INTERNAL GUARD (7.25" PASS-THROUGH)
3	1	TP-T1MD000275	BOTTOM INTERNAL GUARD (4.25" PASS-THROUGH)
3	1	TP-T1MD00275NB-1	BOTTOM INTERNAL GUARD (5.25" PASS-THROUGH)
3	1	TP-T1MD000275-2	BOTTOM INTERNAL GUARD (6.25" PASS-THROUGH)
3	1	TP-T1MD000275-3	BOTTOM INTERNAL GUARD (7.25" PASS-THROUGH)
4	1	TP-T1MD00277NB	SHORT INTERNAL GUARD
5	2	TP-402186	FLOW CONTROL, #10-32
6	2	TP-107127-1	BRONZE BUSHING
7	2	TP-401277	ELBOW, 1/4 TUBE
8	2	TP-403245	AIR CYLINDER
9	2	TP-T1MB00057	HEATER BAR YOKE
10	1	TA-T10009	PTFE GUIDE SUB-ASSEMBLY
11	1	TA-T10006	HEATER BAR SUB-ASSEMBLY
12	3	TP-211374	MAGNET, ROUND
13	1	TP-T1MB00164	PIVOT CLAMP
14	2	TP-101132	NUT, ACORN 5/16-18
15	2	TP-107228	BUSHING, NYLON FLANGE
16	2	TP-107227	BUSHING, THRUST NYLON
17	2	TP-401257	ELBOW, 1/4" TUBE x 1/8 NPT
18	4	TP-107160	PTFE COATED BUSHING
19	2	TP-T1MB00027	GRIPPER SPACER
20	1	TP-T1MB00005	FRONT GRIPPER PLATE
21	1	TP-T1MB00107	MAGNETIC SENSOR HOUSING
22	1	TP-102254	WASHER, FENDER
23	2	TP-T1MB00033	SEAL GUIDE ROD (4.25" Pass-Through)
23	2	TP-T1MB00033-1	SEAL GUIDE ROD (5.25" Pass-Through)
23	2	TP-T1MB00033-2	SEAL GUIDE ROD (6.25" Pass-Through)
23	2	TP-T1MB00033-3	SEAL GUIDE ROD (7.25" Pass-Through)
24	1	TA-T10005	PRESSURE BAR SUB ASSEMBLY
25	1	TP-T1MB00010	SEALER ROD TIE
26	1	TP-403244	CYLINDER (4.25" Pass-Through)
26	1	TP-403146	CYLINDER (5.25" Pass-Through)
26	1	TP-403242	CYLINDER (6.25" Pass-Through)
26	1	TP-403241	CYLINDER (7.25" Pass-Through)
27	1	TP-T1MB00016	SEAL CYLINDER MOUNTING BLOCK

28	2	TP-T1MB00022	GUARD ROD MOUNTING BLOCK
29	2	TP-T1MB00144	SHIELD MOUNTING ROD (4.25" Pass-Through)
29	2	TP-T1MB00144-1	SHIELD MOUNTING ROD (5.25" Pass-Through)
29	2	TP-T1MB00144-2	SHIELD MOUNTING ROD (6.25" Pass-Through)
29	2	TP-T1MB00144-3	SHIELD MOUNTING ROD (7.25" Pass-Through)
30	2	TP-104210	SPACER, 3/8LG,1/2 DIA.,.252 HOLE
31	1	TP-T1MO00129	DROP FRAME FACE PLATE
32	2	TP-T1MO00023	DROP FRAME SPACER
33	1	TA-T10017	BAG FINGER GROUNDING ASSY
34	1	TA-T10012NB	GROOVED ROLLER MTG. SUB-ASSY.
35	1	TP-403507 (OR 8)	SEAL FRAME STRUT
36	1	TP-T1MB00063	LATCH SHAFT
37	1	TA-T10019LH	LEFT HAND LATCH ASSEMBLY
38	1	TA-T10019	NO HANDLE LATCH ASSEMBLY
39	1	TA-T10020-S14	MANIFOLD ASSEMBLY
40	1	TP-T1ME00209	SEAL BAR COIL CABLE

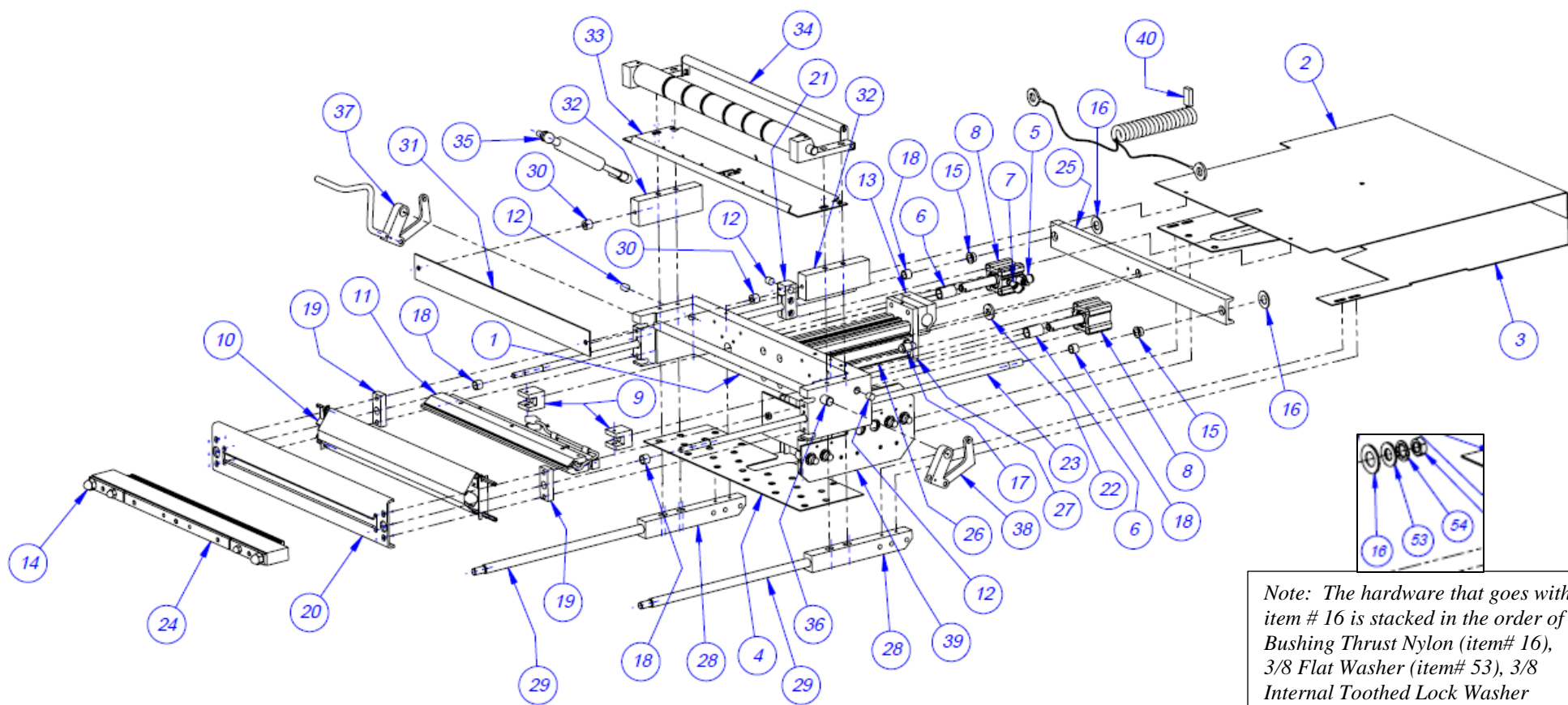

Note: The hardware that goes with item # 16 is stacked in the order of Bushing Thrust Nylon (item# 16), 3/8 Flat Washer (item# 53), 3/8 Internal Toothed Lock Washer (item# 54), then 3/8-16 Hex Jam Nut.

***Note:** If you purchased the T-1000-S14 with a Standard Frame instead of a Drop Frame, your part numbers for the Standard Sealer Frame Assembly are the same as those listed above with the exception of Item 30 TP-104210 Spacer, Item 31 TP-TIMO00129 Drop Frame Face Plate and Item 32 TP-TIMB00023 Drop Frame Spacer. Those three parts are not included in the Standard Frame Sealer Frame Assembly.

***Note:** Items 2, 3, 23, 26, and 29 will vary depending upon the Pass-Through size of the Bagger. Please note this when ordering parts from the Bill of Materials shown above. For example, a Bagger with a 6.25" Pass-Through will use NBO Internal Guard TP-T1MD000276-2, Bottom Internal Guard TP-T1MD000275-2, Seal Guide Rod TP-TIMB00033-2, Cylinder TP-403242, and Shield Mounting Rod TP-TIMB00144-2.

5.13 NBO Wide Seal Frame Assembly

P/N: TA-T10280-S18NB

ITEM NO.	QTY.	PART NO	DESCRIPTION
1	1	TP-T1-00200S18	SEALER FRAME
2	1	TP-T1MB00010-W18	SEALER ROD TIE BAR
3	1	TP-T1MB00016-S18	SEAL CYLINDER MOUNTING BLOCK
4	1	TP-T1MB00005-W18	FRONT GRIPPER PLATE
5	2	TP-T1MB00033-W18-1	SEAL GUIDE ROD (5.25" Pass Through)
5	2	TP-T1MB00033-W18-2	SEAL GUIDE ROD (6.25" Pass Through)
5	2	TP-T1MB00033-W18-3	SEAL GUIDE ROD (7.25" Pass Through)
6	2	TP-T1MB00057	HEATER BAR YOKE
7	2	TP-T1MB00144-1	SHIELD MOUNTING ROD (5.25" PASS-THROUGH)
7	2	TP-T1MB00144-2	SHIELD MOUNTING ROD (6.25" PASS-THROUGH)
7	2	TP-T1MB00144-3	SHIELD MOUNTING ROD (7.25" PASS-THROUGH)
8	2	TP-T1MB00022	GUARD ROD MOUNTING BLOCK
9	1	TP-T1MB00164	PIVOT CLAMP
10	1	TA-T10005-W18	PRESSURE BAR SUB ASSEMBLY
11	1	TA-T10006-W18	HEATER BAR SUB-ASSEMBLY
12	1	TA-T10019	NO HANDLE LATCH ASSEMBLY
13	1	TA-T10019LH	LEFT HAND LATCH ASSEMBLY
14	1	TA-T10012-W18	GROOVED ROLLER MOUNT ASSY
15	1	TP-102109	HEAT TREATED WASHER
16	1	TA-T10009	PTFE GUIDE SUB-ASSEMBLY
17	2	TP-T1MO00023-W18	DROP FRAME SPACER
18	1	TP-T1MB00063-W18	LATCH SHAFT
19	1	TA-T10017	BAG FINGER GROUNDING ASSY
20	1	TP-T1MB00107-S18	MAGNETIC SENSOR BLOCK
21	1	TP-403146	MAIN CYLINDER (5.25" PASS-THROUGH)
21	1	TP-403242	MAIN CYLINDER (6.25" PASS-THROUGH)
21	1	TP-403241	MAIN CYLINDER (7.25" PASS-THROUGH)
22	1	TA-T10020-S14	MANIFOLD ASSEMBLY
23	2	TP-403245	AIR CYLINDER
24	1	TP-T1MD00277NB-S18	SHORT INTERNAL GUARD
25	2	TP-T1MD00276NB-S18-4	GUARD BRACKET
26	1	TP-T1MD00276NB-S18-2	NBO INTERNAL GUARD
27	2	TP-401257	ELBOW, 1/4" TUBE x 1/8 NPT
28	2	TP-401277	ELBOW 1/4" TUBE x #10-32

29	2	TP-402186	FLOW CONTROL, #10-32
30	2	TP-211374	MAGNET, ROUND
31	2	TP-T1MB00027-1	GRIPPER SPACER (W)
32	4	TP-104210	SPACER, 3/8LG,1/2 DIA.,.252 HOLE
33	1	TP-T1MD00275NB-S18-2	BOTTOM INTERNAL GUARD
34	2	TP-107127-1	BRONZE BUSHING
35	1	TP-T1MBO0129-W18	DROP FRAME FACE PLATE (WIDE)
36	2	TP-107228	BUSHING, NYLON FLANGE
37	4	TP-107160-1	PTFE COATED BUSHING
38	2	TP-104124	SPACER
39	1	TP-T1ME00209	SEAL BAR COIL CABLE
40	1	TP-403508	GAS SPRING
41	2	TP-107227	BUSHING, THRUST NYLON

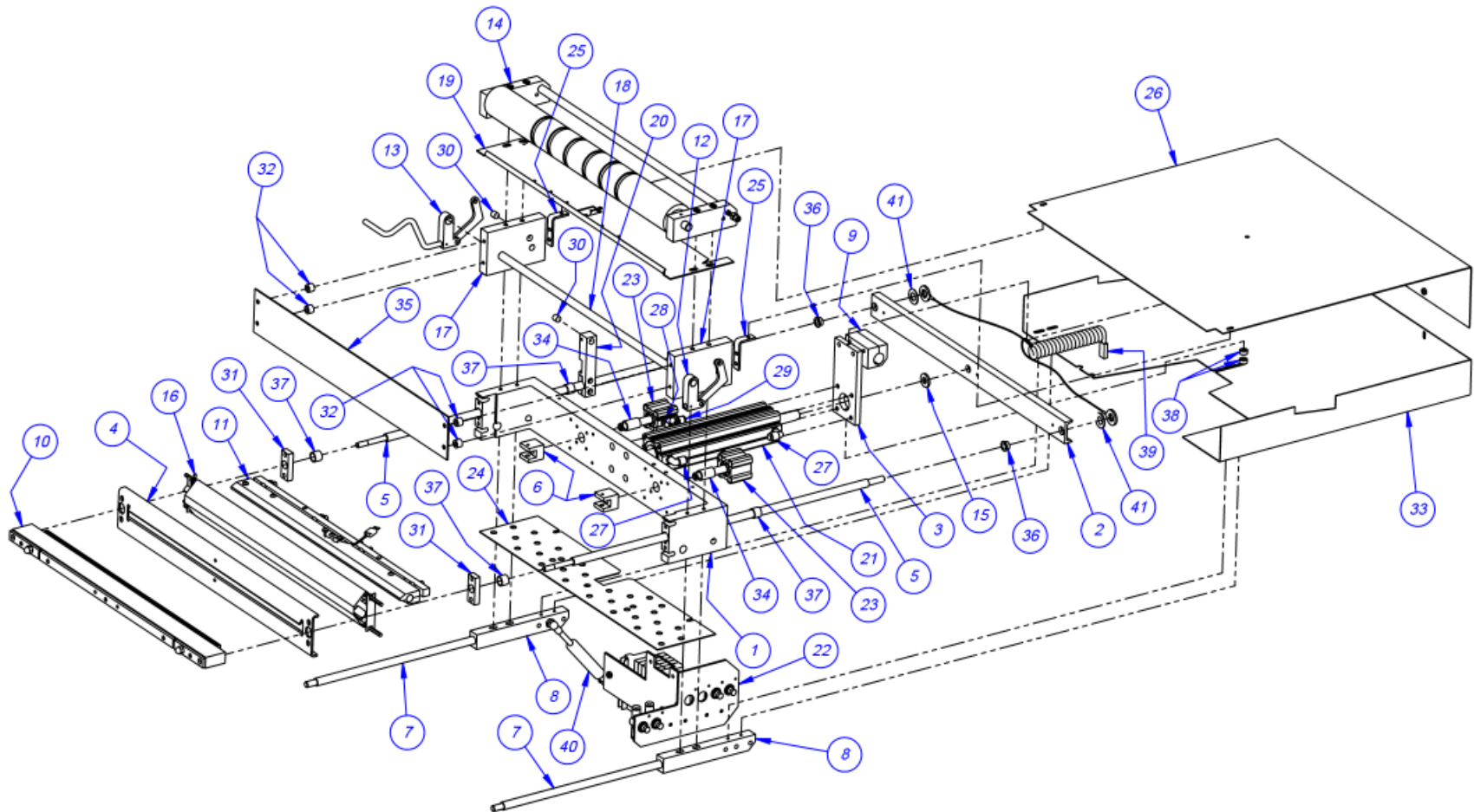

****Note: Items 5, 7, and 21 will vary depending upon the Pass-Through size of the Bagger. Please note this when ordering parts from the Bill of Materials shown above. For example, a Bagger with a 6.25" Pass-Through will use Seal Guide Rod TP-T1MB00033-W18-2, Shield Mounting Rod TP-T1MB00144-2, and Main Cylinder TP-403242.***

A. Pressure Bar Subassembly

P/N: TA-T10005

ITEM NO.	QTY.	PART NO	DESCRIPTION
1	1	TP-T1MB00029	ANTI-JAM PRESSURE HOUSING
2	1	TP-T1MB00030	ANTI-JAM CONTACT STRIP
3	1	TP-T1MB00031	ANTI-JAM PRESSURE PAD
4	2	TP-T1MB00068	ANTI-JAM CONTACT STRIP
5	1	TP-T1MB00111	RUBBER STRIP HOLDER
6	1	TP-306002	RUBBER SEAL
7	4	TP-300001	RUBBER BUMPER
8	2	TP-106093	1/4-20 x 2" STUD
9	4	TP-108155	COMPRESSION SPRING
10	2	TP-101130	NUT, 1/4-20 ACORN HEX

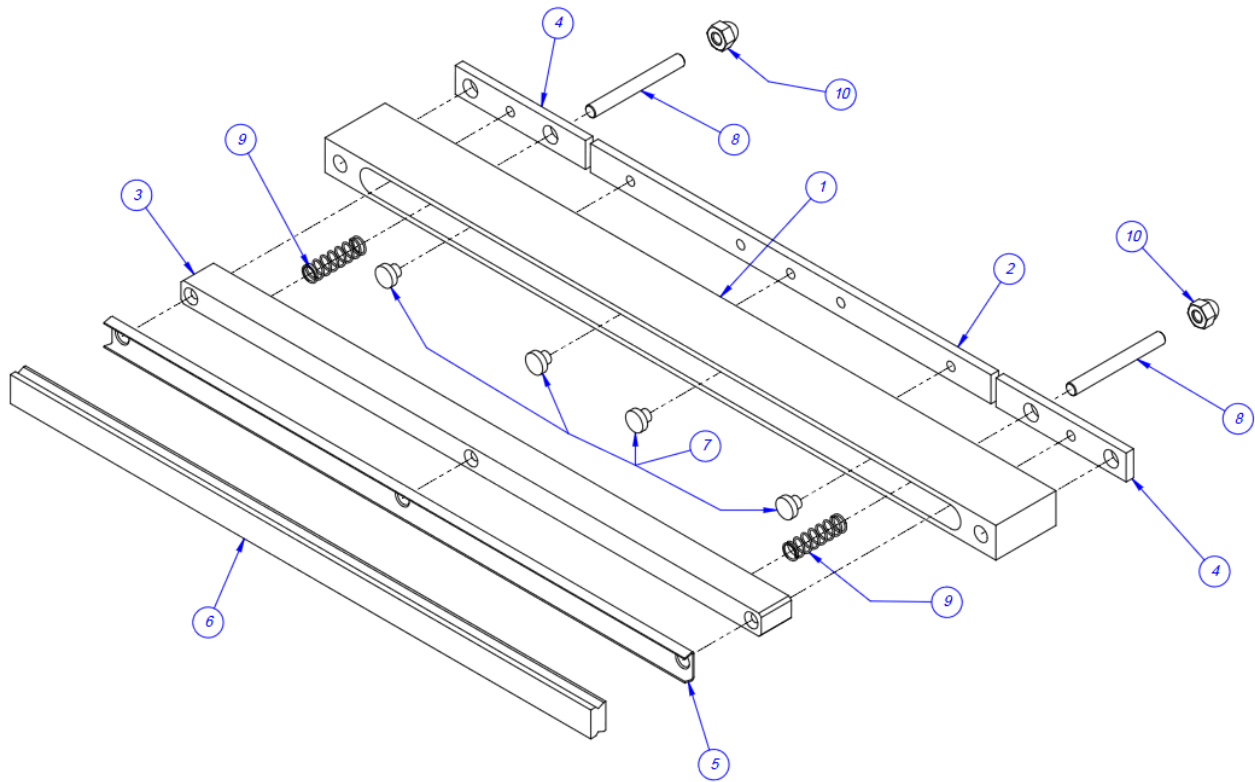

B. Heater Bar Subassembly

P/N: TA-T10006

ITEM NO.	QTY	PART NO.	DESCRIPTION
1	1	TP-T1MB00008	HEATER BAR MOUNTING PLATE
2	1	TP-221416	THERMOCOUPLE WIRE
3	2	TP-109096	HEATER CARTRIDGE WIRE LEAD CLAMP
4	1	TP-T1MB00145	WIRE TIE-DOWN
5	1	TP-T1MB00006	HEATER BAR CLAMP
6	1	TP-T1MB00009-1	1/8" SEAL BAR
7	1	TP-217116	CARTRIDGE, HEATER
8	4	TP-104124	SPACER

**Note: Depending on your order, Item 6 could also be TP-T1MB00009 Heater Seal Bar, TP-T1MB00009-2 1/4" Seal Bar, TP-T1MB00009-3 Three Point Seal or TP-T1MB00009-5 3/8" Seal Bar.*

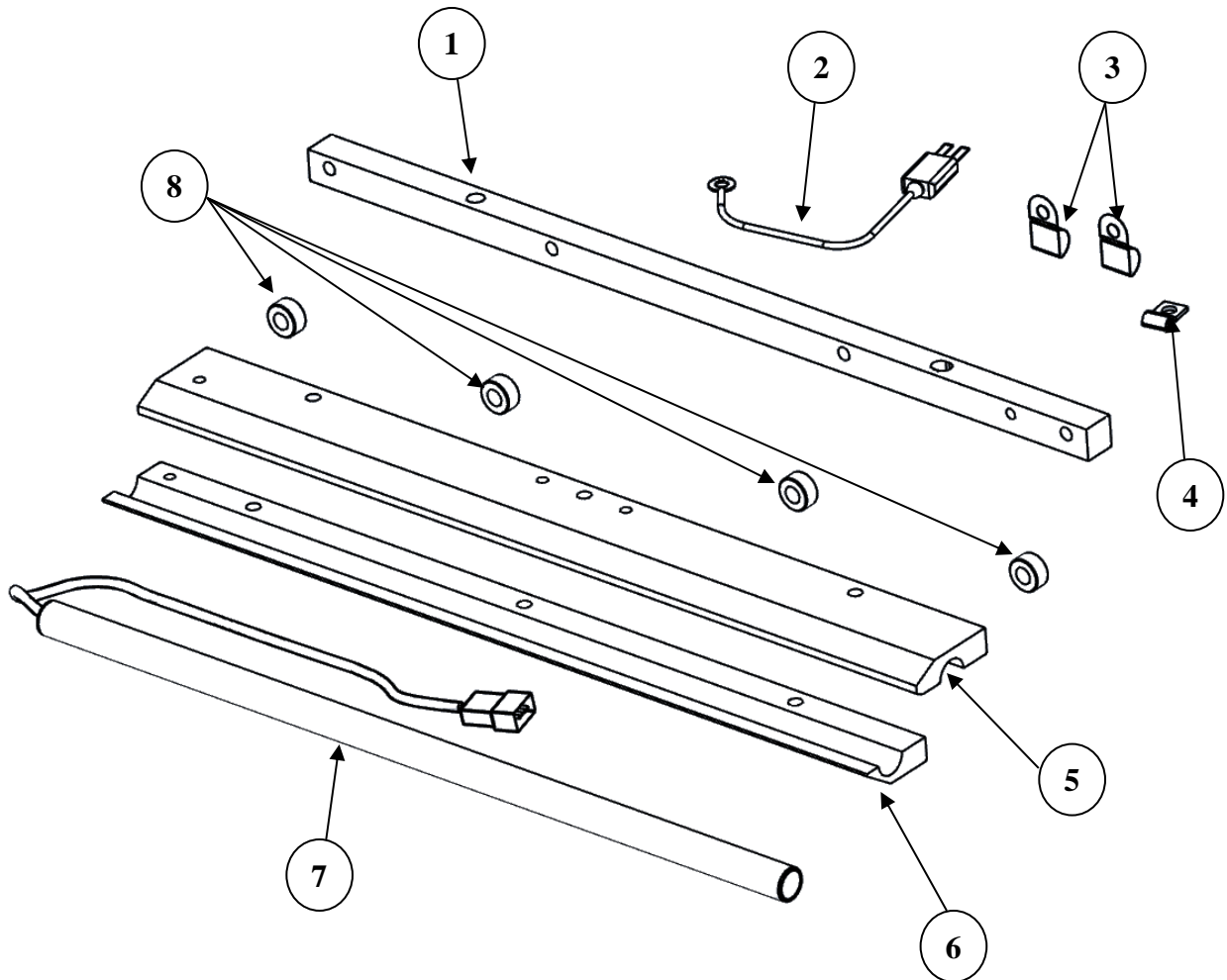

C. PTFE Guide Subassembly

P/N: TA-T10009

ITEM NO.	QTY	PART NO.	DESCRIPTION
1	1	TP-T1MB00034	PTFE FINGER
2	2	TP-T1MB00040	PTFE ROD
3	2	TP-108089	EXTENSION SPRING
4	1	TP-300500	PTFE SHEET

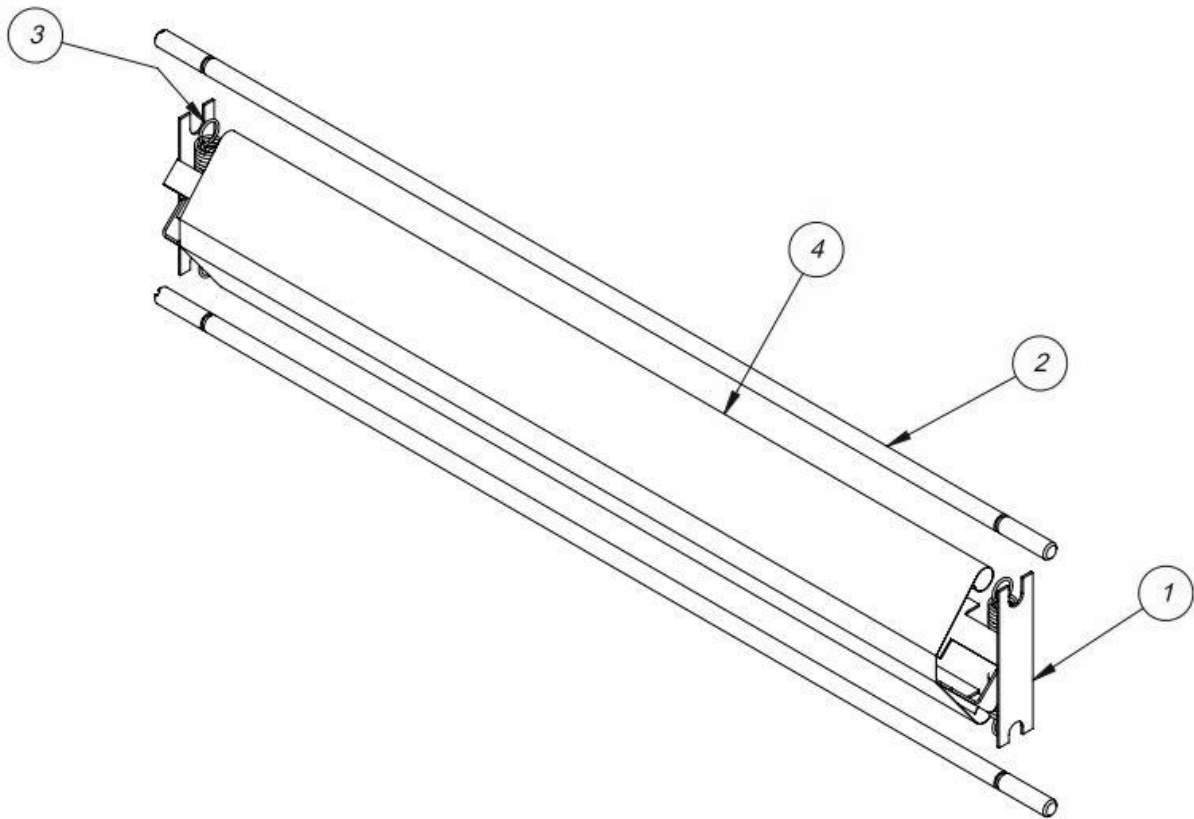

D. Grooved Roller Mounting Subassembly

P/N: TA-T10012

ITEM NO.	QTY	PART NO.	DESCRIPTION
1	1	TP-T1MB00013	ALUMINUM ROLLER SHAFT
2	2	TP-T1MB00004NB	ROLLER MOUNTING BLOCK
3	1	TP-T1MB00012	ROLLER
4	2	TP-107227	BUSHING, THRUST NYLON
5	2	TP-504107	BEARING, 0.500 BORE, 1.125 OD, 9/32 WIDE
6	1	TP-T1MB00155	FILM WEB TENSION ROLL
7	1	TP-T1MB00156	FILM WEB TENSION SHAFT
8	2	TP-T1MC00121	REAR ROLLER CLIP
9	2	TP-107163	1/4" ID x 3/8" x 0.250" BUSHING

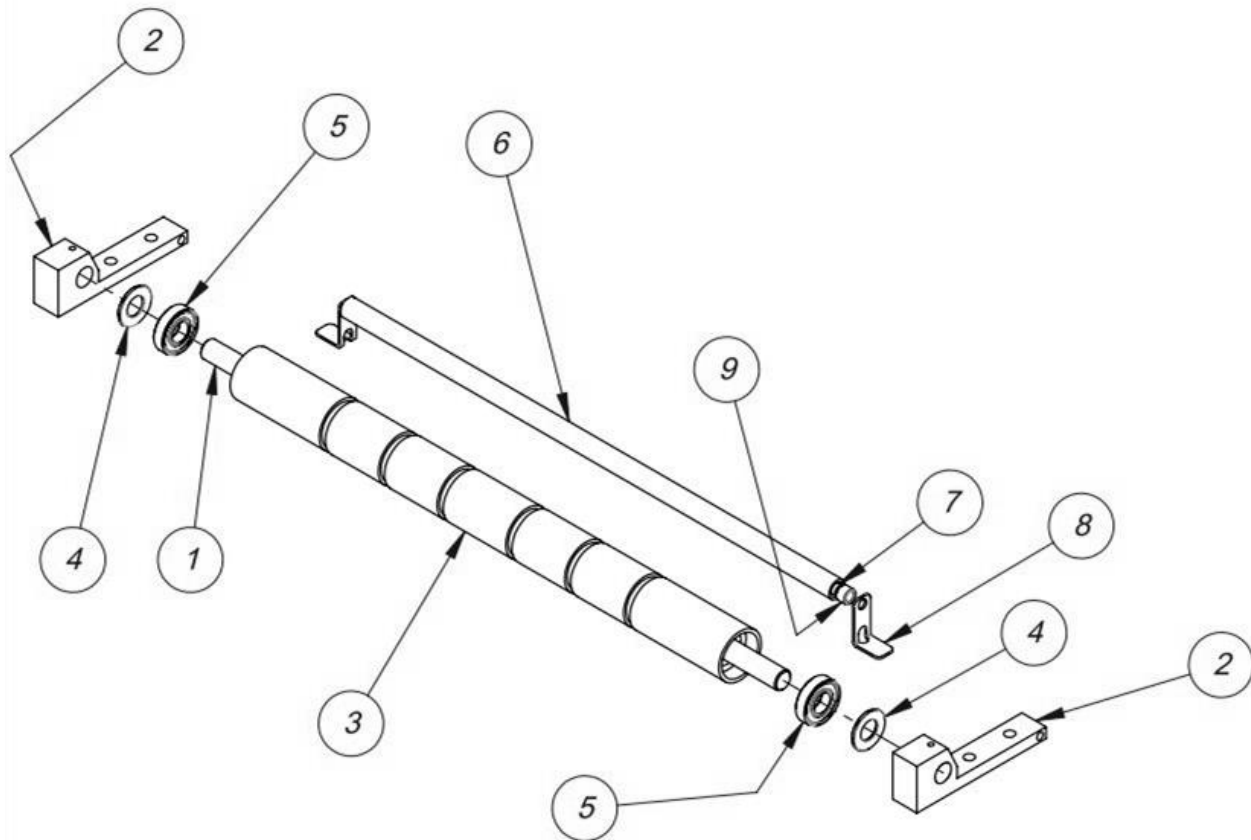

E. Bag Finger Grounding Subassembly

P/N: TA-T10017

ITEM NO.	QTY	PART NO.	DESCRIPTION
1	1	TA-T100124-3	GROUNDING SENSOR
2	1	TP-T1MB00028	GROOVED METAL ROLLER FINGER
3	1	TP-T1ME00325	GROUNDING SENSOR WIRE ASSEMBLY

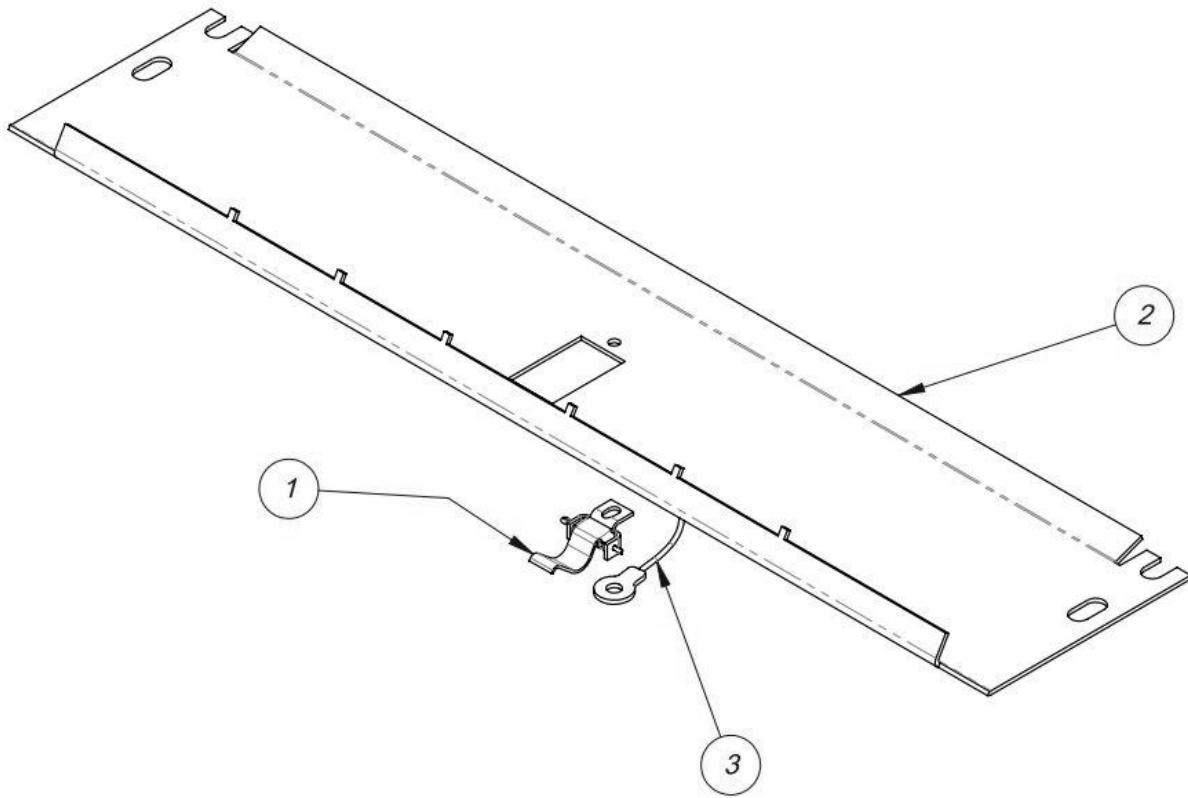

F. Latch Subassembly

P/N: TA-T10019

ITEM NO.	QTY	PART NO.	DESCRIPTION
1	1	TP-T1MB00060	LATCH LOCK
2	1	TP-T1MB00061	LATCH CAM
3	1	TP-106135	DOWEL PIN

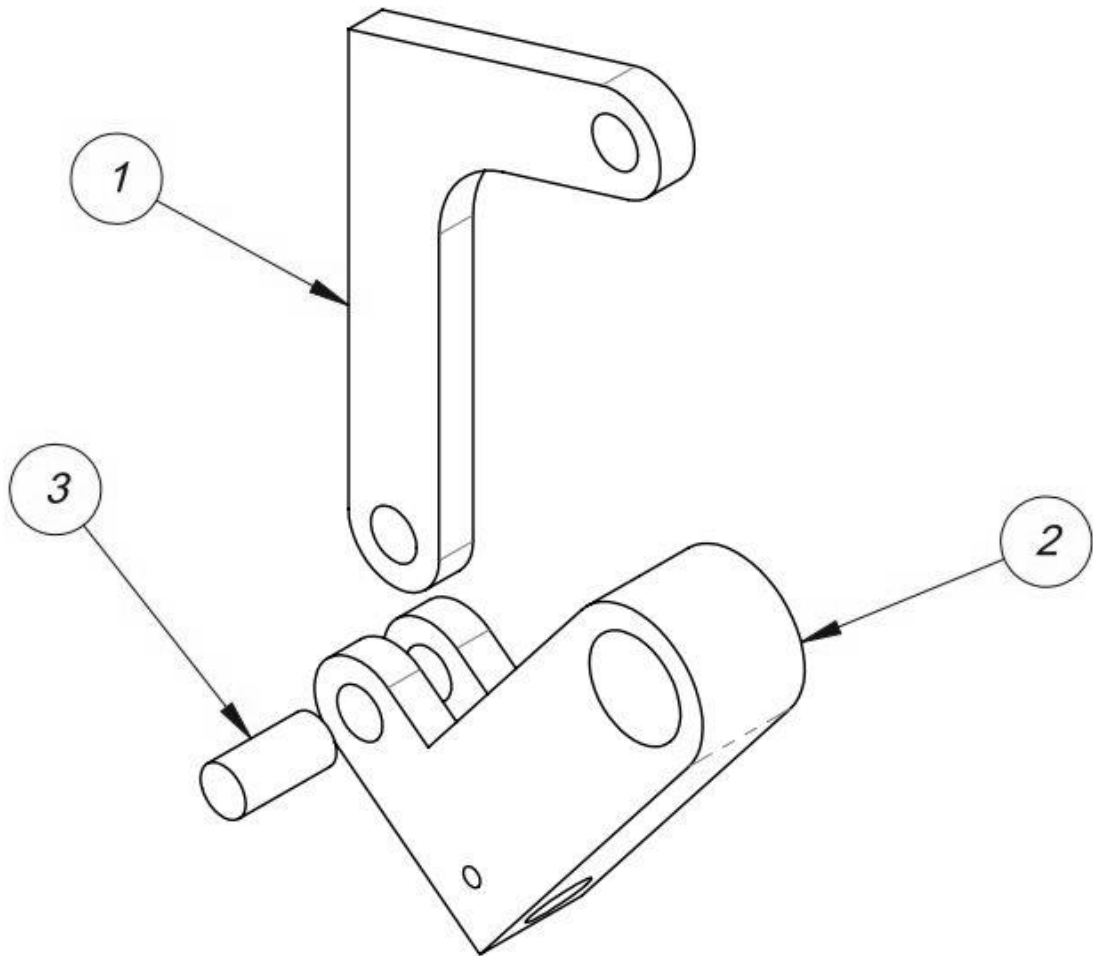

G. Manifold Assembly

P/N: TA-T1-10020-S14

ITEM NO.	QTY	PART NO.	DESCRIPTION
1	1	TP-T1MC00015S14	MANIFOLD BRACKET
2	2	TP-402104	IN-LINE FLOW CONTROL, AS2051F-07
3	1	TA-T1-10025-S14	PNEUMATIC VALVE ASSEMBLY

Note: Valves with one button (Single Valves) are part # TP-402266. Valves with two buttons (Dual Valves) are part # TP-402267.

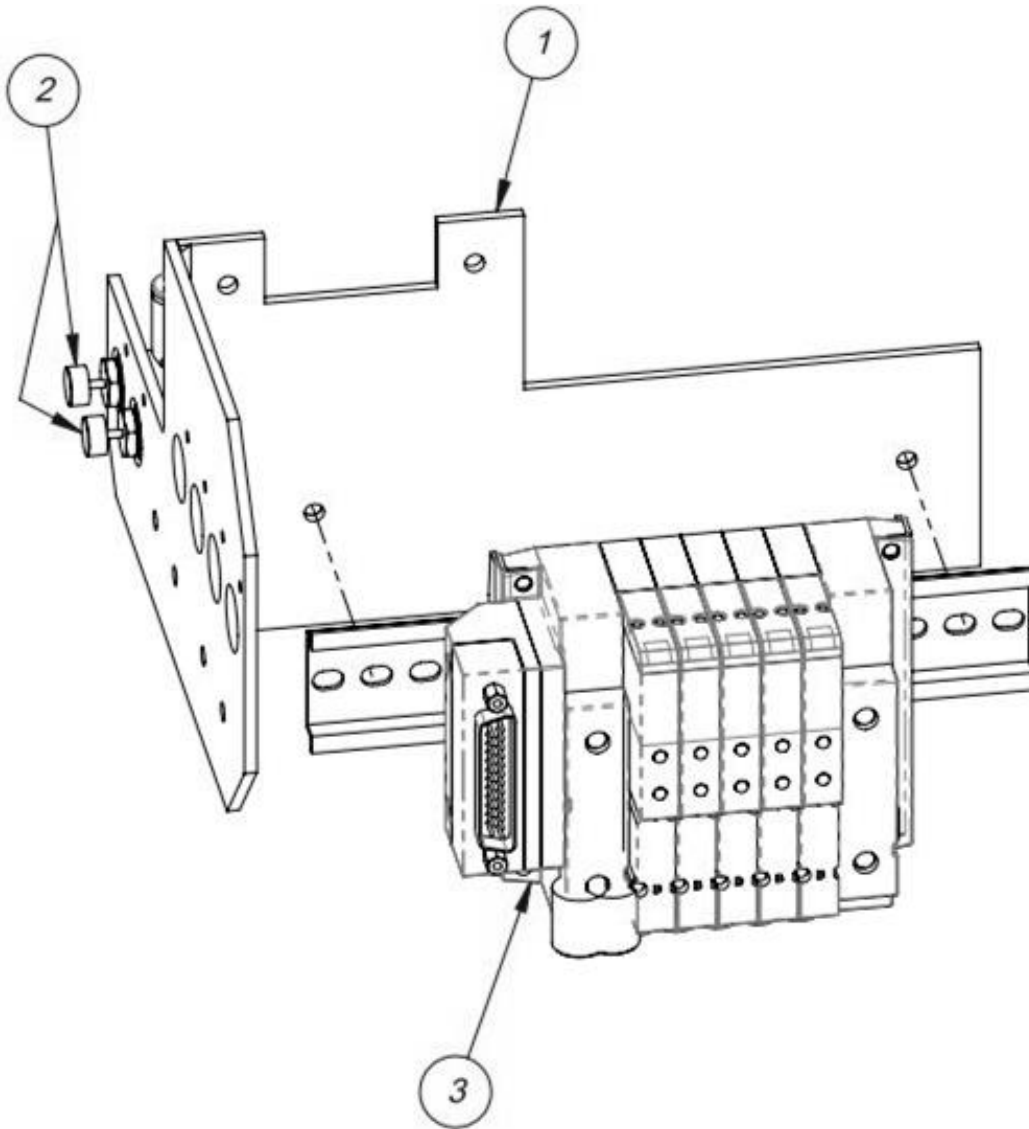

5.14 Electrical Panel

P/N: TA-T10270-S14

ITEM NO.	QTY.	PART NO	DESCRIPTION
1	1	TP-T1MC00006-S14	ELECTRONICS MOUNTING PANEL
2	1	TP-205108	EMI FILTER, CORCOM
3	1	TP-207216, TP-207344	FUSE HOLDER & FUSE
4	1	TP-212167	6-PIN CIRCULAR FEMALE
5	2	TP-212247	9-PIN D-SUB FEMALE
6	1	TP-212410	AC OUTLET
7	1	TP-213361	24VDC, 3AMP POWER SUPPLY
8	1	TP-215000A	COVER
9	1	TP-215000	SOLID STATE RELAY
10	1	TP-211386	HIGH VOLTAGE TRANSFORMER
11	1	TP-T1ME00301	HIGH VOLTAGE BOARD
12	1	TP-215384	POWER SWITCH
13	2	TP-214279	STAND-OFF 1"
14	18	TP- 208142	LARGE TERMINAL BLOCK
15	1	TP-218021	DIN RAIL
16	4	TP-214268	STAND-OFF .38"
17	1	TP-215005	SWITCH
18	1	TP-T1MC00021	TRANS MOUNTING PLATE
19	1	TP-212160	5-POS MINI DIM
20	1	TP-T1MC00016S14	ELECTRONICS MOUNTING BRACKET
21	1	TP-212248	25-PIN D-SUB FEMALE
22	1	TP-218020	DIN RAIL
23	1	TP-220511, TP-214111, TP-220513	PLC, BATTERY & COMM 2 CAS
24	1	TP-220514	PLC, FPO-E32T-A Expansion I/O
25	1	TP-T1MO00228	T-1000 EURO DISCONNECT SWITCH
26	2	TP-T1MO00229	STANDOFF
27	1	TP-212166	6-PIN MALE
28	1	TP-212338	10-PIN FEMALE
29	1	TP-220508	PLC ANALOG MODULE
30	1	TP-TP-212242	3-PIN SOCKET W/ANGLE BRACKET
31	1	TP-215004	SWITCH KNOB
32	1	TP-215115 & 215116	AUX RELAY & SOCKET
33	1	TP-112240	POWER CORD STRAIN RELIEF
34	1	TP-215400	ETHERNET COUPLER
35	1	TP-T1MC00002S14	ANGLE MOUNT 5-PHASE DRIVER
36	1	TP-501169-1	5-PHASE DRIVER

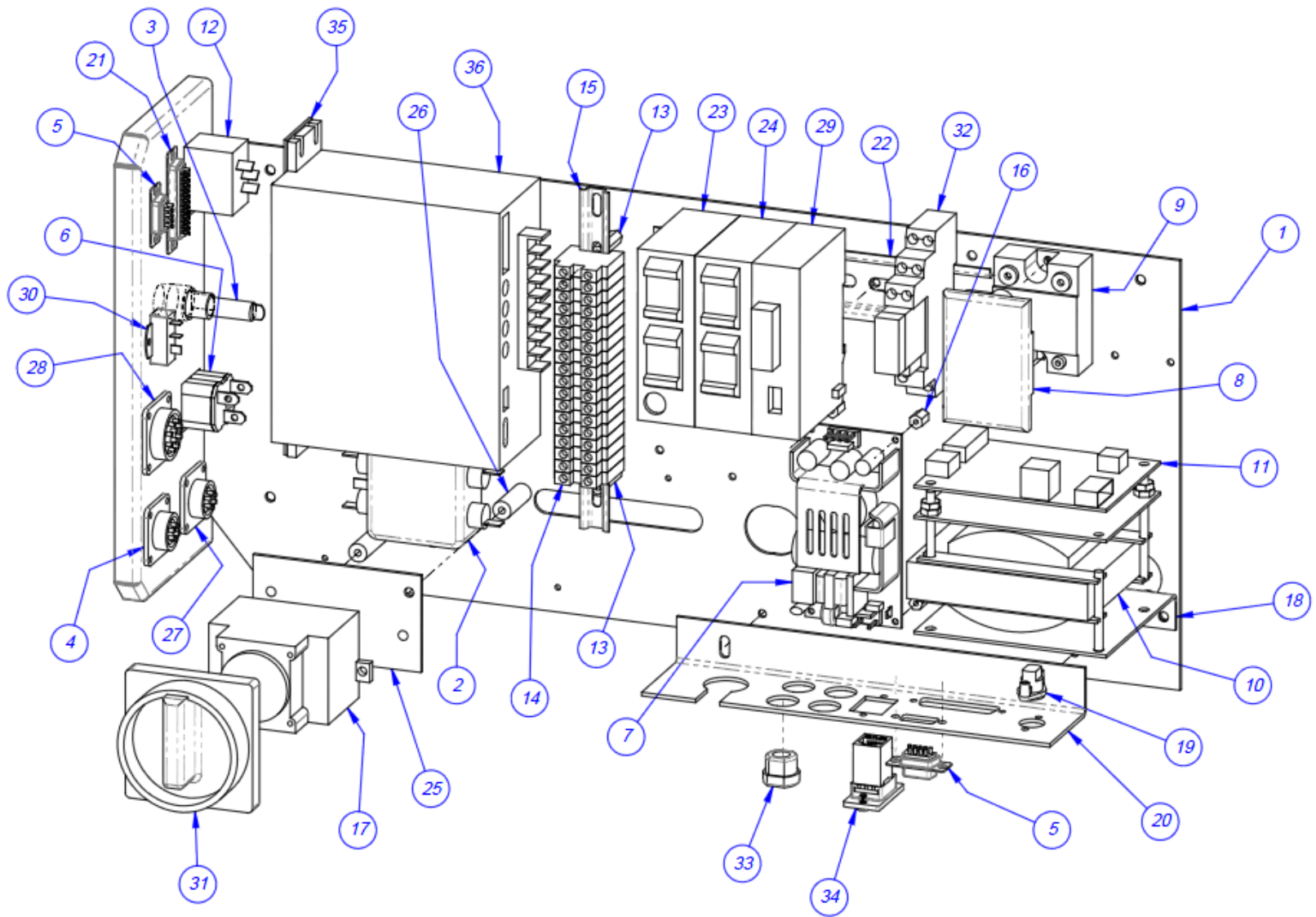

ELECTRICAL PANEL
P/N: TA-T10270-S14

5.15 Bag Blow Off (Optional)

TO-T1-BB10

ITEM NO.	QTY.	PART NO	DESCRIPTION
1	1	TP-TS10-106	TRIM SEAL BLOW-OFF
2	1	TP-404002	NOZZLE, SAFETY BLOW GUN
3	1	TP-401258	MALE CONNECTOR

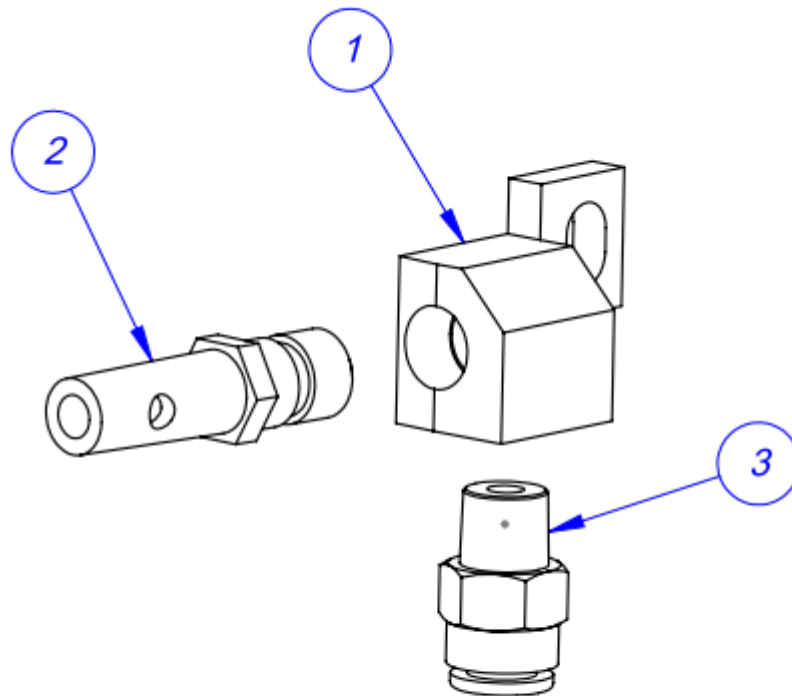

5.16 Bag Deflator (Optional)

TO-T1-BF10-2

ITEM NO.	QTY.	PART NO	DESCRIPTION
1	1	TP-BF10-160	BACK PLATE
2	1	TP-BF10-157	PLATE CLAMP
3	1	HP-35027A1	SPONGE REPLACEMENT

