

# LM3612

## PRINT & APPLY

# OPERATIONS MANUAL

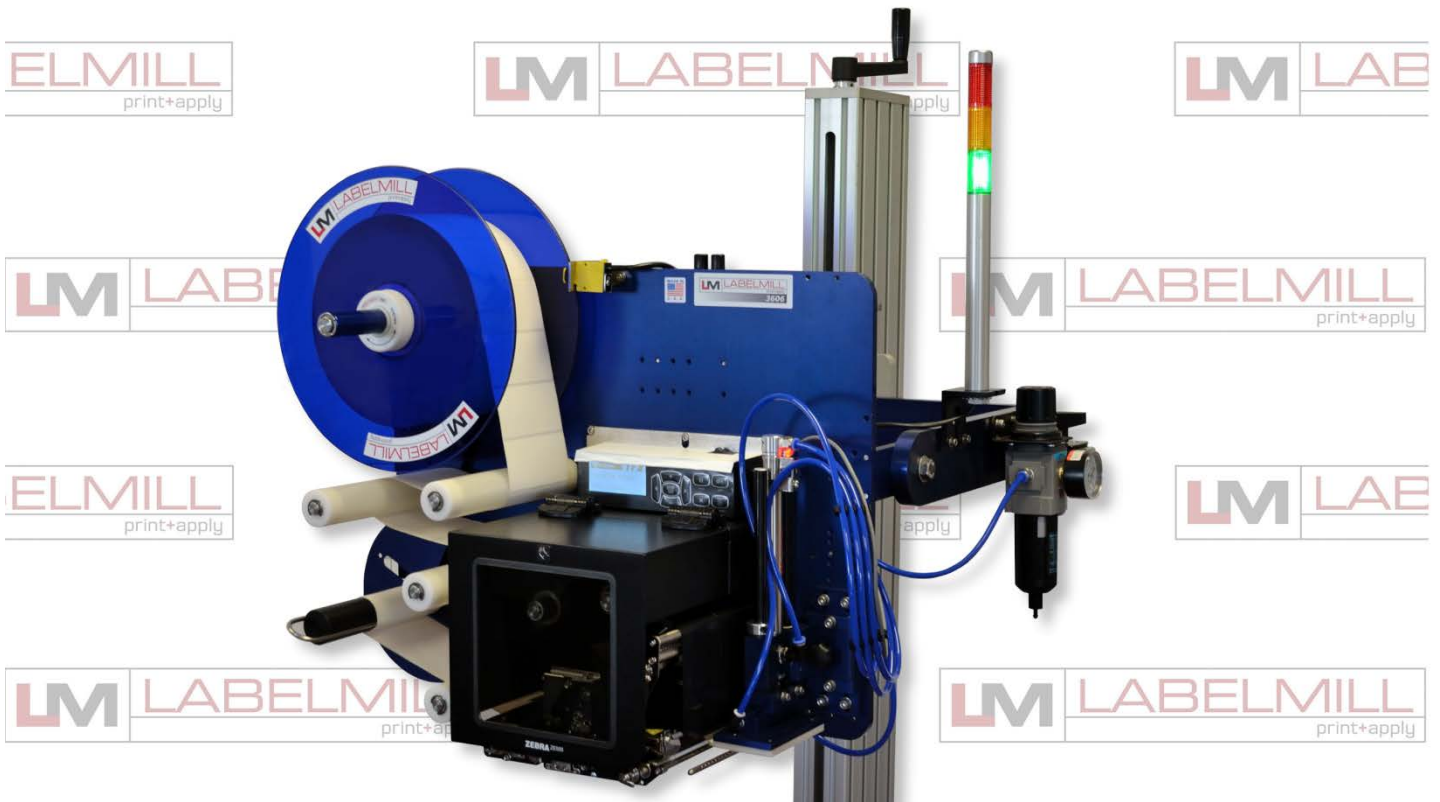

Manufactured in USA by:

**LabelMill, Inc.**

2416 Jackson St.

Savanna, IL 61074

(800) 273-4707

[info@labelmill.com](mailto:info@labelmill.com)

[www.labelmill.com](http://www.labelmill.com)

# TABLE OF CONTENTS

<b>SECTION</b>	<b>PAGE</b>
<b>1. APPLICATOR OVERVIEW</b>	
Introduction	1-01
General System Specifications	1-02
Inventory List	1-03
Print & Apply Component Description	1-04
User Responsibility	1-05
Safety	1-05
<b>2. SETUP AND OPERATION</b>	
Web Routing	2-01
Thermal Print Head Label Loading	2-03
Thermal Ribbon Loading	2-03
Label Sensor Adjustment	2-03
Take Up Unit Assembly	2-04
Clutch Assembly Adjustment	2-05
Hand Held Labeler Interface <b>HLI-200</b>	2-06
Accessory Connections Control Box	2-07
T-52 Photo Eye	2-08
Air Assist	2-09
T-150 Mounting Stand	2-10
T-Stand Adjustments	2-11
Tamp Operation	2-12
Valve Pack / Regulator Adjustments	2-13
Optional Applicator Modules	2-14
<b>3. CONTROL BOX</b>	
Programming	3-01
System Editor	3-02
Programming Menus	3-03
Key Definitions	3-05
Set Up Of Key Features	3-06
Logic Board / Description of I/O	3-08
E-Stop Connection	3-12
<b>4. CLEANING &amp; MAINTENANCE</b>	
Troubleshooting	4-01
Fault Codes	4-02
Replacing Main Power Fuse	4-03

## SECTION 1

# APPLICATOR OVERVIEW

Introduction	1-01
General System Specifications	1-02
Inventory List	1-03
Print & Apply Component Description	1-04
User Responsibility	1-05
Safety	1-05

# LABELMILL LM3612

## THERMAL PRINTER/APPLICATOR SYSTEM

### INTRODUCTION

The **LabelMill LM3612** is a state of the art THERMAL PRINTER & APPLICATOR SYSTEM created with maximum flexibility for your AUTOMATIC LABELING NEEDS. The unit will print and apply high quality labels and bar codes to your product at print speeds up to 14"/sec. and apply at speeds up to 90 labels/min.

#### OPERATION

The standard configuration is External Computer Mode. The configuration allows label formats to be sent to the standard Centronics Parallel Interface Port, or serial port, on the Printer/Applicator. Once the format is downloaded to the Printer Job Buffer, the system LM3612 can print and apply as normal. Standard industry label software packages can be used in conjunction with a PC to design and load label design.

## SYSTEM SPECIFICATIONS

<b>PRINT SPEED</b>	Up to 14"/second and approx. 90 labels/min. (Varies depending on label and product size.)
<b>BAR CODES</b>	Linear and Two-Dimensional Barcodes
<b>BAR CODE RATIOS</b>	1:2, 1:2.5, 1:3 or individually programmable bar code widths
<b>HUMAN READABLE FONTS</b>	OEM Standard Fonts, Firmware Support for Downloadable TrueType Fonts, and Additional Fonts Available
<b>LABEL ROLL CAPACITY</b>	12" Max. outside diameter wound on a 3" diameter core. Die cut waste removed with a minimum of 1/8" separation between labels in running direction.
<b>LABEL SIZE</b>	Minimum: 0.625" wide x 0.50" long Maximum: 6.6" wide x 39" long
<b>MAXIMUM PRINT AREA</b>	6.6" wide x 39" long (Varies dependent upon system configuration)
<b>LABEL PLACEMENT ACCURACY</b>	Up to + or - 1/32" (1mm) when labels are produced to specifications and product handling is controlled.
<b>PRINTING METHOD</b>	Thermal Transfer or Direct Thermal Right-Hand or Left-Hand
<b>INTERFACE</b>	Standard Centronics Parallel Port Standard RS-232C Serial Port, Ethernet port, USB
<b>INTERFACE SENSORS</b>	Ribbon out Product Sensor-Photo Eye-Limit Switch PLC input
<b>ELECTRICAL</b>	115VAC/60 Hz-250 W idle, 600 W running.
<b>AIR REQUIREMENT</b>	80 psi/3 cfm
<b>SIZE</b>	23" T x 30" W x 23-3/8" D
<b>ENVIRONMENT</b>	Operating Temp. 50-95 F (10-35 C) 15-85% RH. non-condensing
<b>WEIGHT</b>	60 lb. Nominal (with U-Arms)

\*Options available

**INVENTORY LIST****QTY.    Description**

- 1    Print & Apply Assembly
- 1    U-Arm Mount
- 1    Power Cord
- 1    Model 3612 Operators Manual (USB)
- 1    Extra Cardboard Ribbon Core
- 1    Product Switch (specified)
  - a. Manual Limit Switch (optional)
  - b. Photo Switch (optional)

**TOOLS REQUIRED FOR ASSEMBLY**

- 3/32" ALLEN WRENCH
- 3/4" WRENCH
- 1-1/8" WRENCH

## COMPONENT DESCRIPTION / LOCATION

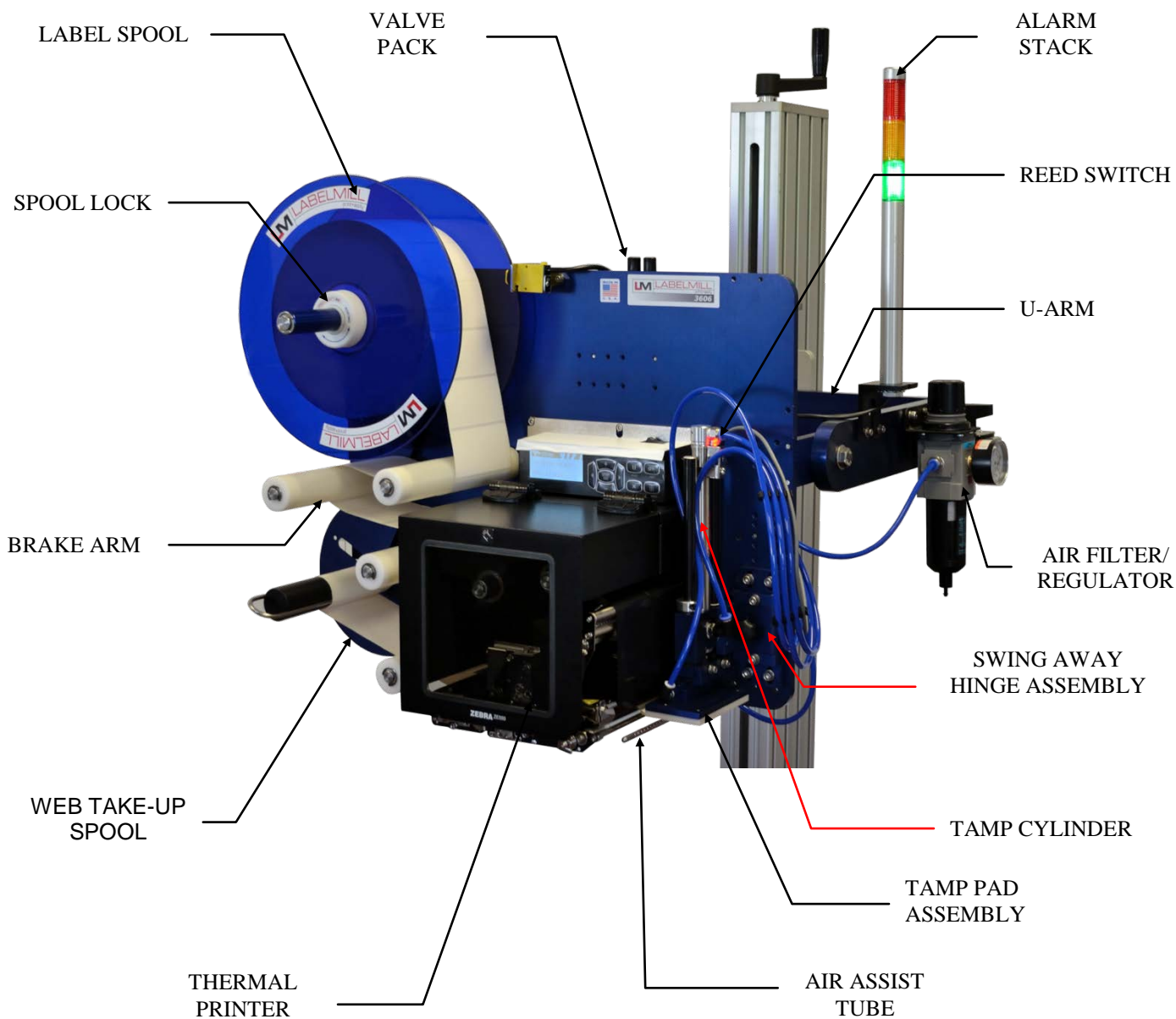

## USER RESPONSIBILITY

This equipment will perform in conformity with the description thereof contained in this manual and accompanying labels and / or inserts when installed, operated, maintained, and repaired in accordance with the instructions provided. This equipment must be checked periodically. Defective equipment should not be used. Parts that are broken, missing, plainly worn, distorted, or contaminated should be replaced immediately. Should such repair or replacement become necessary, we recommend that a request for service advice be made.

This equipment or any of its parts should not be altered without the prior written approval of LabelMill. The user of this equipment shall have the sole responsibility for any malfunctions which results from improper use, faulty maintenance, damage, improper repair or alteration by anyone other than LabelMill. or a service facility designated by LabelMill.

## SAFETY

Only qualified personnel should use this equipment.

Before installing, inspecting or servicing equipment, turn OFF all power and air controls at the source and lock out in accordance with OSHA Standards.

Be sure all external electrically conductive parts are connected to a good electrical ground.

Never handle live electrical equipment with bare hands while standing in water, or while hands and feet are wet.

Dangerous electrical shock can result.

Whenever the equipment is unattended, turn off all control and power supply switches.

Keep equipment clean and in good operating condition. Promptly repair or replace all worn or damaged hoses, cables or parts.

Do not make any repairs to equipment unless you are fully qualified.

This equipment contains fast moving parts, which may move without warning. Keep hands, loose hair and clothes clear of machines at all times.

Never place hands or any other body parts under the label platen at any time.

This equipment uses compressed air. Proper care and maintenance must be taken when handling compressed air and its components.

These precautions are further detailed and explained where specifically required in this manual.

---

 **WARNING****READ AND UNDERSTAND THESE INSTRUCTIONS**

Protect yourself and others. Be sure this information is read and understood by all operators.

**ELECTRICAL SHOCK CAN KILL!**

Do not touch live electrical parts with bare skin or work with gloves or wet clothing.

**NOISE CAN DAMAGE HEARING!**

Wear proper ear protection.

---



## SECTION 2

# SETUP AND OPERATION

Web Routing	2-01
Thermal Print Head Label Loading	2-03
Thermal Ribbon Loading	2-03
Label Sensor Adjustment	2-03
Take Up Unit Assembly	2-04
Clutch Assembly Adjustment	2-05
Operator Interface (HLI-200)	2-06
Accessory Connector Panel	2-07
T-52 Photo Eye	2-08
Air Assist	2-09
T-150 Mobile Mounting Stand	2-10
T-Stand Adjustment	2-11
Tamp Operation	2-12
Valve Pack / Regulator Adjustments	2-13
Optional Tamp Module Configuration	2-14
Optional Corner-Wrap Module Configuration	2-15
Optional Adjacent Panel Module Configuration	2-16
Optional Blow-On Module Configuration	2-17
Optional Table-Top Configuration	2-18

## WEB ROUTING (Right Hand Configuration Shown Below)

Step	Operation
1	Load web onto label storage spool (A) so it unloads in a clockwise direction.
2	Feed the web to the right around guide roller (B), to the left and around brake arm (C), to the right of roller (D) and to the left and below roller guide (E).
3	Feed the web into the thermal printer.
4	Finish the process by loading the waste backing paper onto the web take up spool (F). The take up spool rotates in a clockwise direction.
5	Adjust the (2) plastic web guide clips so the web is guided straight and even. Make sure clips do not bind the web.

\*For a detailed illustration of this procedure, see Figure 2-1 below.

FIGURE 2-1

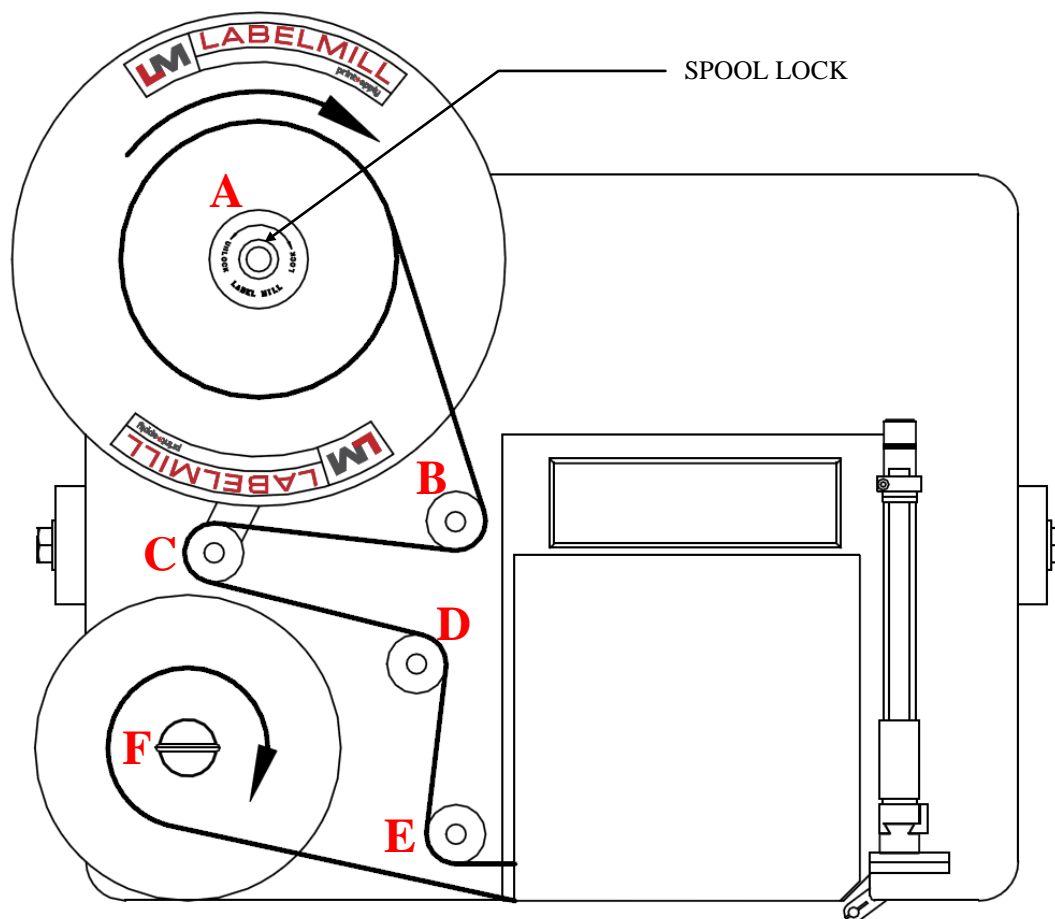

## SUPPLY SPOOL



### SPOOL LOCK REMOVAL:

To remove the label storage spool, turn the spool lock counterclockwise until you reach a stop. The spool will now slide off. To secure the spool, simply turn the spool lock clockwise until snug. **DO NOT** over tighten!

## LOADING THERMAL PRINT HEAD

REFER TO PRINTER MANUAL

## LABEL & RIBBON ROUTING

REFER TO PRINTER MANUAL

## THERMAL RIBBON LOADING

REFER TO PRINTER MANUAL

***NOTE: The printer will not operate unless the front cover is in the fully closed position. For your continued safety, do not override the front cover interlock switch.***

## LABEL SENSOR ADJUSTMENT

REFER TO PRINTER MANUAL

## TAKE-UP UNIT ASSEMBLY

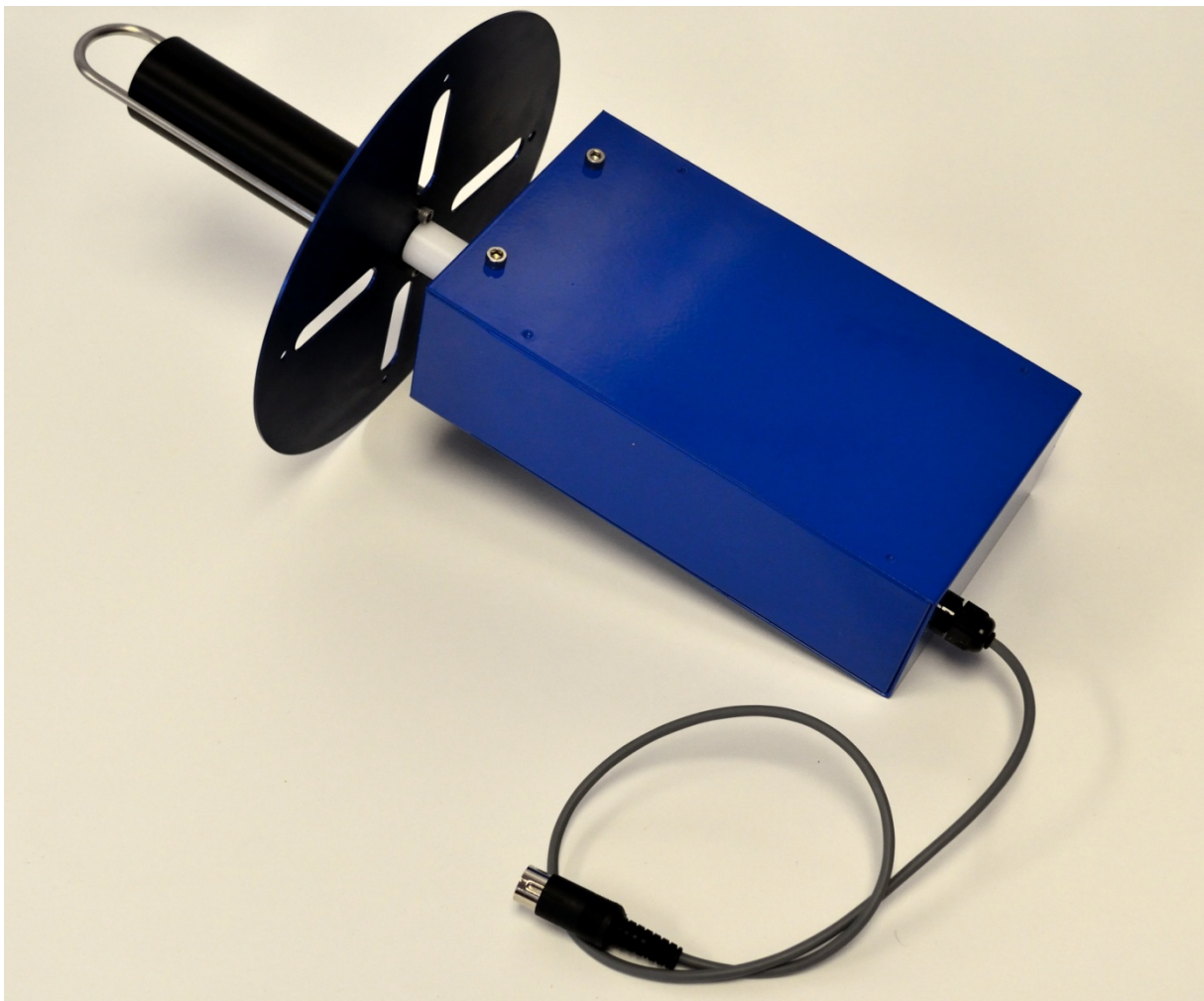

The Take-Up Assembly is located on the backside of the main panel. To adjust the clutch, the side panels must be removed to gain access. The mounting bolts for the Take-Up Assembly can be found directly behind the aluminum spool.

**WARNING!!!** Be sure power is off before performing any service.

## CLUTCH ADJUSTMENT

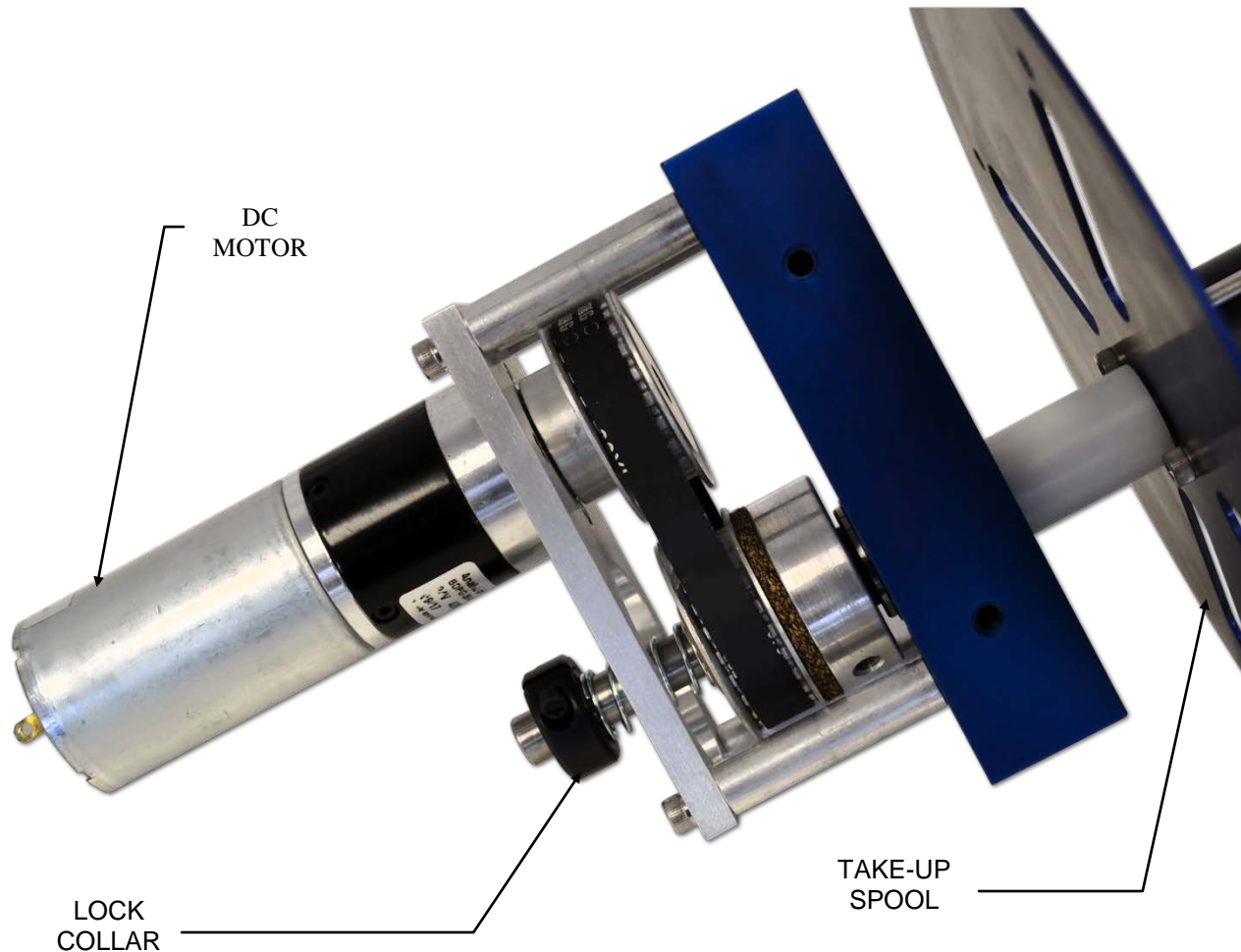

To reduce waste web tension, move the lock collar 1/32" away from the take-up spool. To increase web tension, move the lock collar 1/32" toward the take-up spool.

**CAUTION!** Too much web tension may cause web breakage, label drifting, or premature failure of the take-up spool assembly.

## HAND HELD LABELER INTERFACE HLI-200



TOUCH-SCREEN  
DISPLAY

INTERFACE PORT

## ACCESSORY CONNECTIONS

LOCATED ON BACK OF LABELER CONTROL ENCLOSURE

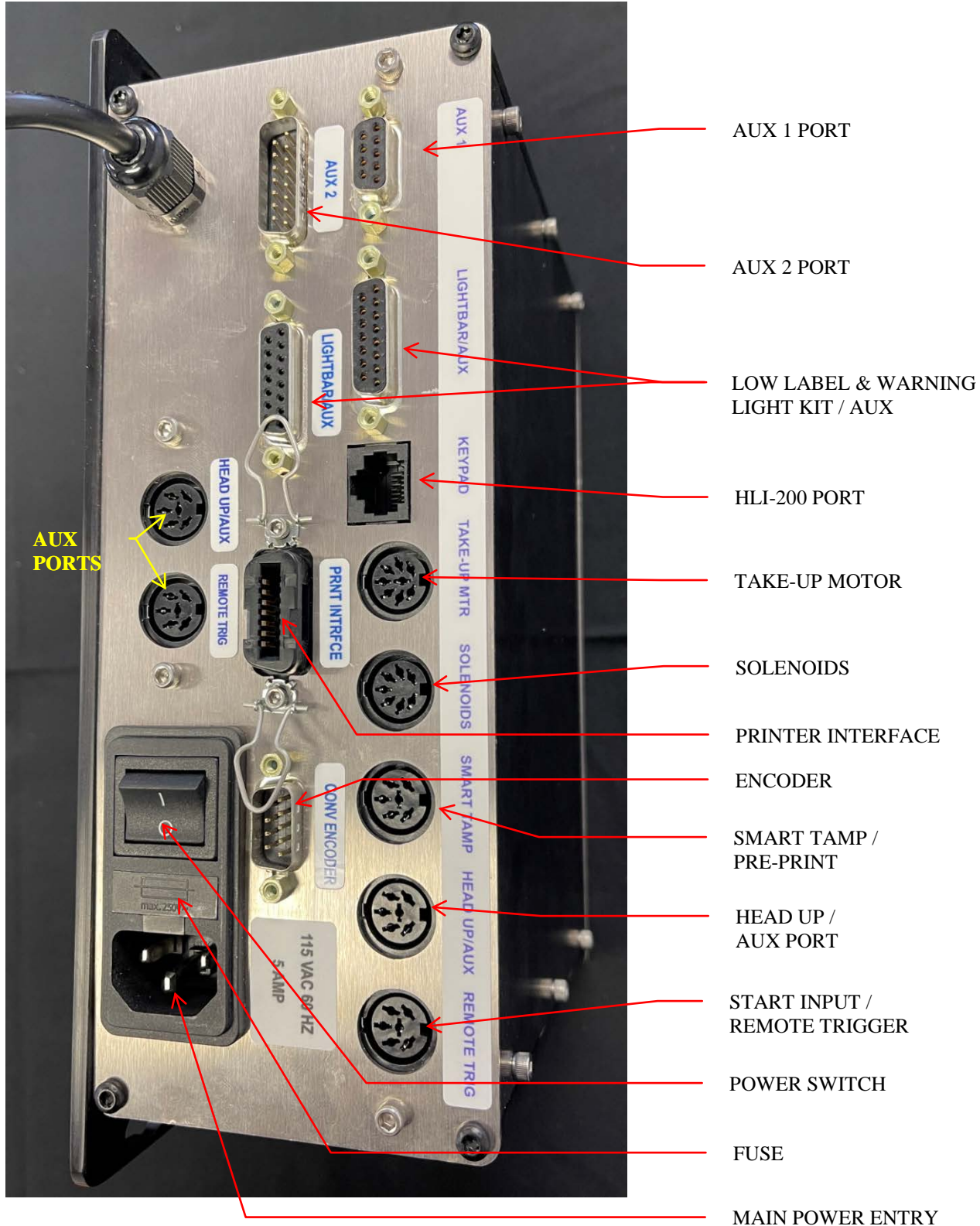

AUX 1 PORT

AUX 2 PORT

LOW LABEL & WARNING  
LIGHT KIT / AUX

HLI-200 PORT

TAKE-UP MOTOR

SOLENOIDS

PRINTER INTERFACE

ENCODER

SMART TAMP /  
PRE-PRINT

HEAD UP /  
AUX PORT

START INPUT /  
REMOTE TRIGGER

POWER SWITCH

FUSE

MAIN POWER ENTRY

AUX  
PORTS



## T-52 PHOTO EYE (Remote Trigger)



\*\*\*Refer to Section 3 for I/O details\*\*\*

## AIR ASSIST TUBE

The Air Assist Tube must be adjusted to clear the trailing edge of the printed labels and the Label Platen. An adjustment screw is used to adjust the position of the air holes in relation to the labels. An angle of 45 degrees is required.

One slot is provided to make the appropriate adjustments desired.

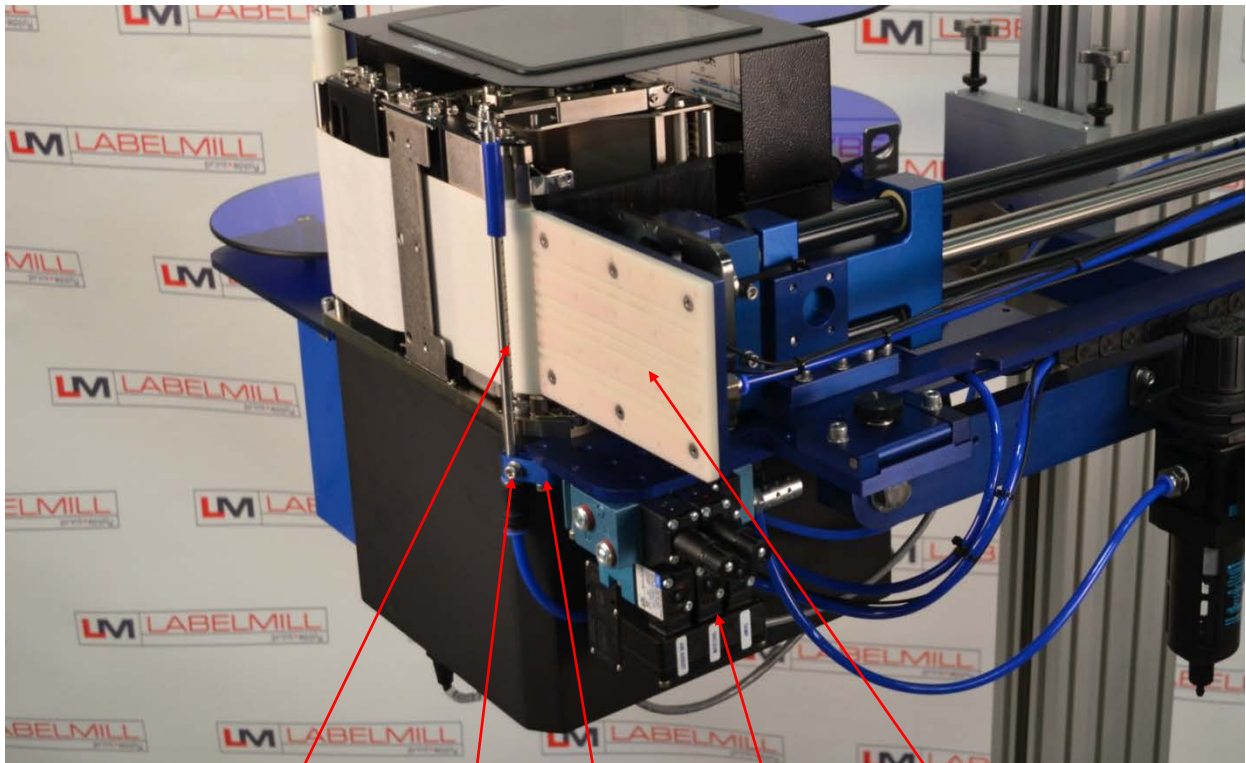
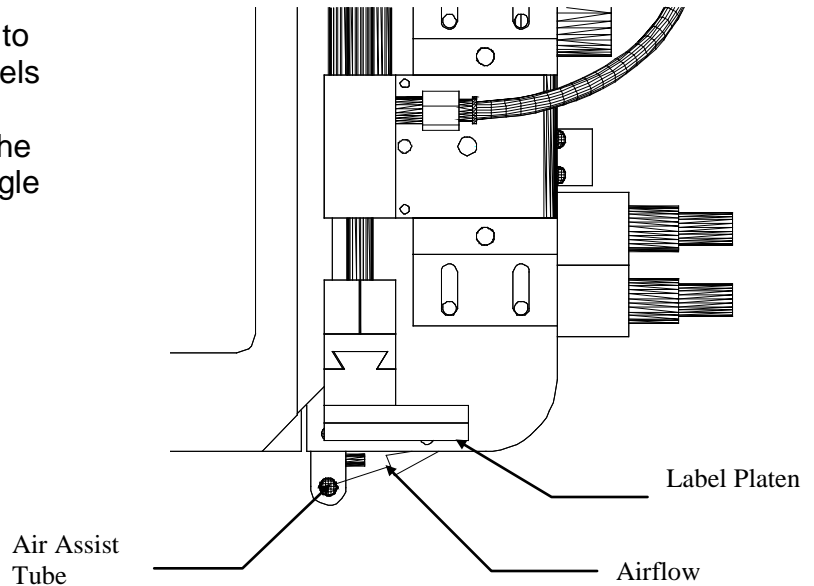

Air Assist Tube

Clamp screw

Mount Bracket

Valve Pack

Label Platen

## OPTIONAL T-150 MOUNTING STAND



## T-STAND ADJUSTMENT

Column Crank

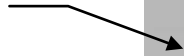

Column Lock

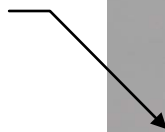

## TAMP UNIT OPERATION

### Tamp Duration

Tamp duration is used to provide an on timer for the solenoid valve on the main tamp cylinder. The delay on standard versions can be programmed from 0 to 30.000 seconds in 1/1000 of a second accuracy. This allows for easy change over from one product height to another without physically changing the height of the unit. It also allows for precise adjustments of how close the tamp head comes to the product.

There is flow control adjustment for the valves. It may be necessary to adjust the flow rate on the tamp solenoid for optimum performance after installation. The adjustment is performed as shown below. They are set at the factory. The regulators on the vacuum, air assist, and flag valves are for increasing or decreasing the air pressure as necessary for proper operation. Note: Flag Regulator not shown below – only supplied with flag applicators.

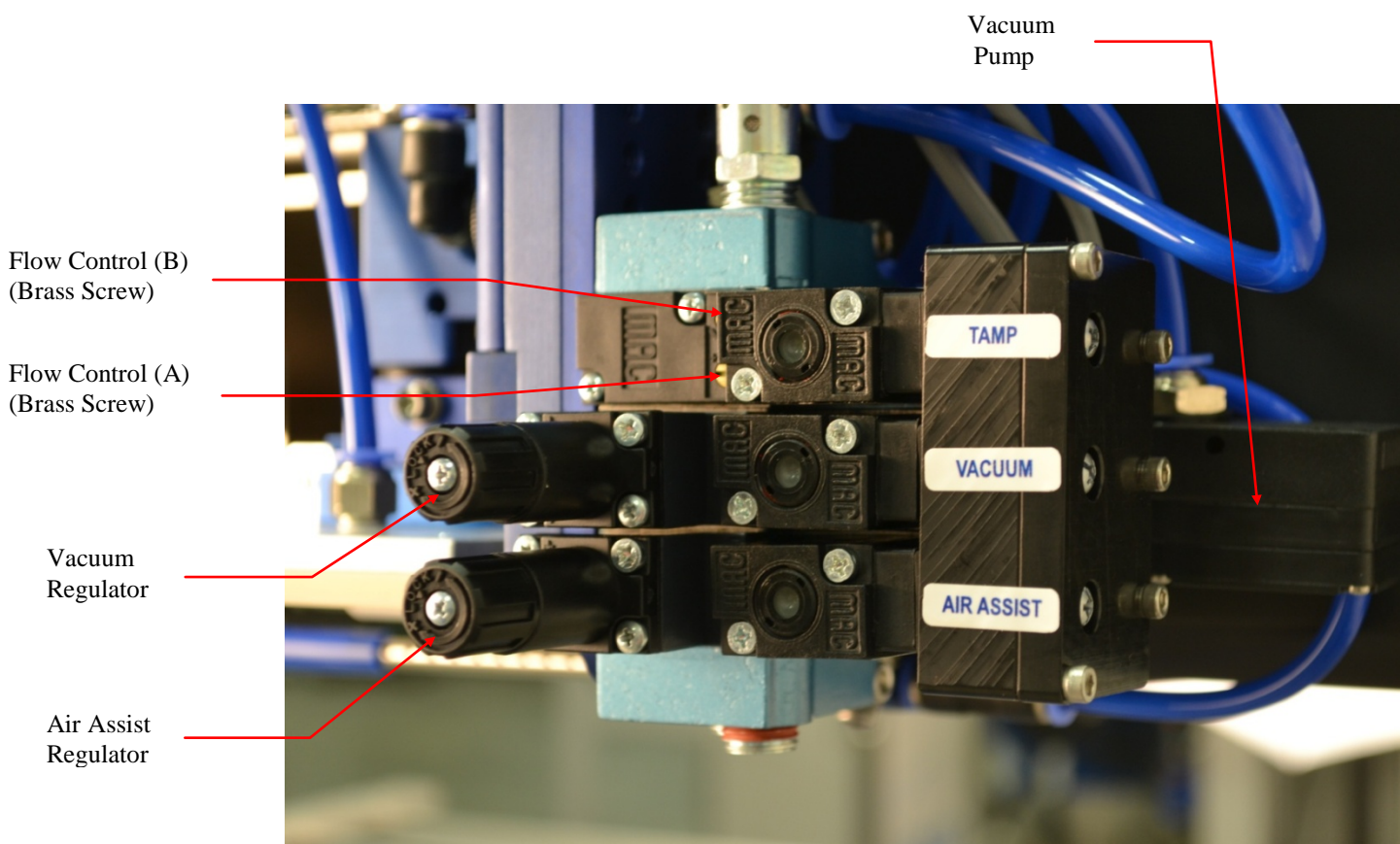

## TAMP FLOW CONTROL ADJUSTMENT

Regulator Adjustment:

**Clockwise** - Increase pressure    **Counterclockwise** - Decrease pressure

### **FLOW CONTROLS** (tamp and flag applications)

Control A: This is used to adjust the pressure that controls the tamp cylinder in the upward direction.

Control B: Controls the tamp cylinder in the downward direction.

### **Valve Pack Regulators**

#### **MAIN AIR REGULATOR**

Controls maximum air pressure available to entire applicator. Should be set between 40 and 80 PSI.

#### **FLAG REGULATOR**

The flag regulator is used to adjust the pressure that the flag jaws apply to the label as it is applied.

#### **VACUUM REGULATOR** (only used on the flag and tamp applicator system)

The vacuum regulator is used to control the vacuum that is used to hold the label to the flag jaws or the tamp pad.

#### **AIR ASSIST REGULATOR**

The air assist regulator is used to change the pressure that is applied to the blow tube. The blow tube is below the front edge of the peeler plate and is used to help “push” the label onto the bottom of the tamp pad or the flag jaws.

## OPTIONAL TAMP APPLICATOR (Right Hand Configuration Below)

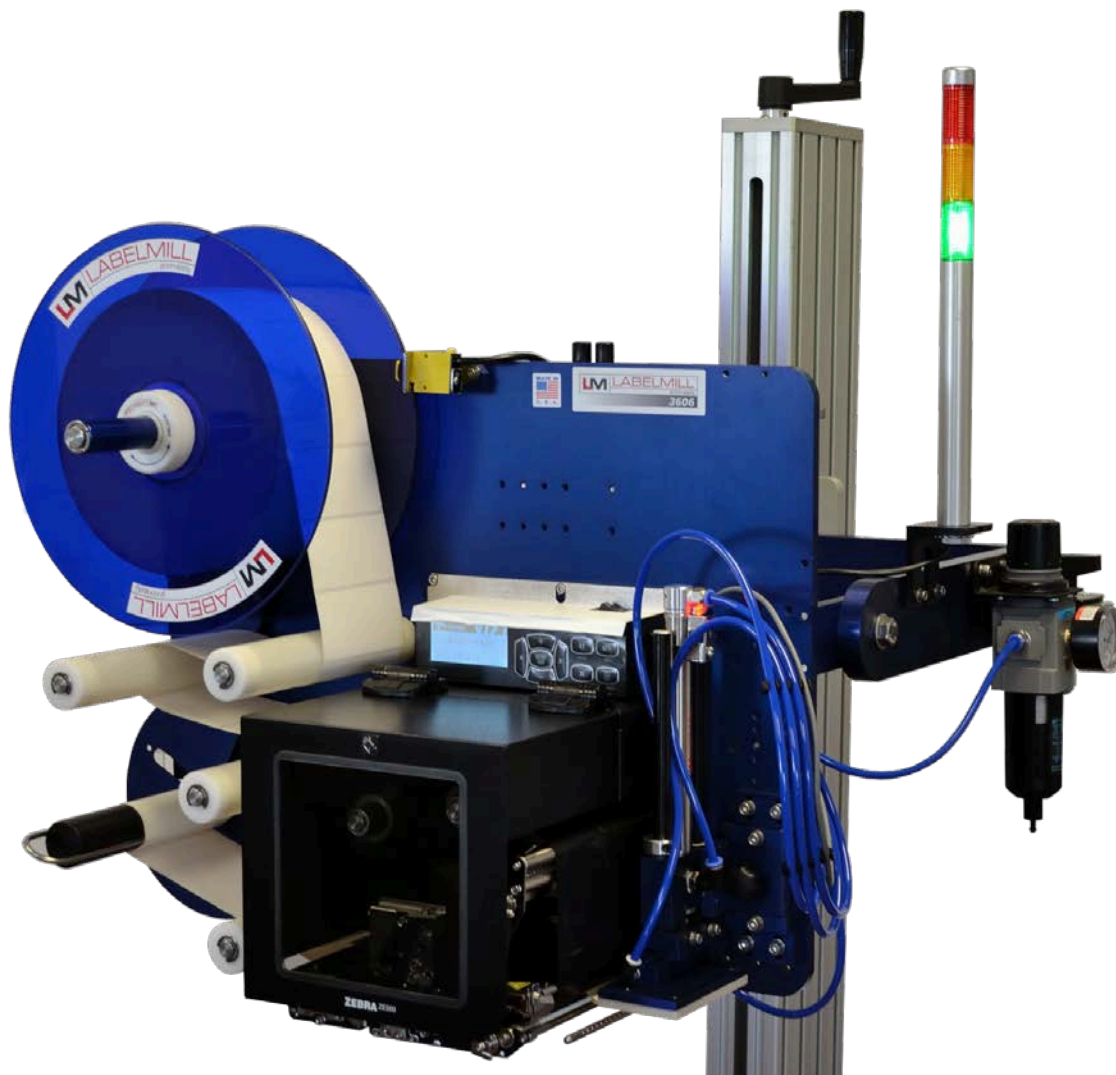

## OPTIONAL CORNER-WRAP APPLICATOR (Left Hand Configuration Below)





## OPTIONAL ADJACENT PANEL APPLICATOR (Right Hand Configuration Below)



## OPTIONAL BLOW-ON APPLICATOR (Right Hand Configuration Below)

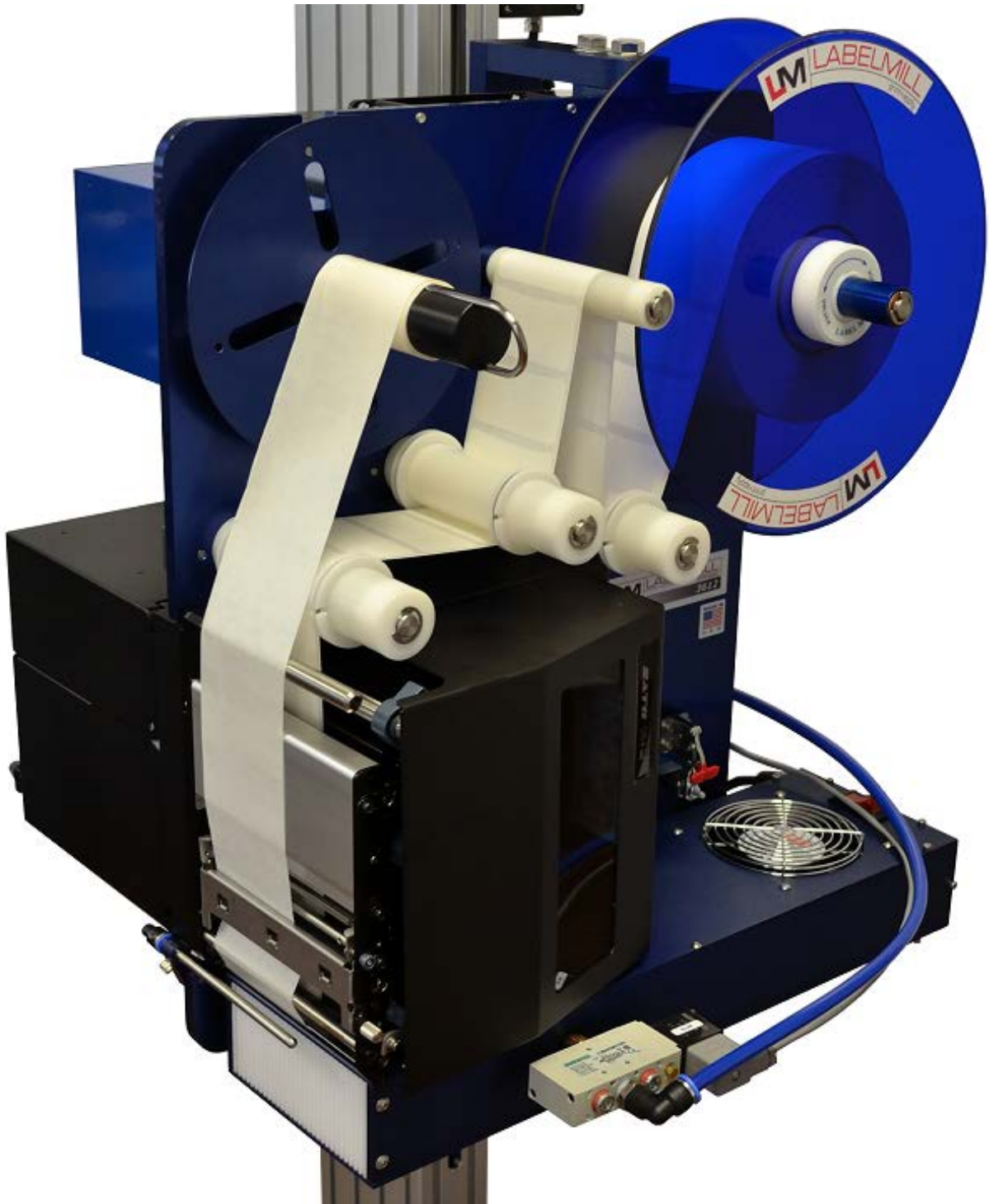

## OPTIONAL TABLE-TOP APPLICATOR

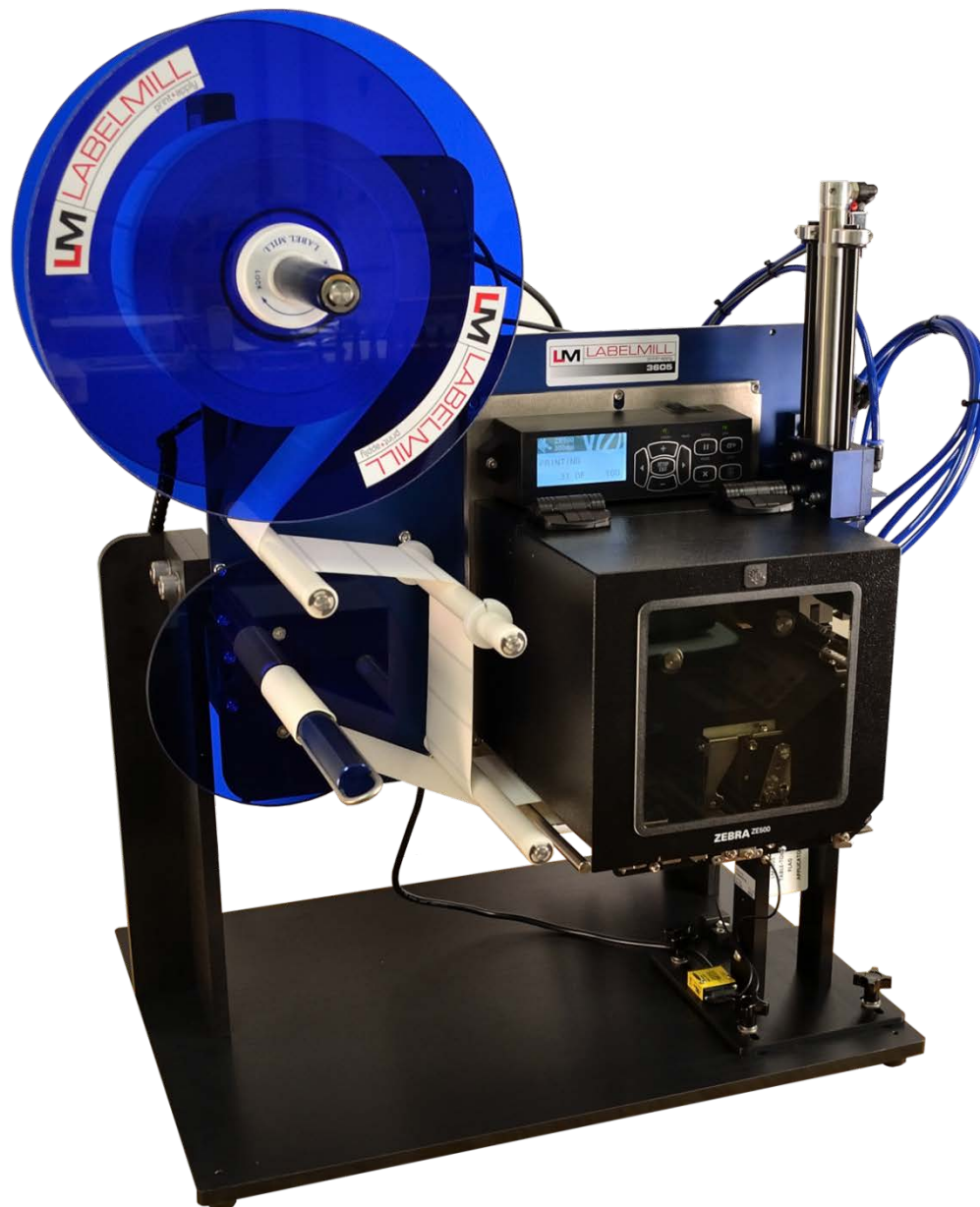

## SECTION 3

### CONTROL BOX

Programming	3-01
System Editor	3-02
Programming Menus	3-03
Key Definitions	3-05
Quick Start & Set Up of Key Features	3-06
Logic Board / Description of I/O	3-08
E-Stop Connection	3-12

## PROGRAMMING

All programming is performed via the **HLI-200** keypad and display. All programmed settings are backed in nonvolatile memory and are not lost when the unit is powered off.

Upon power up of the control, the screen will display *MODEL NUMBER & REVISION* of the HLI-200 and then the *MODEL NUMBER & REVISION* of the labeler control. After this, the screen will now display the "Total" counter, "Batch" counter, and Cycle time in the center of the screen. Error messages or warning will be displayed in the box at the bottom of the screen. The top of the screen allows you to Start, Stop, Enable, or Disable the system, and also shows the current state of the system.

### KEY FUNCTIONS:

#### START:

- Start key will initialize the application cycle.

#### STOP:

- Stop key will abort the cycle only when not in the program menu.

#### PRINT: (NOT SHOWN)

- Print key will signal the connected print engine to dispense (1) printed label. (Print files must be loaded into Print Buffer)

#### ENABLE:

- Enable key will "Enable" the system after it has been disabled.

#### DISABLE:

- Disable key will prevent the system from accepting trigger inputs.

#### CLEAR:

- Clear key will clear an error status

#### PROGRAM:

- Program key will enter the system editor.

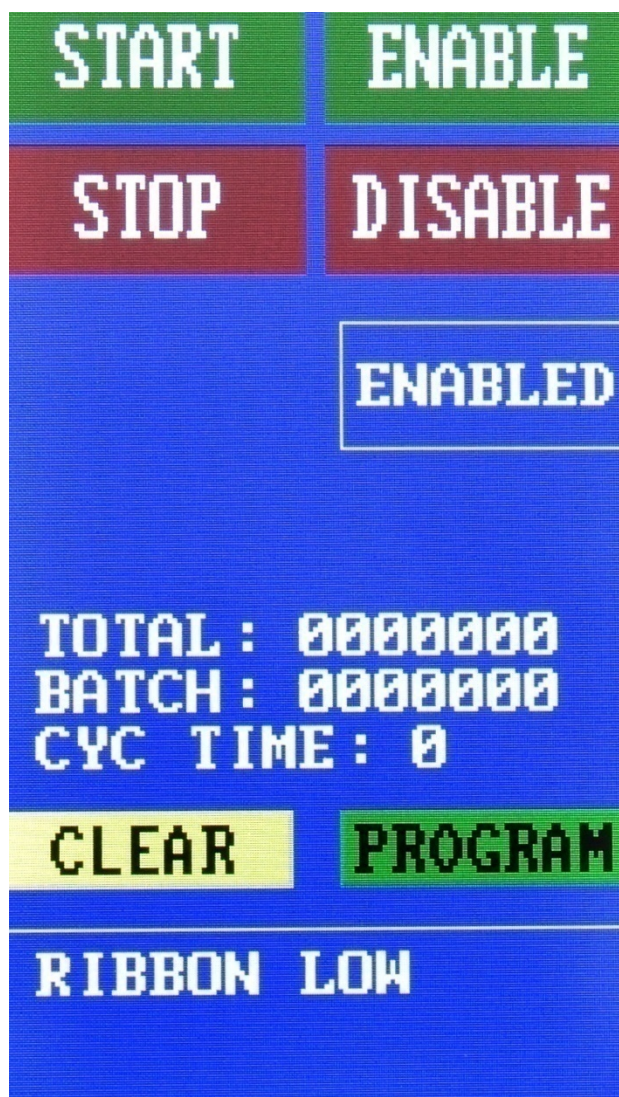

**SYSTEM EDITOR**

Press the "Program" button to enter the system editor. Here you will find the following options:

**I/O Panel**

**Product Sensor**

**Takeup**

**Tamp Setup**

**Counters**

**Cycle Type**

**Job Storage**

**Set Defaults**

**Password**

**EXIT**

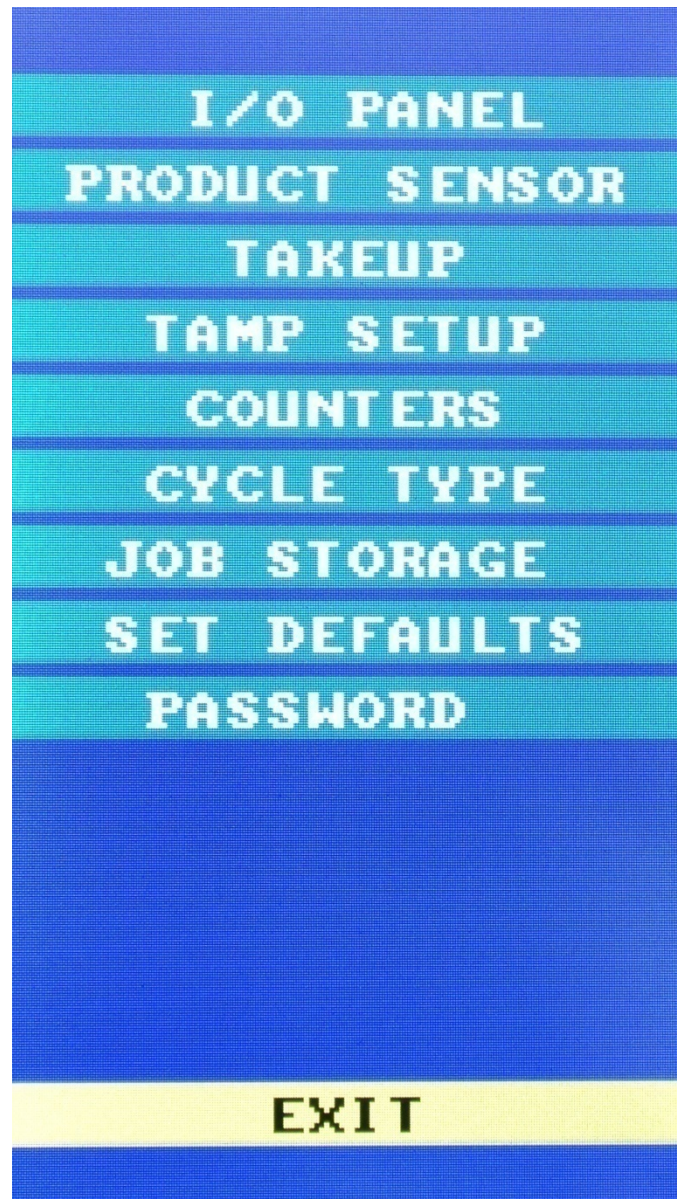

Use the "Exit" key to save any changes and return to Run Mode.

## SYSTEM PROGRAMMING

### • I/O PANEL

Displays the status of the inputs and outputs. X = On    0 = Off

### • PRODUCT SENSOR

This is an external device that when “activated” starts the application cycle.

#### *PROGRAMMABLE BLOCKS:*

Product Delay – Delays the application of the label (x) seconds after the sensor has been activated.

Trigger Edge – Designates whether product sensor is activated at the leading or trailing edge of the product.

Trig On Debounce – Programmable time that a trigger signal must be held for a start cycle to activate.

Trig Off Debounce – Programmable time that input triggers will be ignored for after a completed cycle.

No. of Multiple Feed – How many labels are applied to one product with one signal.

Interval Delay – Amount of time in seconds between multiple fed labels.

**Note:** Only active if Multiple Feed quantity is 2 or higher.

Multiple Feed List - Programmable delay between each programmed multiple feed.

### • TAKE UP

This is used to delay the start and stop of the take up motor.

#### *PROGRAMMABLE BLOCKS:*

On Delay – Delays (x) seconds after start print before starting take up motor.

Off Delay – Take up runs (x) seconds after end print signal is received from printer.

Jog Takeup – Press the JOG TAKEUP button to jog the motor.

### • TAMP SET UP

This is used to adjust the different variables related to the tamp cycle.

#### *PROGRAMMABLE BLOCKS:*

Tamp Duration – Used to adjust the time that the tamp cylinder valve is actuated. (0.000 to 10.000)

Flag Duration – Used to adjust the time the flag jaws are held open after label application. (00.00 to 30.000)

Head Up Switch Type – type: **normally open**-standard, none

Head Up Debounce – Debounce is used to allow time for the tamp cylinder to settle on return. (0 to 0.500)

Vacuum Release – Used to release label when tamping on light products. (0.000 to 10.000)

Vacuum Delay On – Used to reduce label flutter when feeding large labels while tamping. (0.000 to 6.000)

Tamp Sync Logic – Used to reverse tamp sync outputs.

Air Assist Delay -- Used to delay the Air Assist output (0.000 to 1.000 seconds)

### • COUNTER

Used to reset the internal counter of the control.

#### *PROGRAMMABLE BLOCKS:*

Batch Preset - Used to set Batch Counter. Once reached, the applicator will Inhibit.

Clear Batch Counter - Used to clear the programmed batch counter.

Clear Total Counter - Clears the system Total Counter

**• CYCLE TYPE**

Cycle Type determines the application type and sequence in relation to the label feed. Use the "Up" or "Down" button to select the appropriate cycle type. "Tamp Before Feed" is the default setting.

**PROGRAMMABLE BLOCKS:**

Print Repeat - Activates the "Print Repeat" signal to the print engine (Engine must also be enabled)

Printer Ready - Activates the "Printer Ready" signal.

Printer Fault Timer - Programmable fault timer for "Printer Ready" signal. (0.000 to 9.000)

- Available Cycle Types
  - Feed Only
  - Tamp Before Label Feed
  - Tamp After Label Feed
  - Blow On Before Label Feed
  - Blow On After Label Feed
  - 1st Trigger Feed, Product Switch Tamp
  - 1st Trigger Feed, Product Switch Blow
  - Clam Shell Module Before Feed
  - Clam Shell Module After Feed

**• ENCODER**

Provides a more consistent way to apply labels to a product. With this option a distance from the trigger point can be set at which the label is to be applied. Note: optional encoder must be used with this feature.

**PROGRAMMABLE BLOCKS:**

Encoder – Used to toggle the encoder option on or off.

Trigger Mode - Selectable "Product Delay" or "Distance" mode.

Trigger Distance – Used to apply the label a certain distance away from the trigger point.

Enc lines/inch – Tells how many pulses the encoder will count with 1 inch of travel. (25 to 500 counts per inch)

View Conveyor IPM - Allows operator to view current speed of the encoder/conveyor.

**• JOB STORAGE**

Used to store frequently used settings pertaining to different labeling jobs. Up to (6) jobs can be stored.

**PROGRAMMABLE BLOCKS:**

Restore A Job – Recalls settings of a saved job.

Save A Job – Stores settings for the active job.

Delete A Job – Deletes a saved job.

**• SET DEFAULTS**

This setting will return the controller to the default settings.

**• PASSWORD**

The PASSWORD is used to lock the menus of the control. This option is used to prevent unauthorized access to variable data. When shipped from the factory, the pass word is to 7074 and NO MENUS are locked. The password cannot be changed.



## KEY DEFINITIONS

- **ASYNCHRONOUS OPERATION** – The term “ASYNCHRONOUS OPERATION” is used because the speed of the printer applicator motor (label speed) does not necessarily match the speed of the product conveyor. In other words their speed is set independently of one another and has NO interrelation. The 3612 can only be configured in asynchronous operation.
- **SYNCHRONOUS OPERATION** - The term “SYNCHRONOUS OPERATION” is used because the speed of the applicator motor (label speed) is matched to the speed of the product conveyor. In order to accomplish this, an encoder is used to monitor the speed and distance the product conveyor travels. In order for this feature to function the “CONVEYOR LOCK” mode must be turned on. In synchronous operation, the applicator motor is **ELECTRONICALLY GEARED** to the product conveyor. **The 3612 CANNOT be configured in synchronous operation.**
- **START COMPENSATION** – Start compensation compensates for the reaction time of the Label Mill control and start signal from the product switch. The purpose of start compensation is to maintain label placement on a product that is traveling at different speeds. An example of this is a conveyor that accelerates on start up and decelerates to a stop. At high speeds an uncompensated system would apply a label too late and the label would be placed too far back on the product. Linear interpolation is used to correct this problem. The start compensation corrects this error by adding an offset distance at LOW speeds, since it is not possible to apply any correction at high speed. **Note: Start compensation ONLY effects label placement on product.**
- **ELECTRONIC GEARING** – Electronic gearing is a function of the product encoder and the LabelMill control. This is used to match the speed of the applicator to the product conveyor. Electronic gearing is similar to mechanical gearing in that there is a gear ratio and the change of speed of one affects the speed of the other. This feature is part of the Synchronous feed mode. In order for this to operate properly, the correct number of lines per inch of product travel must be entered into the ENC LINES/INCH in encoder setup menu.
- **ENCODER** – AN ENCODER is a device that is used to monitor the speed of an external device like a product conveyor. The reason this speed is monitored is to match the speed of the label applicator to the product speed. An encoder uses “LINES or COUNTS” per revolution in order to track speed and distance. Note that lines per revolution are also referred to as counts per revolution. These counts are feed into the LABEL MILL control to be processed for the different features that require this feedback.
- **ENCODER OVERRIDE** – This feature is used in conjunction with ELECTRONIC GEARING. This feature is used to fine-tune the ratio of the applicator to the product conveyor.
- **TRIGGER DIST** – TRIGGER DISTANCE is used in conjunction with the encoder feature. Trigger distance is similar to product delay in that it is used to electronically move the placement of the label on the product. When the encoder feature is used, the product delay feature is rendered inactive. Trigger distance will move the label placement in inches (00.00).
- **PRODUCT DELAY** is NOT used in conjunction with the encoder feature. Product delay is similar to trigger distance in that it is used to electronically move the placement of the label on the product. Product delay will move the label placement in time (00.000) seconds. Because the product delay feature utilizes time, the speed of the product **MUST** remain constant. A product traveling at a higher velocity will travel further in a given time, thus effecting the placement of the label.

## QUICK START GENERAL SETUP (TAMP APPLICATION)

1. Inspect applicator system and verify all cables are installed properly.
2. Web system with labels.
3. Turn power switch on.
4. Turn printer on & load label files.
5. Press "PROGRAM"
6. Enter Defaults.
7. Select "PRODUCT SENSOR"
8. Enter sensor parameters.
9. Press "TAMP SETUP"
10. Set tamp duration to .500 and set Head up switch to "N.O."
11. Press "CYCLE TYPE"
12. Set cycle type to "Tamp Before Feed"
13. Press "EXIT"
14. System is now ready for set up of advanced features and options.

## SETUP OF KEY FEATURES

### HOW TO SET UP AN ASYNCHRONOUS APPLICATION

- **"TAMP"**

Determine the following and select it in the software

1. Type of application mode. MENU "CYCLE TYPE"
2. Tamp before or after feed (before feed is standard)
3. Enter a value in the tamp duration (start with 00.500).
4. Set head up limit switch, normally open is standard.
5. Use the product delay to "MOVE" the label placement on the product.

The asynchronous application mode is used to apply labels to products that are either stationary or moving at a constant speed when the label application is to take place.

## PRODUCT DELAY

PRODUCT DELAY is NOT used in conjunction with the encoder feature. Product delay is similar to trigger distance in that it is used to electronically move the placement of the label on the product. Product delay will move the label placement in time (00.000). Because the product delay feature utilizes time, the speed of the product MUST be constant and consistent.

1. Set basic applicator up first, refer to quick setup
2. Ensure that applicator is operating properly before starting this procedure.
3. This feature requires the use of an encoder. The appropriate encoder features should be setup prior to this feature.
4. Set Product delay to 00.000
5. Start system and apply label at the desired speed.
6. Check the placement of the label on the product.
7. Measure the OFFSET of the label placement. Note: A label CAN NOT be advanced on the product ONLY moved "back" since the applicator can only delay the product signal.
8. Apply a small delay to the product delay or if too great, it may be necessary to physically move the product switch. Keep product delays to a minimum for best results.
9. Operate system again and measure offset.
10. Apply a small delay to the product delay or reduce if too much.
11. Test again, repeat if necessary until label is in proper registration.
12. Turn back on any options that may have been disabled for setup of this particular feature

## HOW TO APPLY MULTIPLE LABELS TO A SINGLE PRODUCT

Product delay is used to electronically move the placement of the **FIRST** label on the product. Product delay will move the label placement in time (00.000). Because the product delay feature utilizes time, the speed of the product MUST be constant and consistent. This section will explain how to apply more than one label to a single product with a single start signal. MULTIPLE FEED will allow you to select how many labels to be applied.

1. Set basic applicator up first, refer to quick setup
2. Ensure that applicator is operating properly before starting this procedure.
3. Set Product delay to 00.000
4. Start system and apply label at the desired speed.
5. Check the placement of the label on the product.
6. Measure the OFFSET of the label placement. Note: A label CAN NOT be advanced on the product ONLY moved "back" since the applicator can only delay the product signal.
7. Apply a small delay to the product delay or if too great, it may be necessary to physically move the product switch. Keep product delays to a minimum for best results.
8. Operate system again and measure offset.
9. Apply a small delay to the product delay or reduce if too much.
10. Test again; repeat if necessary until label is in proper registration.
11. Go to **MULTIPLE FEED** in PRODUCT SENSOR menu and set the number of labels to be applied to the product.
12. Set the Distance between each label entering a time (0.000) into "**INTERVAL DELAY**"
13. Test the placement of the labels and adjust as necessary. Note: The spacing between each label will be equal. With this feature the space between labels **cannot** be set individually.
14. Note: **TRAILING EDGE TRIGGER** will NOT work with this feature!
15. Note: Product speed fluctuations can effect label placement.
16. Turn back on any options that may have been disabled for setup of this particular feature.

# LOGIC BOARD

## DESCRIPTION OF I/O

### LEGEND

24V OPT: 24V OPTO INPUT WITH INTERNAL 24V COMMON  
 OH: HIGH CURRENT OUTPUT Rated @ 500ma

All user inputs and outputs are “**SINKING**” type.

Example: In order for a status light to illuminate for “Run Status Ok” the light should be wired between pins #1 & #8 on the “Light Bar/Aux” Connector.

REMOTE TRIGGER CONNECTOR (PRODUCT SWITCH)	P7 PIN #	I/O	I/O Monitor ADDRESS
+24vdc	1		
+24vdc	2		
Trigger Input #1	3	Input	X0.0
Pr-Print Input / AUX1	4	Input	X0.1
24v Common	5		
24v Common	6		
Shield			

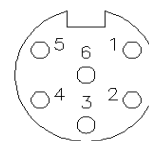

HEAD-UP / AUX IN	P8 PIN #	I/O	I/O Monitor ADDRESS
+24vdc	1		
+24vdc	2		
Head – Up	3	Input	X0.2
Smart Tamp	4	Input	X0.3
24v Common	5		
24v Common	6		
Shield			

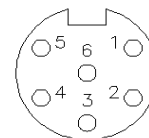

SMART TAMP	P2 PIN #	I/O	ADDRESS
+24vdc	1		
+24vdc	2		
Pre-Print Input / AUX1	3	Input	X0.1
Smart Tamp	4	Input	X0.3
24v Common	5		
24v Common	6		
SHIELD			

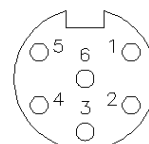

Take-Up	P4 PIN #	I/O	I/O Monitor ADDRESS
Input	1	Input	X0.4
24v Common	2		
N.C.	3		
Take up output	4	Output	Y1.3
N.C.	5		
N.C.	6		
N.C.	7		
+24vdc	8		
Shield			

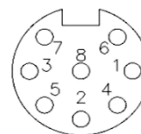

TAMP SOLENOIDS	P6 PIN #	I/O	I/O Monitor ADDRESS
Aux Output #2 / Tamp Slide	1	Output	Y1.7
+24 Volt	2		
No connection	3		
Air Assist Sol 24vdc	4	Output	Y0.0
Vacuum Sol 24vdc	5	Output	Y0.2
Tamp Sol 24vdc	6	Output	Y0.3
Flag Sol 24vdc	7	Output	Y0.1
Shield			

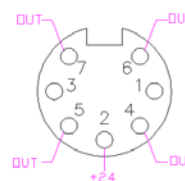

HMI RJ Conn	P3 PIN #	Jumpers
422RX+ (TXB)	1	
422RX- (RXB)	2	
	3	
	4	
24V Common	5	
+24vdc	6	
422TX+	7	
422TX-	8	

LIGHT BAR/AUXILIARY CONNECTOR DB-15 FEMALE	P10 PIN #	INPUT/ OUTPUT	ADDRESS	
+24VDC	1			
+24VDC	2			
24 COM	3			
24 COM	4			
LOW LABEL IN	5	I	X0.5	
ERROR LITE (Red light)	6	O	Y0.6	On=GREEN Off=RED
LOW LABEL (Yellow light)	7	O	Y0.7	
RUN STATUS OK (Green Light)	8	O		Green = /Red
TAMP SYNC OUT	9	O	Y1.1	
INHIBIT IN	10	I	X0.6	
REPRINT / Aux Input #2	11	I	X0.7	
Aux Input #3 / Slide Home Input	12	I	X1.1	
Aux Input #4 / Feed Error Input	13	I	X1.2	
Applicator in cycle output (Applicator Busy)	14	O	Y1.2	
Batch Done Aux Output #1	15	O	Y1.6	

<b>LIGHT BAR/AUXILIARY CONNECTOR DB-15 FEMALE</b>	P10 PIN #	INPUT/ OUTPUT	ADDRESS	
+24VDC	1			
+24VDC	2			
24 COM	3			
24 COM	4			
LOW LABEL IN	5	I	X0.5	
ERROR LITE (Red light)	6	O	Y0.6	On=GREEN Off=RED
LOW LABEL (Yellow light)	7	O	Y0.7	
RUN STATUS OK (Green Light)	8	O		Green = /Red
TAMP SYNC OUT	9	O	Y1.1	
INHIBIT IN	10	I	X0.6	
REPRINT / Aux Input #2	11	I	X0.7	
Aux Input #3 / Slide Home Input	12	I	X1.1	
Aux Input #4 / Feed Error Input	13	I	X1.2	
Applicator in cycle output (Applicator Busy)	14	O	Y1.2	
Batch Done Aux Output #1	15	O	Y1.6	

<b>AUXILIARY CONNECTOR 3rd DB-15 MALE</b>	DB15 PIN #	INPUT/ OUTPUT	ADDRESS	
AUX 232 TXC Port C	1	O		RS232 Output
GND	2			
GND	3			
Batch Done Aux Output #1	4	O	Y1.6	
REPRINT / Aux Input #2	5	I	X0.7	
Aux Input #4 / Feed Error Input	6	I	X1.2	
+24V	7			
+24V	8			
AUX 232 RXC Port C	9	I		RS232 Input
24MCR	10			24 Volts when not in E-Stop
24MCR	11			24 Volts when not in E-Stop
Estop relay	12	relay		Used to seal E-Stop
Aux Input #3	13	I	X1.1	
Tamp / Aux Output #2 High current	14	O	Y1.7	
+24V	15			

<b>COMM. 2 RS- 232 DB9 Female</b>	P11 PIN #	INPUT/ OUTPUT	ADDRESS	
<b>Serial Plus Port</b>				
SHIELD	1			
+485 RS232 XMIT (port D) to motor	2			
-485 RS232 RECV (port D) to motor	3			
24C	4			
24C	5			
Aux Output #2 High current	6	O	Y1.7	
Aux Input #2	7	I	X0.7	
+24	8			
+24	9			

<b>PRINT AND APPLY INTERFACE 14 pin Centronix</b>	<b>P9 PIN #</b>	<b>I/O</b>	<b>I/O Monitor ADDRESS</b>
Paper End	1	Input	X1.3
Printer Ground	2		
Ribbon End	3	Input	X1.4
Printer Error	4	Input	X1.5
Print Start	5	Output	Y0.4
Print End	6	Input	X1.6
Reprint	7	Output	Y0.5
	8		
ONLINE (Sato Only) (Zebra Data Ready)	9	Input	X1.7
Ribbon Near End	10	Input	X1.0
	11		
	12		
+5vdc From Printer	13		
	14		
Shield			

<b>DB9 Male Encoder</b>	<b>P14 PIN #</b>	<b>I/O</b>	<b>I/O Monitor ADDRESS</b>
A+	1	I	
A-	2	I	
B+	3	I	
B-	4	I	
+5V	5		
GND	6		
GND	7		
No Connection	8		
No Connection	9		

## E-Stop Connection

### Sample E-Stop Wiring:

**Note:** Internal E-Stop Jumper must be removed for this option to be utilized.

**When interfacing to an automated system, the reset button is not required.**

**Connect the automated systems safety relay contacts to pins 12 and 15.**

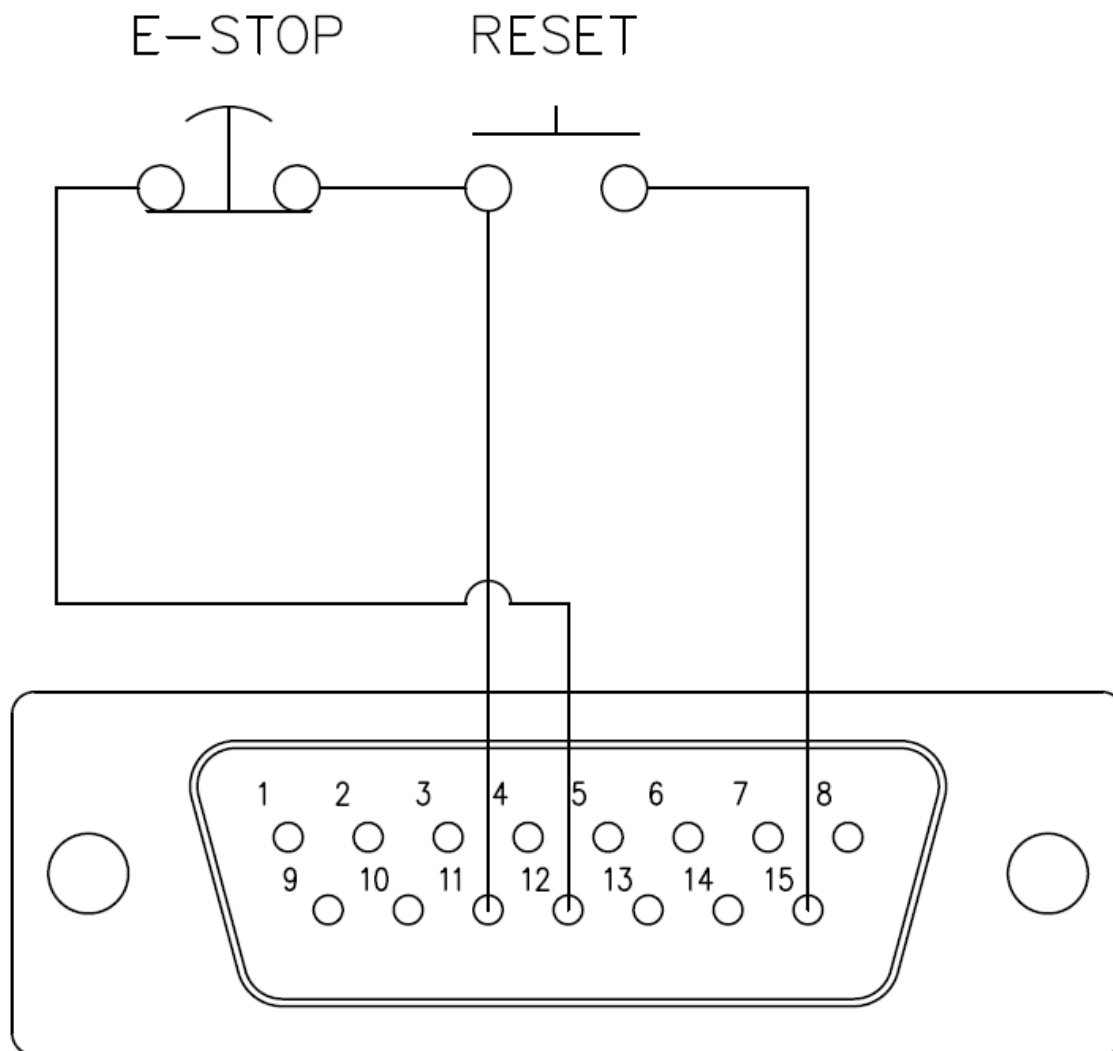



## SECTION 4

# CLEANING & MAINTENANCE

Troubleshooting	4-01
Fault Codes	4-02
Replacing the Power Fuse	4-03

## TROUBLESHOOTING GUIDE

If the system malfunctions, it is necessary to determine where the problem exists in a normal sequence of operation. The procedure of the unit is outlined in the left hand column of the table below to provide a systematic approach to troubleshooting.

<b>Problem</b>	<b>Possible Cause</b>	<b>Corrective Action</b>
Unit will not turn on.	A. Blown Main Fuse	Check main power fuse and replace if necessary as shown on page. Check printer fuse
Tamp will not operate.	A. Cable B. No tamp duration C. Sticky cylinder	Check connection Reference to page 2-11 Consult factory
Unit will not print or tamp	A. Unit off line B. Incorrect label configuration C. No label format downloaded D. Wrong interface selected E. Interface cable F. Error on printer	Check printer cover limit switch Check software Check software Check mode 3 or dip switches Check connection Check printer manual
Take-up unit does not turn.	A. Motor not running B. Friction plate failure in clutch C. Mechanical failure in clutch	Consult Factory Consult Factory Consult Factory
Waste web tension to loose.	A. Clutch tension too low.	Adjust clutch as shown on page 2-10.
Waste web breaks or printing drifts on labels	A. Clutch adjusted to tight. B. Machine Webbed wrong. C. Low quality webbing. D. Friction plate failure in clutch. E. Mechanical failure in clutch.	Adjust clutch as shown on page 2-10. Re-web system as shown on page2-2. Consult label mfg. Consult factory. Consult factory.

## FAULT MESSAGES

DISPLAYED FAULT	FAULT	CORRECTIVE ACTION
Memory Checksum	Data lost in serial EEPROM	Consult factory or service provider
Print Time Out	Printer failed to print or Control failed to receive a "End Print Signal"	<ul style="list-style-type: none"> <li>A. Printer Off Line</li> <li>B. No Label Formats Loaded</li> <li>C. Check Printer Interface Cable</li> <li>D. Printer mode incorrect</li> </ul>
Tamp Down FLT	Head up limit switch failed to switch during the tamp cycle. Cylinder did not move off of reed switch.	<ul style="list-style-type: none"> <li>A. Tamp Cylinder Is Not Up</li> <li>B. Miss Adjusted Reed Switch</li> <li>C. Faulty Reed Switch</li> <li>D. Tamp duration too small</li> <li>E. Check programming of Tamp switch</li> </ul> <p>NOTE: Light on reed switch should be on when cylinder is up</p>
Head Down	Head up limit switch failed to switch during the tamp cycle. Cylinder did not return up.	<ul style="list-style-type: none"> <li>A. Tamp Cylinder Is Not Up</li> <li>B. Miss Adjusted Reed Switch</li> <li>C. Faulty Reed Switch</li> <li>D. Tamp duration too small</li> <li>E. Check programming of Tamp switch</li> </ul> <p>NOTE: Light on reed switch should be on when cylinder is up</p>
Ribbon Out	Printer is out of ribbon	Check printer for ribbon
Low Ribbon	Printer is low on ribbon	Check printer for ribbon
Label Out	Printer is out of ribbon	Check printer for label stock

## REPLACING THE MAIN POWER FUSE

The circuitry is protected from a current overload by GMA 10A a fast blow fuse. Should the applier fail to operate, the condition of this fuse should be checked. If the fuse is open, the cause of the overload condition must be determined and corrected prior to replacing the fuse. NEVER replace the fuse with one of a greater AMP rating. The specified rating has been selected to prevent damage and/or injury.

### ACTIONS TO REPLACE THE MAIN FUSE

1. Set the main power switch to the OFF position.
2. Disconnect the AC power cable from the rear of the console.
3. Locate the fuse holder / power cord assembly.
4. Gently press down the fuse holder cover while pulling away from the console.
5. Replace with the spare fuse provided in the holder.

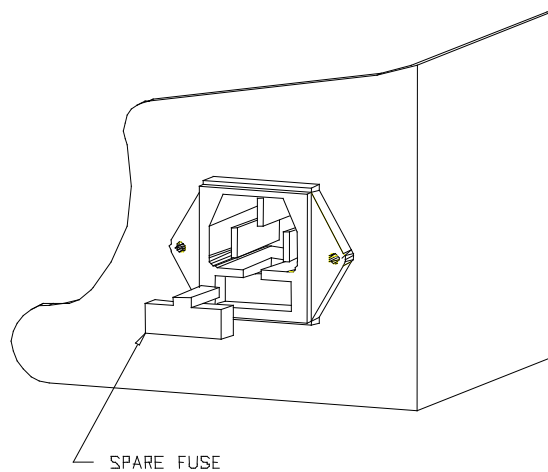

# LM3612

## PRINT & APPLY

# OPERATIONS MANUAL

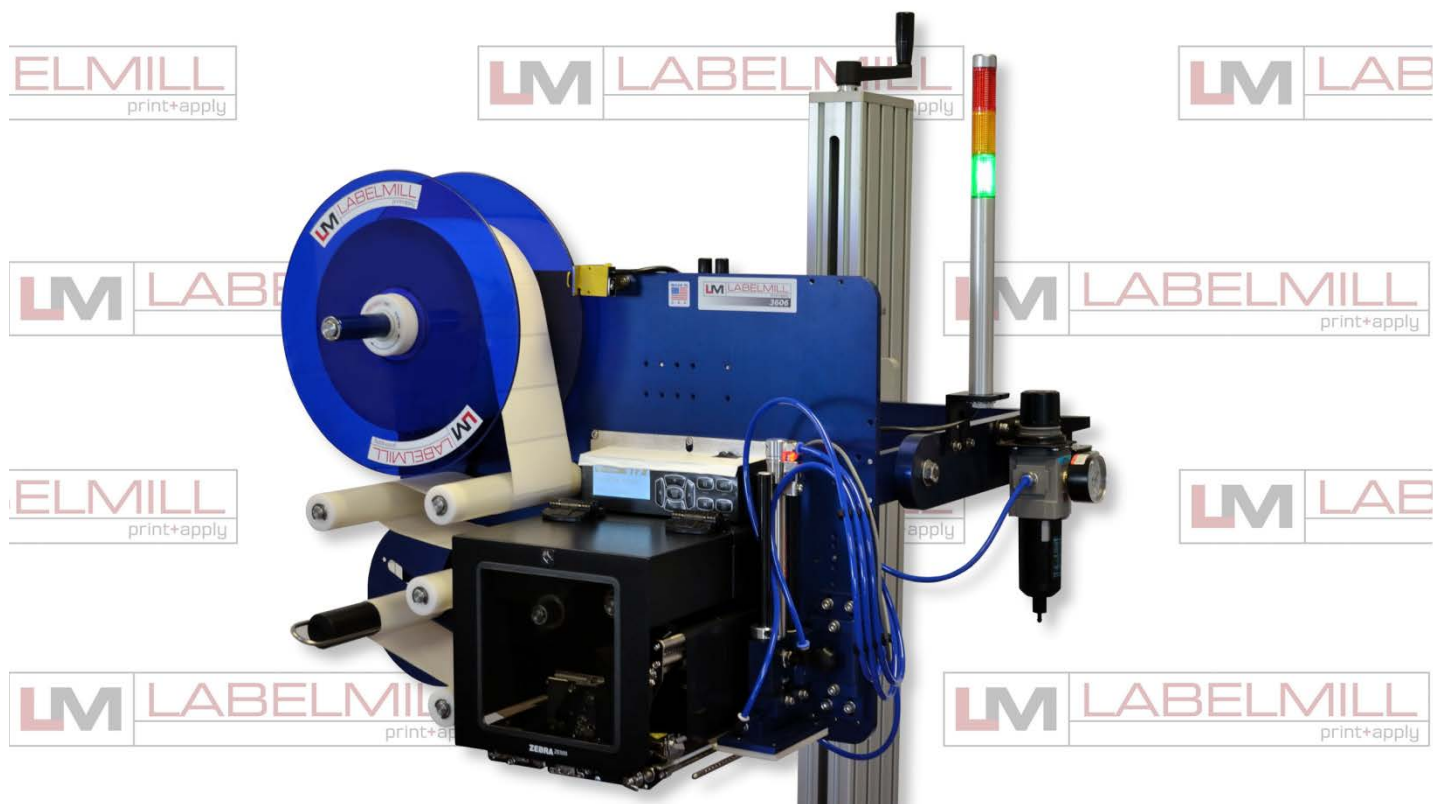

## Copyright and Trademarks

Copyright ©2021  
All rights reserved. All trademarks and brand names  
are the property of their respective owners.

LabelMill  
2416 Jackson St.  
Savanna, IL 61074

Phone: (800) 273-4707; Fax (815) 273-7074  
[www.labelmill.com](http://www.labelmill.com)  
[info@labelmill.com](mailto:info@labelmill.com)



(844) 477-4911 | [www.ipsiscan.com](http://www.ipsiscan.com)