

TTP-225 Series

■ Thermal Transfer ■ Direct Thermal
Desktop Barcode Printers



Series Lists:

TTP-225 / TTP-323

User Manual

Copyright information

©2021 TSC Auto ID Technology Co., Ltd.

The copyright in this manual, the software and firmware in the printer described are owned by TSC Auto ID Technology Co., Ltd. All rights reserved.

CG Triumvirate is a trademark of Agfa Corporation. CG Triumvirate Bold Condensed font is under license from the Monotype Corporation. Windows is a registered trademark of Microsoft Corporation.

All other trademarks are the property of their respective owners. Information in this document is subject to change without notice and does not represent a commitment on the part of TSC Auto ID Technology Co. No part of this manual may be reproduced or transmitted in any form or by any means, for any purpose other than the purchaser's personal use, without the expressed written permission of TSC Auto ID Technology Co.



Table of Contents

1. Introduction	1
2. Operation Overview.....	2
2.1 Unpacking and Inspection.....	2
2.2 Printer Overview	3
2.2.1 Front View.....	3
2.2.2 Interior View	4
2.2.3 Rear View.....	5
3. Setup.....	6
3.1 Setting up the Printer	6
3.2 Loading the Ribbon.....	7
3.3 Loading the Media	8
3.4 Loading the Media in Peel-off Mode (Option).....	9
3.5 Loading the Media in Cutter Mode (Option).....	10
3.6 Loading Thick Media (Thickness is 0.19 mm)	11
3.7 Install MicroSD Memory Card	12
3.8 Using the PC USB Keyboard with Printer USB Host Interface (Factory option).....	13
4. LED and Button Functions.....	14
4.1 LED Indicator	14

4.2 Regular Button Function	14
4.3 Power-on Utilities	15
5. TSC Console	16
5.1 Start TSC Console	16
5.2 Setup Ethernet Interface	18
5.3 Printer Function	20
5.4 Setting Post-Print Action	21
6. Troubleshooting	22
7. Maintenance	25
8. Agency Compliance and Approvals	27
9. Revision History	30



1. Introduction

Thank you very much for purchasing TSC bar code printer.

TTP-225 Series provides direct thermal printing at user selectable speed of: 2.0, 3.0, 4.0 or 5.0 ips. It accepts roll feed, die-cut, and fan-fold media with gap or black mark. All common bar codes formats are available. Fonts and bar codes can be printed in 4 directions, 8 different alphanumeric bitmap fonts and built-in scalable font capability. You will enjoy trouble free, high throughput for printing labels with this printer.

This document provides an easy reference for operating the TTP-225 series printer. For system integration, the TSPL/TSPL2 printer programming manual or SDKs can be found on TSC website at: <https://www.tscprinters.com>.

2. Operation Overview

2.1 Unpacking and Inspection

This printer has been specially packaged to withstand damage during shipping. Please carefully inspect the packaging and printer upon receiving the bar code printer. Please retain the packaging materials in case you need to reship the printer.

Unpacking the printer, the following items are included in the carton.

- One printer unit
- One quick installation guide
- One power cord
- One auto switching power supply
- One USB interface cable
- One paper core

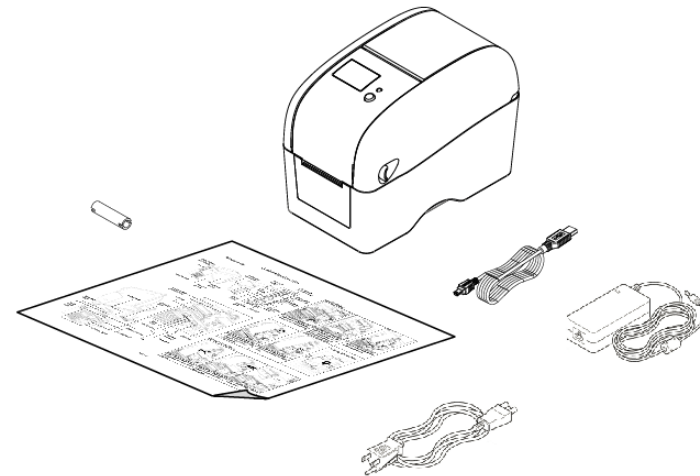

If any parts are missing, please contact the Customer Service Department of your purchased reseller or distributor.

2.2 Printer Overview

2.2.1 Front View



1. LCD display (Factory option)
2. LED indicator
3. Feed button
4. Paper exit chute
5. Media view window
6. Top cover open lever

2.2.2 Interior View

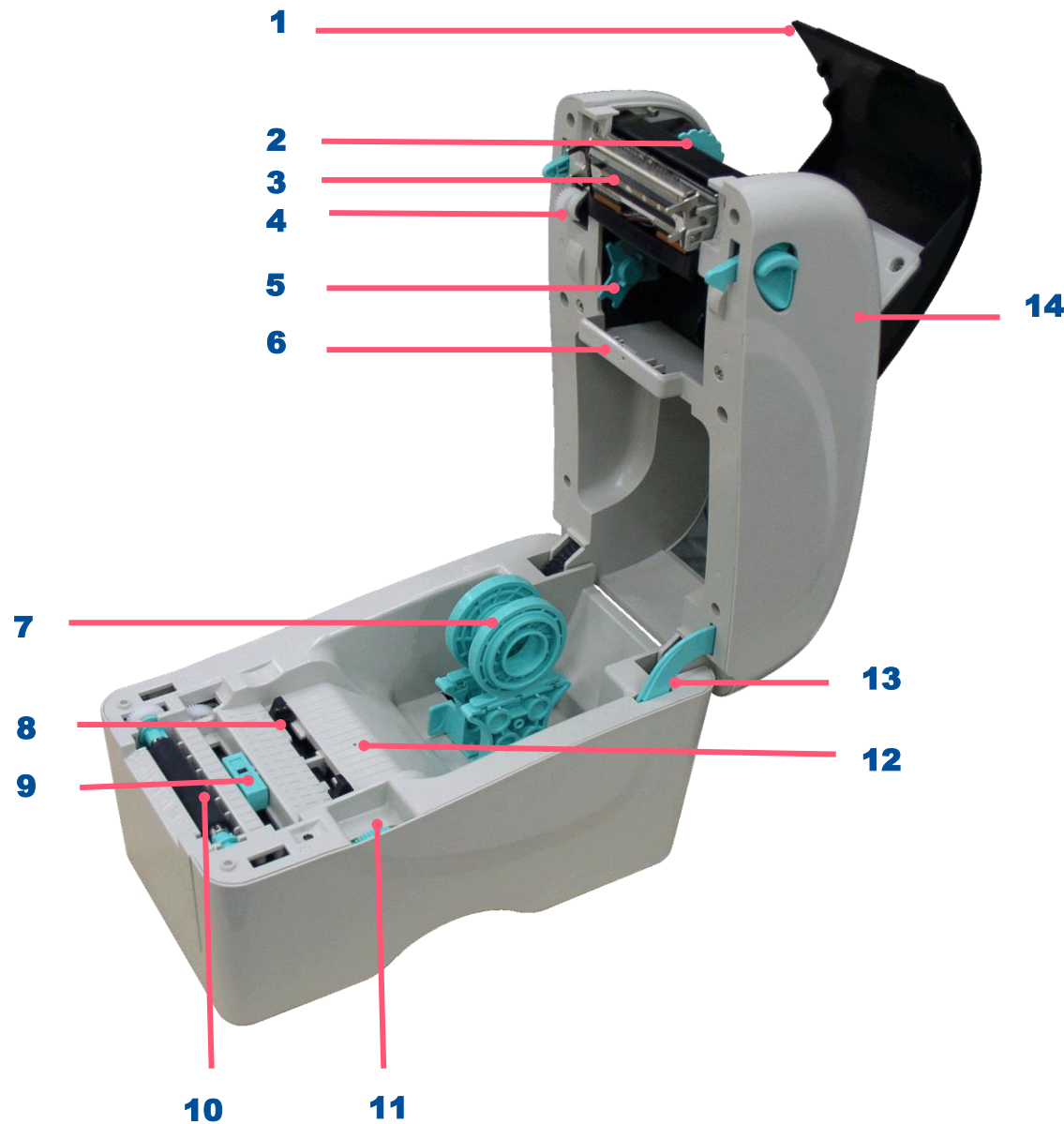

- 1. Ribbon access cover
- 2. Ribbon rewind hub
- 3. Ribbon rewind gear
- 4. Print head
- 5. Ribbon supply hub
- 6. Gap sensor (receiver)
- 7. Media holders
- 8. Media guide
- 9. Black mark sensor
- 10. Platen roller
- 11. Media guide adjuster knob
- 12. Gap sensor (transmitter)
- 13. Top cover support
- 14. Top cover

2.2.3 Rear View

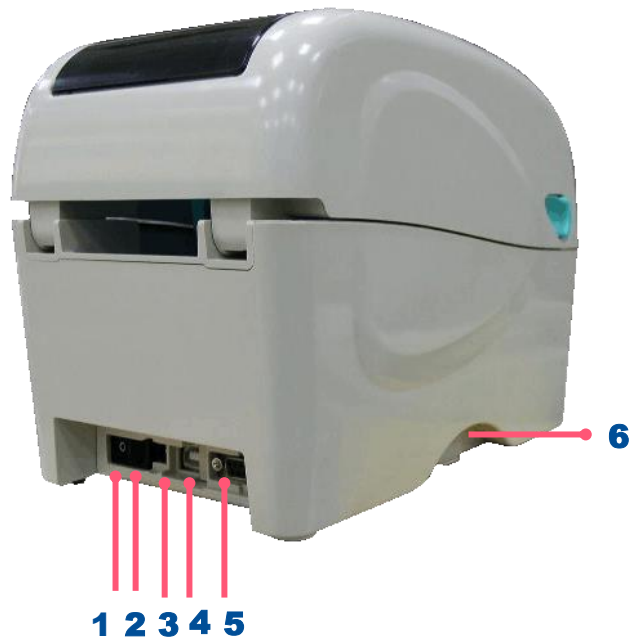

1. Power switch
2. Power jack socket
3. USB interface
4. USB host (Factory option)
5. RS-232C interface / Ethernet interface (Option)
6. SD card socket

Note: The interface picture here is for reference only. Please refer to the product specification for the interface availability.

3. Setup

3.1 Setting up the Printer

1. Place the printer on flat surface.
 2. Make sure the printer is power off.
 3. Connect the printer to the computer with the provided USB cable.
 4. Plug in the power cord.
- ◆ **Note: Please switch OFF the printer before plugging in the power cord to printer power jack.**

3.2 Loading the Ribbon

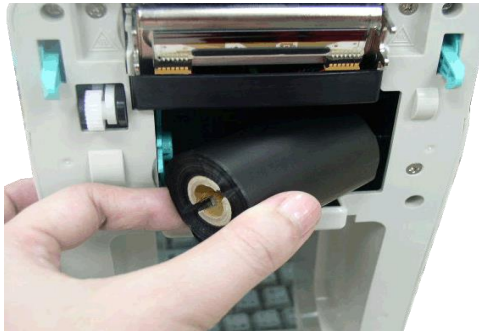

1. Open the printer's top cover, insert the ribbon right side onto the supply hub then align to the left.



2. Open the ribbon access cover.



3. Insert the paper core right side onto the rewind hub. Align the notches on the left side and mount onto the spokes.

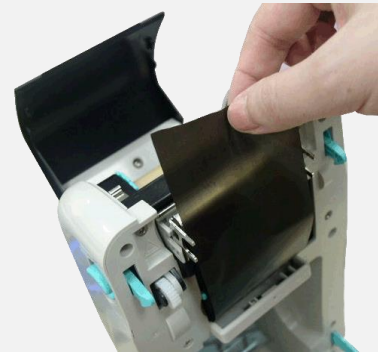

4. Pull the leading ribbon to pass the print head.

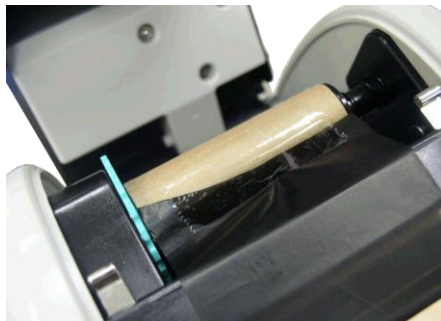

5. Stick the ribbon onto the ribbon rewind paper core.

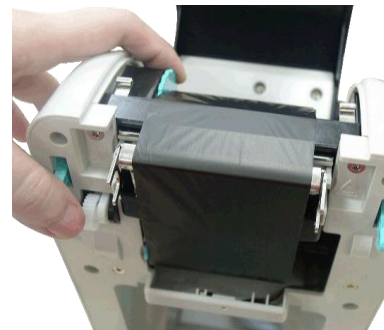

6. Turn the ribbon rewind gear until the ribbon plastic leader is thoroughly wound and the black section of the ribbon covers the print head. Close the ribbon access cover and the top cover.

3.3 Loading the Media



1. Open the printer top cover by pulling the tabs.

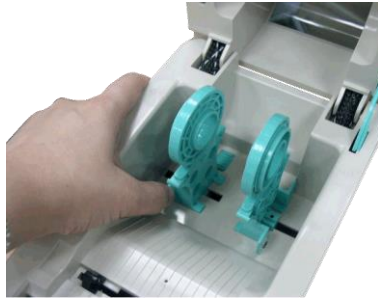

2. Separate the media holders to the label roll width.

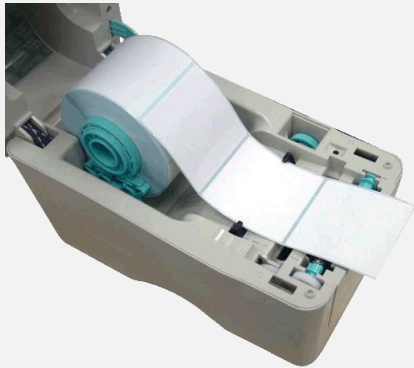

3. Place the roll between the holders then place the paper.(printing side face up)

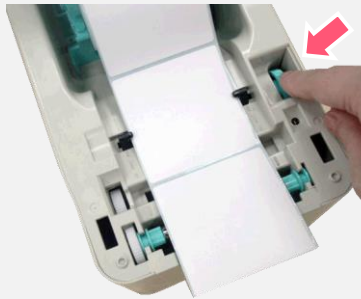

4. Move the media guides to fit the label width by turning the media guide adjuster knob.



5. Hold the top cover and press the top cover support to disengage the top cover support with lower inner cover.



6. Gently close the top cover. Make sure the cover latches securely.

3.4 Loading the Media in Peel-off Mode (Option)



1. Install the media then open the top cover and peel-off panel after calibrating the sensor.

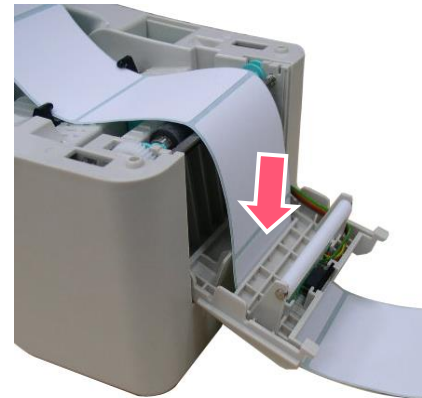

2. Lead the media through the backing paper opening slot beneath the peel-off roller.

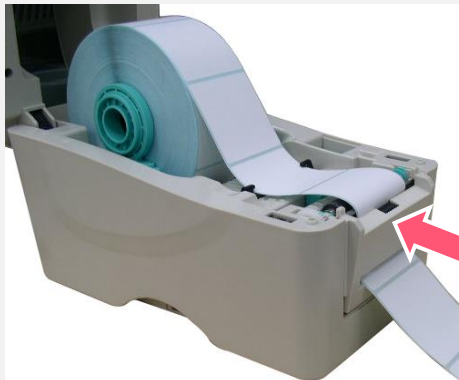

3. Push the peel-off panel back to the printer.



4. Close the top cover gently, and press the FEED button to test.

Note: Please calibrate the gap/black mark sensor when changing media.

3.5 Loading the Media in Cutter Mode (Option)

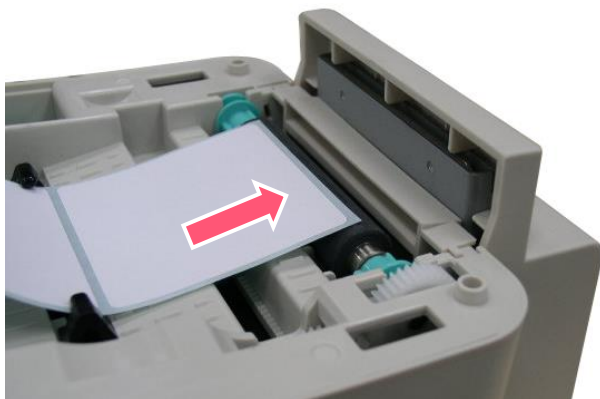

1. Load the media and lead the media through the cutter paper opening.

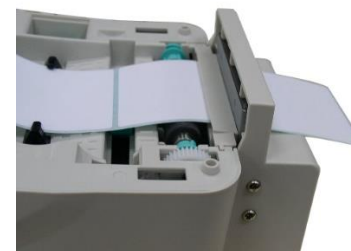

2. Close the top cover gently.



3.6 Loading Thick Media (Thickness is 0.19 mm)

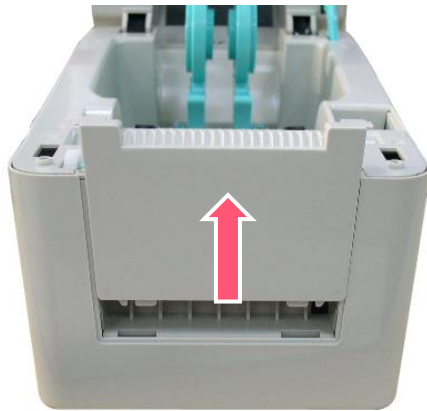

1. Open the printer top cover and remove the lower front cover.

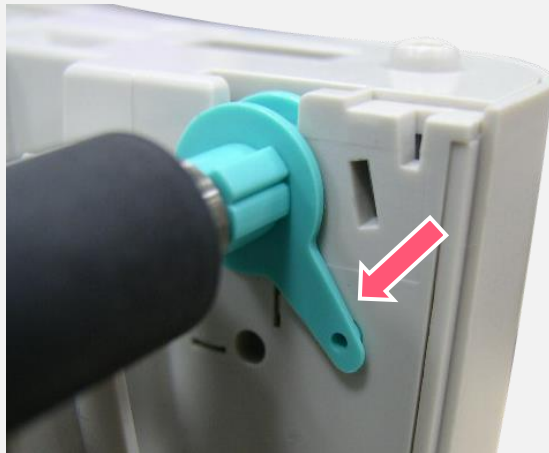

2. Disengage the platen holder tabs from the lower inner cover by pulling out the right side and left side tabs. Alter the both side tabs into the 90 degree position for thick label.

The tab here is for regular label.

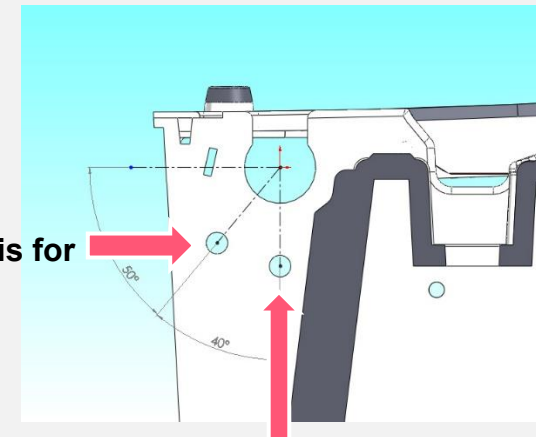

The tab here is for thick label.
(Thickness is 0.19 mm)

3.7 Install MicroSD Memory Card



1. Open the SD memory card cover.



2. Insert the MicroSD card into the socket.

3.8 Using the PC USB Keyboard with Printer USB Host Interface (Factory option)

1. Turn off the printer power.
2. Plug in the PC USB keyboard into printer USB host interface.
3. Turn on the printer power.
4. After pressing the **F1** key of the keyboard, the printer LCD will display as following.

```
File List
> DRAM
  FLASH
```

5. Use up **↑** or down **↓** key of the keyboard to move “>” cursor to select either DRAM, FLASH or CARD that you previously saved file in and press **Enter** key of the keyboard to list files.
6. Select the file and press Enter key to run the .BAS program.

```
FLASH List
> TEST1.BAS
  TEST2.BAS
```

7. Then, you can enter the data from keyboard for stand-alone application.

Press PC keyboard **F1** key to start this function.

Press up **↑** or down **↓** key to move the cursor to the option.

Press **Esc** key to return to previous menu.



Press **Enter** key to enter/run cursor located option.

Press **Ctrl + C** keys to reset the printer and enter “Ready”.

4. LED and Button Functions

This printer has one button and one three-color LED indicator. By indicating the LED with different color and pressing the button, printer can feed labels, pause the printing job, select and calibrate the media sensor, print printer self-test report, reset printer to defaults (initialization). Please refer to the button operation below for different functions.

4.1 LED Indicator

Color	Meaning
 (Green)	Solid: Power is on and ready to be used. Flash : System is downloading data or printer is paused.
 (Amber)	System is clearing data.
 (Red)	Solid - Printer head open, cutter error. Flash - Printing error, such as paper empty, paper jam, ribbon empty, or memory error etc.

4.2 Regular Button Function

1. Feed labels

When the printer is ready, press the button to feed one label to the beginning of next label.

2. Pause the printing job

When the printer is printing, press the button to pause a printing job. When the printer is paused, the LED will be green blinking. Press the button again to continue the printing job.

4.3 Power-on Utilities

Power-on Utilities provides the basic functions and can be activated by below procedures:

Turn off the power > **Hold** the Feed button > **Open** the power > **Release** the Feed button depending on the color of the LED.

Sequences of the settings:

LED Colors Functions	Amber	Red (5 blinks)	Amber (5 blinks)	Green (5 blinks)	Green / Amber (5 blinks)	Red / Amber (5 blinks)	Solid green
1. Sensor Calibration (Gap / black mark sensor)		Release					
2. Self-Test (And enter dump mode)			Release				
3. Factory Default				Release			
4. Bline Calibration					Release		
5. Gap Calibration						Release	
6. READY (Skip AUTO.BAS)							Release

5. TSC Console

TSC Console is a management tool combining the Printer Management, Diagnostic Tool, CommTool and Printer Webpage settings, which enables you to adjust printer's settings/status; change printers' settings; download graphics, deploy fonts, graphics, label templates or upgrade the firmware to the group of printers, and send additional commands to printers at the same time.

※ **Printer firmware version before A2.12 will only use 9100 Port as command port; Printer firmware after A2.12 will use 6101 Port as command port.**

5.1 Start TSC Console

1. Double click TSC Console icon to start the software.

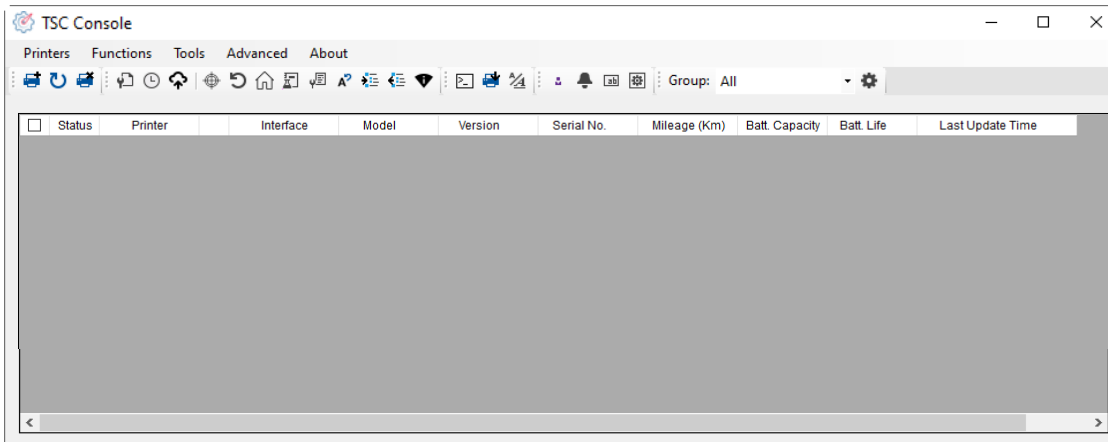

2. Manually add the devices by clicking **Printer > Add Printers**.

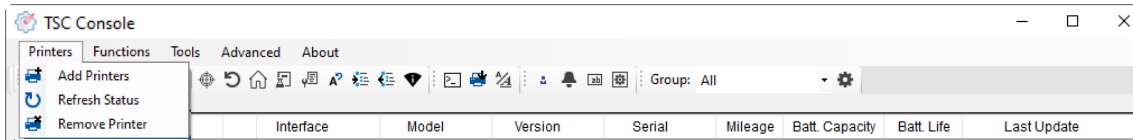

3. Select the current interface of the printer.

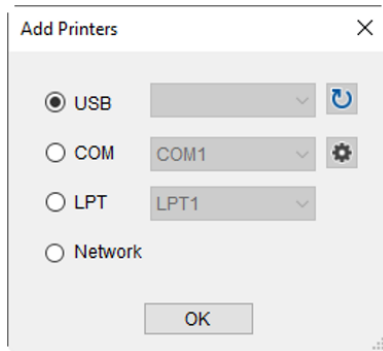

4. The printer will be added to **TSC Console**'s interface.

5. Select the printer and set the settings.

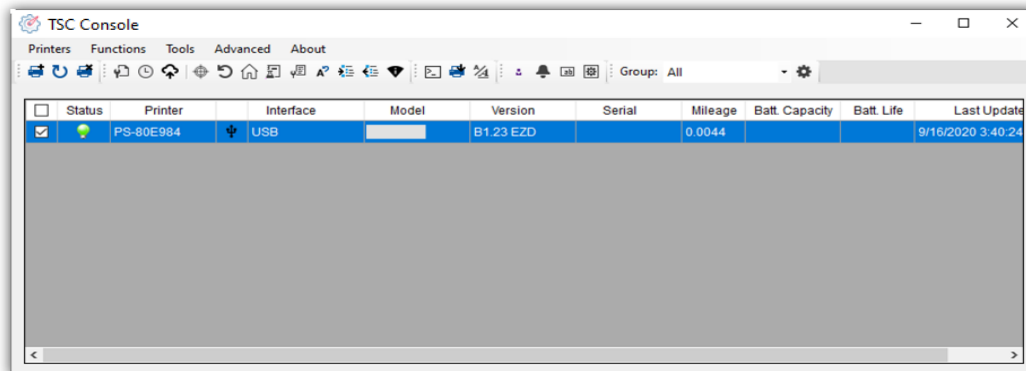

For more information, please refer to **TSC Console User Manual**.

5.2 Setup Ethernet Interface

1. Use **USB** or **COM** to establish the interface on **TSC Console**.

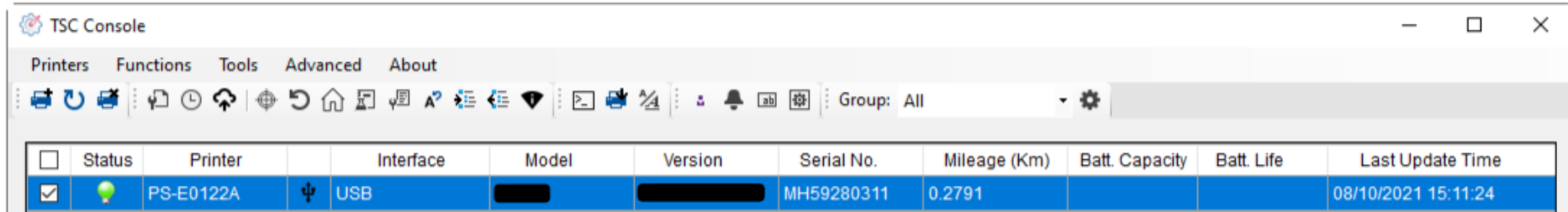

The screenshot shows the TSC Console application window. The title bar reads "TSC Console". Below the title bar is a menu bar with "Printers", "Functions", "Tools", "Advanced", and "About". A toolbar contains various icons for printer management. Below the toolbar is a table with the following columns: Status, Printer, Interface, Model, Version, Serial No., Mileage (Km), Batt. Capacity, Batt. Life, and Last Update Time. The table contains one row of data:

Status	Printer	Interface	Model	Version	Serial No.	Mileage (Km)	Batt. Capacity	Batt. Life	Last Update Time
<input checked="" type="checkbox"/>	PS-E0122A	USB			MH59280311	0.2791			08/10/2021 15:11:24

2. Double click to enter the **Printer Configuration Page** > Click **Ethernet** tab > Check the **IP Address**.

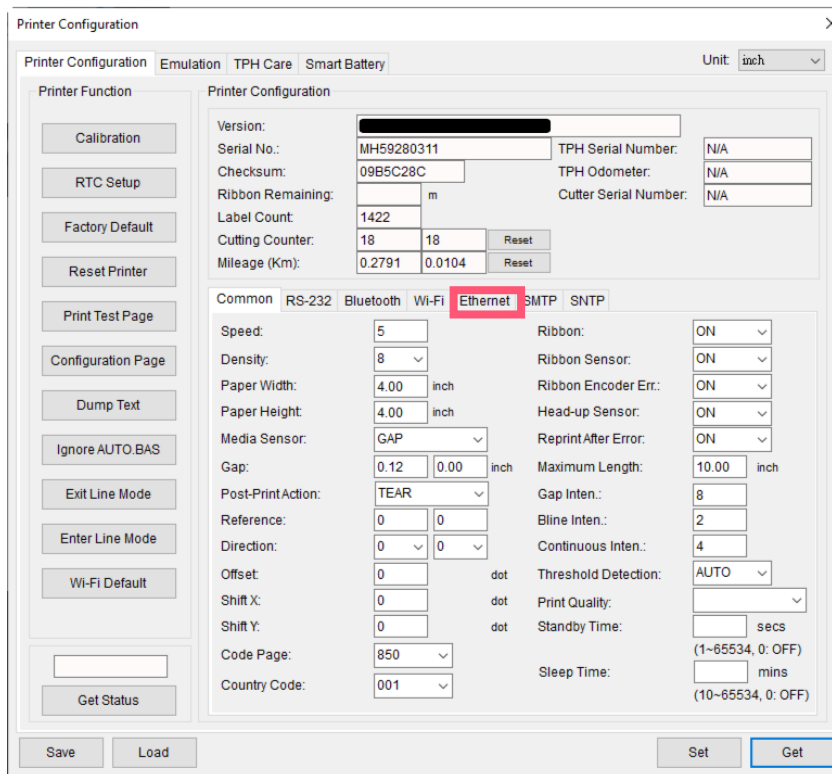

The screenshot shows the "Printer Configuration" dialog box. The "Printer Configuration" tab is selected. The "Ethernet" sub-tab is highlighted with a red box. The "Ethernet" sub-tab contains the following settings:

Common	RS-232	Bluetooth	Wi-Fi	Ethernet	SMTP	SNTP
Speed: 5				Ribbon: ON		
Density: 8				Ribbon Sensor: ON		
Paper Width: 4.00 inch				Ribbon Encoder Err.: ON		
Paper Height: 4.00 inch				Head-up Sensor: ON		
Media Sensor: GAP				Reprint After Error: ON		
Gap: 0.12 0.00 inch				Maximum Length: 10.00 inch		
Post-Print Action: TEAR				Gap Inten.: 8		
Reference: 0				Blind Inten.: 2		
Direction: 0 0				Continuous Inten.: 4		
Offset: 0 dot				Threshold Detection: AUTO		
Shift X: 0 dot				Print Quality: [dropdown]		
Shift Y: 0 dot				Standby Time: [input] secs		
Code Page: 850				(1-65534, 0: OFF)		
Country Code: 001				Sleep Time: [input] mins		
				(10-65534, 0: OFF)		

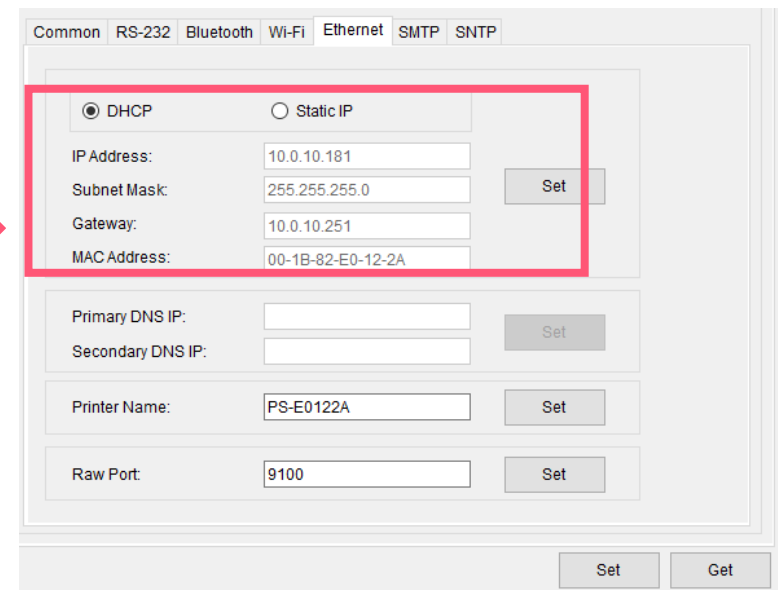

The screenshot shows the "Ethernet" configuration panel. The "DHCP" radio button is selected, and the "Static IP" radio button is unselected. The "IP Address" field is highlighted with a red box. The "IP Address" field contains the value "10.0.10.181". The "Subnet Mask" field contains the value "255.255.255.0". The "Gateway" field contains the value "10.0.10.251". The "MAC Address" field contains the value "00-1B-82-E0-12-2A". The "Set" button is visible next to the "IP Address" field.

- Return to **TSC Console** main page > Click **Add Printer** on the top left of the window.

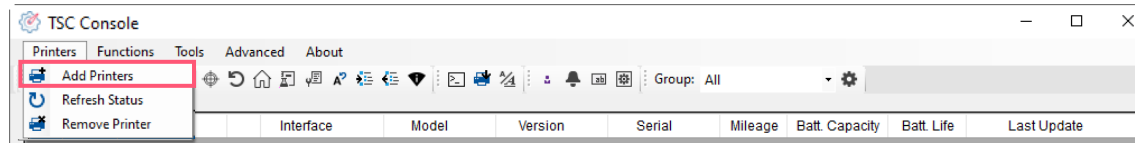

- Choose **Network** > Key in the **IP Address** > Click **Discover** to establish the Ethernet interface.

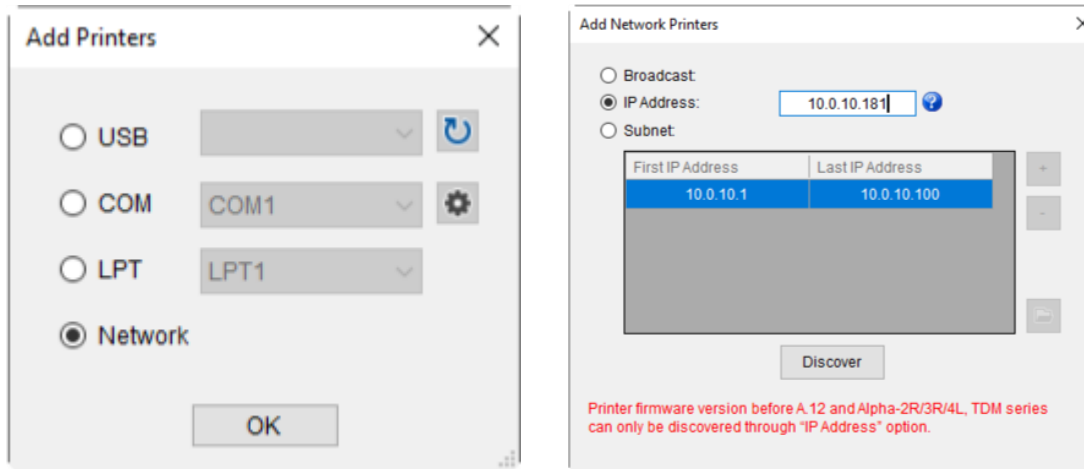

- The notification will pop up > Click **OK** to close the window > The Ethernet interface will be shown on **TSC Console**.

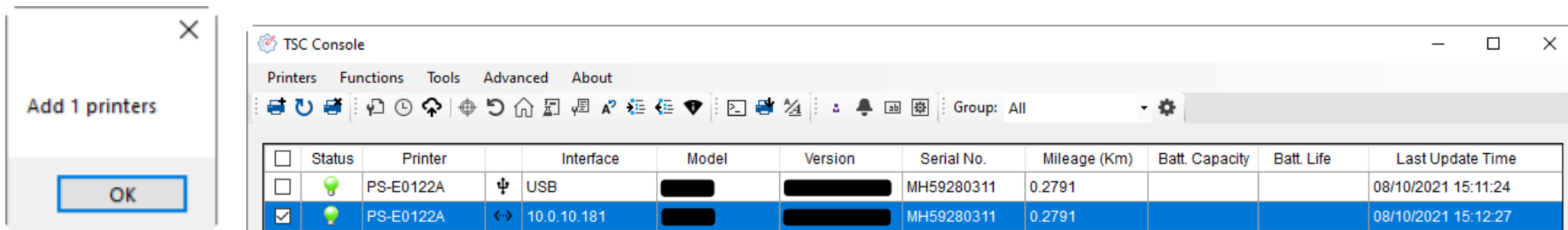

5.3 Printer Function

Printer Function could be found in **Printer Configuration**. “Printer Function” will be shown on the left side of the window.



Functions	Description
Calibrate Sensor	Detect media types and the size of the label
RTC Setup	Synchronize printer with Real Time Clock on PC
Factory Default	Initialize the printer to default settings
Reset Printer	Reboot printer
Print Test Page	Print test page according to the specified label size and sensor type.
Configuration Page	Print printer configurations
Dump Text	Activate the printer to dump mode
Ignore AUTO.BAS	Ignore AUTO.BAS file when printer boot up.
Exit Line Mode	Exit the line mode to page mode
Enter Line Mode	Leave page mode and enter line mode
Reset WiFi	Restore the WiFi settings to defaults.

5.4 Setting Post-Print Action

When the printer is equipped with other option kits, ex: cutter, peeler, rewinder, please select the mode after finishing the calibration.

Follow below procedure to set the post action for the printing:

Refer Ch. 5.1 to Connect the printer with TSC Console > Double click the printer > The Printer Configuration Page will pop up > Click Get to load information > Go to Common Tab > Find Post-Print Action > Select the mode depends on users' application > Click Set.

Printer Configuration

Printer Configuration Emulation TPH Care Smart Battery Unit: mm

Printer Function

- Calibration
- RTC Setup
- Factory Default
- Reset Printer
- Print Test Page
- Configuration Page
- Dump Text
- Ignore AUTO.BAS
- Exit Line Mode
- Enter Line Mode
- Wi-Fi Default
- Get Status

Printer Configuration

Version: []
Serial No.: [] TPH Serial Number: N/A
Checksum: 1344B9B1 TPH Odometer: N/A
Ribbon Remaining: [] % Cutter Serial Number: N/A
Label Count: 553
Cutting Counter: 0 0 Reset
Mileage (Km): 0.0913 0.0913 Reset

Common RS-232 Bluetooth Wi-Fi Ethernet SMTP SNTP

Speed: 3 Ribbon: OFF
Density: 8 Ribbon Sensor: OFF
Paper Width: 104.00 mm Ribbon Encoder Err.: OFF
Paper Height: 74.05 mm Head-up Sensor: ON
Media Sensor: Black Mark Reprint After Error: ON
Gap: 1.99 0.00 mm Maximum Length: 152.25 mm
Post-Print Action: [] Gap Inten.: 7
Reference: OFF Bline Inten.: 7
Direction: TEAR Continuous Inten.: 4
Offset: PEEL Threshold Detection: AUTO
Shift X: CUTTER Print Quality: STANDARD
Shift Y: REWIND Standby Time: 120 secs
Code Page: 850 Sleep Time: 0 mins
Country Code: 001 (1~65534, 0: OFF)
(10~65534, 0: OFF)

Save Load

Set Get

6. Troubleshooting

The following guide lists the most common problems that may be encountered when operating this bar code printer. If the printer still does not function after all suggested solutions have been invoked, please contact the Customer Service Department of your purchased reseller or distributor for assistance.

LED Status

This section lists the common problems that according to the LED status and other problems you may encounter when operating the printer. Also, it provides solutions.

LED Status / Color	Printer Status	Possible Cause	Recovery Procedure
OFF	No response	No power	<ul style="list-style-type: none"> * Turn on the power switch. * Check if the green LED is lit on power supply. If it is not lit on, power supply is broken. * Check both power connections from the power cord to the power supply and from the power supply to the printer power jack if they are connected securely.
Solid Green	ON	The printer is ready to use	<ul style="list-style-type: none"> * No action necessary.
Green with blinking	Pause	The printer is paused	<ul style="list-style-type: none"> * Press the FEED button to resume for printing.
Red with blinking	Error	The out of label or the printer setting is not correct	<ol style="list-style-type: none"> 1. Out of label * Load a roll of label and follow the instructions in loading the media then press the FEED button to resume for printing. 2. Printer setting is not correct * Initialize the printer.

Print Problem

Problem	Possible Cause	Recovery Procedure
Not Printing	Check if interface cable is well connected to the interface connector.	Re-connect cable to interface.
	The serial port cable pin configuration is not pin to pin connected.	Please replace the cable with pin to pin connected.
	The serial port setting is not consistent between host and printer.	Please reset the serial port setting.
	The port specified in the Windows driver is not correct.	Select the correct printer port in the driver.
	The Ethernet IP, subnet mask, gateway is not configured properly.	Configure the IP, subnet mask and gateway.
No print on the label	Label loaded not correctly.	Follow the instructions in loading the media.
Continuous feeding labels	The printer setting may go wrong.	Please do the initialization and gap/black mark calibration.
Paper Jam	Gap/black mark sensor sensitivity is not set properly (sensor sensitivity is not enough)	Calibrate the gap/black mark sensor.
	Make sure label size is set properly.	Set label size exactly as installed paper in the labeling software or program.
	Labels may be stuck inside the printer mechanism near the sensor area.	Remove the stuck label.
Poor Print Quality	Top cover is not closed properly.	Close the top cover completely and make sure the right side and left side levers are latched properly.
	Wrong power supply is connected with printer.	Check if 24V DC output is supplied by the power supply.
	Check if supply is loaded correctly.	Reload the supply.
	Check if dust or adhesives are accumulated on the print head.	Clean the print head.
	Check if print density is set properly. Check print head test pattern if head element is damaged.	Adjust the print density and print speed. Run printer self-test and check the print head test pattern if there is dot missing in the pattern.

LCD display (Option for TDP-225/324 model)

This section lists the LCD display messages that you may encounter when operating the printer. Also, it provides solutions.

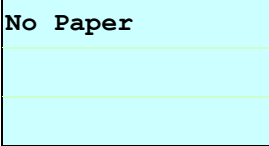
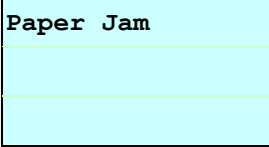
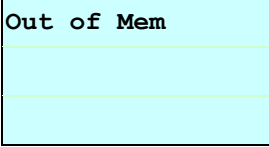
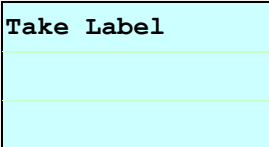
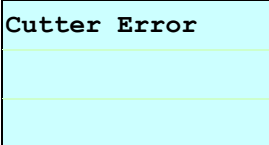
Messages	Possible Cause	Recovery Procedure
	<ul style="list-style-type: none"> * The printer top cover is open. 	<ul style="list-style-type: none"> * Please close the top cover.
	<ul style="list-style-type: none"> * Running out of label. * The label is installed incorrectly. * Gap/black mark sensor is not calibrated. 	<ul style="list-style-type: none"> * Supply a new label roll. * Please refer to the steps in user's manual to reinstall the label roll. * Calibrate the gap/black mark sensor.
	<ul style="list-style-type: none"> * Gap/black mark sensor is not set properly. * Make sure label size is set properly. * Labels may be stuck inside the printer mechanism. 	<ul style="list-style-type: none"> * Calibrate the gap/black mark sensor. * Set label size correctly.
	<ul style="list-style-type: none"> * The space of FLASH/DRAM or MicroSD card is full. 	<ul style="list-style-type: none"> * Delete unused files in the FLASH/DRAM or MicroSD card.
	<ul style="list-style-type: none"> * Peel function is enabled. Waiting user to take label away to print the next label. 	<ul style="list-style-type: none"> * Please take the label away to print the next label if peeler module is installed. * If peeler module is installed and label is been taken away, but the message remains. Please check if the peeler module connector is connected to main board properly. * If peeler module is not installed, please disable the peeler function.
	<ul style="list-style-type: none"> * Cutter jam. * There is no cutter installed on the printer. * Cutter or cutter driver circuit board is damaged. 	<ul style="list-style-type: none"> * Remove the jammed label. * Make sure the media thickness is equal or less than 0.19mm. * Replace the cutter or cutter driver circuit board.

7. Maintenance

This session presents the clean tools and methods to maintain the printer.

■ For Cleaning

Depending on the media used, the printer may accumulate residues (media dust, adhesives, etc.) as a by-product of normal printing. To maintain the best printing quality, you should remove these residues by cleaning the printer periodically. Regularly clean the print head and supply sensors once change a new media to keep the printer at the optimized performance and extend printer life.

■ For Disinfecting

Sanitize your printer to protect yourself and others and can help prevent the spread of viruses.

■ Important

- Set the printer power switch to O (Off) prior to performing any cleaning or disinfecting tasks. Leave the power cord connected to keep the printer grounded and to reduce the risk of electrostatic damage.
- Do not wear rings or other metallic objects while cleaning any interior area of the printer.
- Use only the cleaning agents recommended in this document. Use of other agents may damage the printer and void its warranty.
- Do not spray or drip liquid cleaning solutions directly into the printer. Apply the solution on a clean lint-free cloth and then apply the dampened cloth to the printer.
- Do not use canned air in the interior of the printer as it can blow dust and debris onto sensors and other critical components.
- Only use a vacuum cleaner with a nozzle and hose that are conductive and grounded to drain off static build up.
- All reference in these procedures for use of isopropyl alcohol requires that a 99% or greater isopropyl alcohol content be used to reduce the risk of moisture corrosion to the printhead.
- Do not touch printhead by hand. If you touch it carelessly, please use 99% Isopropyl alcohol to clean it.
- Always taking personal precaution when using any cleaning agent.

Cleaning Tools

- Cotton swab
- Lint-free cloth
- Brush with soft non-metallic bristles
- Vacuum cleaner
- 75% Ethanol (for disinfecting)
- 99% Isopropyl alcohol (for printhead and platen roller cleaning)
- Genuine printhead cleaning pen
- Mild detergent (without chlorine)

Cleaning Process:

Printer Part	Method	Interval
Print Head	<ol style="list-style-type: none"> I. Always turn off the printer before cleaning the printhead. II. Allow the printhead to cool for at least one minute. III. Use a cotton swab and 99% Isopropyl Alcohol or genuine print head cleaning pen to clean the print head surface. 	Clean the print head when changing a new label roll.
Platen Roller	<ol style="list-style-type: none"> I. Turn off the printer. II. Rotate the platen roller and wipe it thoroughly with the lint-free 99% Isopropyl Alcohol. 	Clean the platen roller when changing a new label roll
Peel Bar	Use the lint-free cloth with 99% Isopropyl Alcohol to wipe it.	As needed
Sensor	Use brush with soft non-metallic bristles or a vacuum cleaner, to remove paper dust. Clean upper and lower media sensors to ensure reliable Top of Form and Paper Out sensing.	Monthly
Exterior	Clean the exterior surfaces with a clean, lint-free cloth (water-dampened cloth). If necessary, use a mild detergent or desktop cleaning solution then use the 75% Ethanol to wipe it.	As needed
Interior	Clean the interior of the printer by removing any dirt and lint with a vacuum cleaner, as described above, or use a brush with soft non-metallic bristles then use the 75% Ethanol to wipe it.	As needed

8. Agency Compliance and Approvals



EN 55032, Class B
EN 55024
EN 60950-1; EN 61000-3-2; EN 61000-3-3

FCC part 15B, Class B
ICES-003, Class B

This equipment has been tested and found to comply with the limits for a Class B digital device, pursuant to part 15 of the FCC Rules. These limits are designed to provide reasonable protection against harmful interference in a residential installation. This equipment generates, uses and can radiate radio frequency energy and, if not installed and used in accordance with the instructions, may cause harmful interference to radio communications. However, there is no guarantee that interference will not occur in a particular installation. If this equipment does cause harmful interference to radio or television reception, which can be determined by turning the equipment off and on, the user is encouraged to try to correct the interference by one or more of the following measures:



- Reorient or relocate the receiving antenna.
- Increase the separation between the equipment and receiver.
- Connect the equipment into an outlet on a circuit different from that to which the receiver is connected.
- Consult the dealer or an experienced radio/ TV technician for help.

This device complies with Part 15 of the FCC Rules. Operation is subject to the following two conditions: (1) This device may cause harmful interference, and (2) this device must accept any interference received, including interference that may cause undesired operation.

This Class B digital apparatus complies with Canadian ICES-003.

Cet appareil numérique de la classe B est conforme à la norme NMB-003 du Canada.



AS/NZS CISPR 32, Class B



UL 60950-1(2nd Edition)
CSA C22.2 No. 60950-1-07(2nd Edition)



EN 60950-1



GB 4943.1
GB 9254, Class B
GB 17625.1



Energy Star for Imaging Equipment Version 2.0



TP TC 004/2011
TP TC 020/2011



IS 13252(Part 1)/
IEC 60950-1



KN 22
KN 24

Note: There may have certification differences in the series models, please refer to product label for accuracy.

Important safety instructions:

1. Read all of these instructions and keep them for later use.
2. Follow all warnings and instructions on the product.
3. Disconnect the power plug from the AC outlet before cleaning or if fault happened.
Do not use liquid or aerosol cleaners. Using a damp cloth is suitable for cleaning.
4. The mains socket shall be installed near the equipment and easily accessible.
5. The unit must be protected against moisture.

6. Ensure the stability when installing the device, Tipping or dropping could cause damage.
7. Make sure to follow the correct power rating and power type indicated on marking label provided by manufacture.
8. Please refer to user manual for maximum operation ambient temperature.

WARNING:

Hazardous moving parts, keep fingers and other body parts away.

CAUTION:

(For equipment with RTC (CR2032) battery or rechargeable battery pack)

Risk of explosion if battery is replaced by an incorrect type.

Dispose of used batteries according to the Instructions as below.

1. DO NOT throw the battery in fire.
2. DO NOT short circuit the contacts.
3. DO NOT disassemble the battery.
4. DO NOT throw the battery in municipal waste.
5. The symbol of the crossed out wheeled bin indicates that the battery should not be placed in municipal waste.



Caution: The printhead may be hot and could cause severe burns. Allow the printhead to cool.

CAUTION:

Any changes or modifications not expressly approved by the grantee of this device could void the user's authority to operate the equipment.

9. Revision History

Date	Content	Editor
2023/8/10	Modify 2.1 Unpacking and Inspection section	Camille

TSC **PRINTRONIX**[®]
AUTO ID